



Personalizza il tuo **ESSENTIAL**<sup>®</sup>  
 Customize your **by SCRIGNO**

Prodotti *Products*

Accessori *Accessories*

	Essential scorrevole <i>Sliding</i>	Essential Dual	Essential Trial	Essential Pro	Essential scorrevole EI 30 <i>Sliding EI 30</i>	Essential battente EI 30/60 <i>Swing EI 30</i>	Essential battente <i>Swing</i>
Scrigno Slow Glass	•						
Scrigno Slow							
Scrigno Open				•			
Ammortizzatore Trial <i>Absorber Trial</i>			•				
Scrigno Switch	•	•	•	•	•	•	•
Ferramenta per ante in vetro <i>Glass door hardware kit</i>	•	•	•				
Kit Chiusiscrigno	•	•	•	•	•	•	•
Soluzione doccia <i>Shower solution</i>	•						
Porte - Door Comfort	•			•			
Porte - Door Trésor	•			•			•
Porte - Door Acqua	•			•			

Per tutte le possibili combinazioni, si prega sempre di verificare la sezione dedicata agli accessori e le relative schede tecniche allegate.

*For all possible combinations, always consult the section dedicated to accessories and the attached information sheets.*

## Indice / Index

- 1 Controtelai | *Frames*
- 12 Essential Scorrevole | *Essential Sliding*
- 18 Essential Pro
- 20 Essential Scorrevole EI 30 | *Sliding EI 30*
- 22 Essential: soluzione doccia  
*Essential: the shower solution*
- 26 Essential Trial
- 30 Essential Dual
- 32 Essential Battente | *Essential Swing*
- 38 Essential Battente Senza Traverso  
*Essential Swing Without Upper Crosspiece*
- 40 Essential Battente Trapezoidale  
*Essential Swing Trapezoidal Shape*
- 42 Essential Battente EI 30/60 | *Essential Swing EI 30/60*
- 44 Essential Battente Zero | *Essential Swing Zero*
- 48 Essential Little | *Little Zero*
- 52 Essential Little Cartongesso  
*Essential Little Plasterboard*
  
- 54 Porte | *Doors*
- 55 Comfort
- 56 Scorrevole per Essential | *Sliding for Essential*
- 58 Prima scorrevole | *Prima sliding*
- 60 Sound scorrevole | *Sound sliding*
- 63 Trésor
- 64 Scorrevole per Essential | *Sliding for Essential*
- 66 Pure scorrevole | *Pure sliding*
- 68 Linea scorrevole | *Linea sliding*
- 70 Battente per Essential | *Swing for Essential*
- 72 Pure battente | *Pure swing*
- 74 Linea battente | *Linea swing*
  
- 76 Soluzioni vetro | *Glass solutions*
- 78 Anta vetro per Essential  
*Sliding glass doors for Essential*
- 80 Anta per Essential Trial  
*Glass door for Essential Trial*
- 82 Anta per Essential Dual  
*Glass door for Essential Dual*
- 84 Acqua per Essential  
*Door for Acqua*
  
- 86 Accessori e personalizzazioni  
*Accessories and customization options*
- 88 Scrigno Slow Glass
- 89 Ammortizzatore per Essential Trial  
*Absorber for Essential Trial*
- 90 Scrigno Switch
- 91 Scrigno Open per Essential Pro  
*Scrigno Open for Essential Pro*
- 92 Ferramenta per porte in vetro per Essential  
*Glass doors hardware for Essential*
- 93 Kit compensatori | Kit carter  
*Compensation kit | Kit cover*
- 94 Kit chiudiscrigno - Rotonda  
*Kit chiudiscrigno - Round*
- 94 Kit chiudiscrigno - Quadra  
*Kit chiudiscrigno - Square*
- 95 Kit chiudiscrigno - Segno  
*Kit chiudiscrigno - Sign*
- 96 Maniglie per porte scorrevoli  
*Handles for swing doors*
- 96 Kit chiudiscrigno per porte a Battente  
*Kit chiudiscrigno for swing doors*
- 97 Kit chiudiscrigno per porte in vetro  
*Handles for swing doors*
- 98 Maniglie per Essential Trial e Dual  
*Handles for Trial and Dual*
- 99 Maniglie per Acqua  
*Handles for Acqua*
- 99 Serratura libero/occupato per Acqua  
*Bathroom door lock for Acqua*
  
- 100 Dettagli tecnici controtelai | *Technical details frames*
- 102 Essential Scorrevole | *Essential Sliding*
- 106 Essential scorrevole 145 | *Essential Sliding 145*
- 110 Essential Pro
- 114 Essential Scorrevole EI 30 | *Sliding EI 30*
- 118 Essential: soluzione doccia  
*Essential: the shower solution*
- 120 Essential Trial
- 124 Essential Dual
- 126 Essential Battente | *Essential Swing*
- 128 Essential Battente Senza Traverso  
*Essential Swing Without Upper Crosspiece*
- 129 Essential Battente Trapezoidale  
*Essential Swing Trapezoidal Shape*
- 132 Essential Battente EI 30/60 | *Essential Swing EI 30/60*
- 138 Essential Battente Zero | *Essential Swing Zero*
- 140 Essential Little
- 144 Essential Little Zero
- 146 Essential Little Cartongesso  
*Essential Little Plasterboard*
  
- 150 Dettagli tecnici porte | *Technical details doors*
- 152 Comfort
- 160 Trésor
- 187 Soluzioni vetro | *Glass solutions*

# Scrigno, azienda e marchio dell'originale controtelaio per porte scorrevoli

*Scrigno, the company and the  
trademark for original sliding door frames*

La storia di Scrigno ha origine nel 1989, quando l'imprenditore riminese Giuseppe Berardi ebbe una geniale intuizione in grado di trasformare la classica "porta scorrevole" in un prodotto originale e differente rispetto all'offerta del mercato: aggiungere un elemento per creare l'innovativa soluzione a scomparsa.

In 25 anni l'Azienda, grazie all'alta qualità dei propri prodotti e servizi, è riuscita ad occupare una posizione di leadership nella produzione e commercializzazione di controtelai per porte e finestre scorrevoli a scomparsa, e oggi è un solido Gruppo divenuto punto di riferimento a livello mondiale nel proprio settore. Scrigno ha sede a Sant'Ermete, nel comune di Santarcangelo di Romagna (RN); l'azienda occupa 51.000 mq di superficie, di cui 12.000 di stabilimento coperto e 1.200 destinati ad uffici.

Nel 2010 è stato inaugurato il secondo stabilimento produttivo a Savignano sul Rubicone (FC), che occupa una superficie di 18.000 mq.

Da gennaio 2003 è attiva Scrigno France, che si trova nel cuore della Francia, a Montceau Les Mines. Nel 2009, a Barcellona, nasce Scrigno España, mentre a gennaio 2014 ha visto la luce Scrigno SRO a Praga.

*Scrigno's story started out in 1989, when Rimini businessman Giuseppe Berardi came up with the brilliant idea of transforming conventional sliding doors into a product that was quite original and different, unlike anything the market of the time was able to offer, adding a vital element to create an innovative sliding door that disappeared into the wall.*

*Thanks to the absolute quality of its products and services, over the last 25 years Scrigno has managed to conquer a primary position in the production and marketing of frames for sliding disappearing doors and windows, and it has now become a firmly established group that is a point of reference in its sector at a worldwide level.*

*Scrigno is based at Sant'Ermete in Santarcangelo di Romagna (RN), occupying a site of 51,000 sq. metres, of which 12,000 are used for production and 1200 for offices.*

*A second factory was opened in 2010 at Savignano sul Rubicone (FC), with a surface area of 18,000 sq. metres.*

*Scrigno France started operations in January 2013, centrally located at Montceau-les-Mines, followed in 2009 by Scrigno España, based in Barcelona, and in January 2014 by Scrigno SRO in Prague.*



Scrigno, sede di Savignano sul Rubicone  
Factory in Savignano sul Rubicone (FC)



Scrigno France, sede di Montceau-les-Mines  
Factory in Montceau-les-Mines France

# Scrigno porte e soluzioni vetro

## Scrigno doors and glass solutions

È qualità riconoscibile, fatta per durare  
*Means recognizable quality, made to last*



Scrigno S.p.A. è dotata di un Sistema di Gestione per la Qualità certificato a norma UNI EN ISO 9001:2008. Non si tratta unicamente di un adempimento formale dei requisiti della normativa vigente, bensì di un supporto e stimolo ulteriore per il miglioramento continuo della gestione dei processi aziendali, finalizzato all'efficacia delle attività ed alla soddisfazione dei clienti.

La qualità Scrigno è riconoscibile dal MARCHIO ORIGINALE impresso sul controtelaio e sulla guida di scorrimento, visibile anche a prodotto montato.

Il controtelaio Gold è sempre accompagnato da:

- GARANZIA A VITA contro la corrosione passante per l'Aluzinc® e una garanzia di 20 anni sui componenti del controtelaio e del carrello;
- un certificato di autenticità sottoscritto dal fondatore di Scrigno, il signor Giuseppe Berardi.

È semplice controllare il controtelaio e la guida di scorrimento: solo se hanno il marchio originale sono Scrigno.

*Scrigno S.p.A. has a Quality Management System certified to the UNI EN ISO 9001:2008 standard.*

*Certification is more than merely formal compliance with the requisites of the current standard, but provides even further stimuli and support to constantly improve the management of company processes, aimed at enhancing both our work and customer satisfaction.*

*Scrigno is a patented system and its success has led to a whole set of competitors, frequently sold as "System Scrigno" or "Model Scrigno". These are imitations. Therefore Scrigno marks each piece and offers a lifetime anti corrosion warranty to Aluzinc® parts and guarantee of 20 years on the components of the frame and the hangers.*



## Le prove di laboratorio

### Lab tests

La qualità dei prodotti Scrigno è ovviamente certificata dai migliori istituti. Ma per Scrigno il concetto di qualità non significa limitarsi al rispetto di quanto previsto dalla legge: a noi piace andare oltre, cercando di stabilire sempre nuovi standard. Per questo motivo certifichiamo un lungo elenco di prove volontarie, che comprovino che i nostri prodotti sono capaci di garantire ottimi risultati, sia in fatto di funzionamento che di sicurezza attiva e passiva.

La gamma Scrigno ha superato rigidi test di resistenza a urti, a carichi di resistenza, prevede prodotti resistenti al fuoco e privi di emissioni nocive.

Anche tutti gli accessori vengono provati e riprovati per migliaia di cicli, perché la qualità di Scrigno sia un valore duraturo in ogni momento.

*The quality of Scrigno products is of course certified by the best institutions. But for Scrigno the concept of quality is not restricted to compliance with legal provisions: we like to go further and try to set new standards. For this reason we certify a long list of voluntary tests, which prove that our products are able to guarantee excellent results, both in terms of operation and active and passive safety. The Scrigno range has passed stringent resistance-to-impact and resistance-to-load tests. It is fire resistant and free of harmful emissions. All accessories are also tested and retested for thousands of cycles to ensure Scrigno quality is a lasting value at all times.*



# La qualità come principio

## *Quality as a principle*

Fin dal lontano 1989, Scigno ha fatto della qualità un principio fondante, una regola insormontabile che accompagna ogni prodotto e ogni processo aziendale. Un'attività costante e talvolta quotidiana fatta di verifiche, controlli, prove di laboratorio e interne tese a mettere sul mercato soluzioni altamente performanti nel tempo, superando di gran lunga le disposizioni di legge. Ricerca, innovazione e qualità sono il nostro pane quotidiano: i numerosi brevetti rappresentano la nostra migliore certificazione di qualità. L'attività costante prevede oltre 30 controlli sul ciclo produttivo, a partire dall'arrivo della materia prima. Scigno, infatti, sottopone tutti i propri coil di lamiera a test di radioattività perché vogliamo che i nostri prodotti non solo funzionino bene ma siano sicuri per la salute di chi li userà per molti anni.

La qualità di ogni singolo componente è testata ad ogni fornitura, così come vengono imposte prove di conformità ad elevati standard qualitativi a tutti i nostri fornitori. Non a caso la quasi totalità dei componenti utilizzati proviene da produttori rigorosamente Made in Italy e concentrati a breve distanza dai nostri stabilimenti.

*Ever since 1989, Scigno has made quality a founding principle, an insurmountable rule that accompanies every product and every business process.*

*A constant and sometimes daily activity made up of daily checks, controls, laboratory and in-house tests aimed at placing on the market high-performance solutions that far exceed legal requirements.*

*Research, innovation and quality are our daily bread.*

*Our numerous patents represent our best quality certification.*

*Over 30 controls are made on the production cycle, starting from the arrival of raw material. Scigno in fact tests all its metal coils for radioactivity because we want our products not only to work well but to be safe for the health of those who use them for many years.*

*The quality of each individual component is tested with every delivery, just as conformity tests are made to ensure the high quality standards of all our suppliers. It is no coincidence that almost all of the components used come from strictly Made in Italy manufacturers located only a short distance from our production facility.*

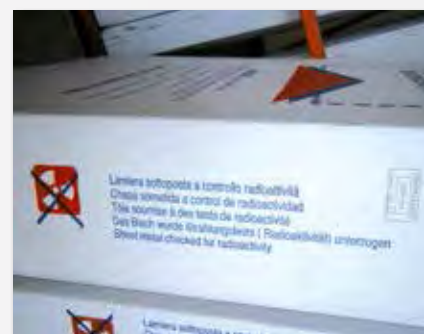

# Perché Essential by Scrigno

*Why you should choose Essential by Scrigno*

Qualità è un concetto che guida da sempre lo studio e la produzione della gamma Scrigno.

Essential by Scrigno rappresenta la sintesi perfetta di questa filosofia aziendale, fatta di scelte precise e senza compromessi, cercando la migliore componentistica e confrontandosi quotidianamente con chi il prodotto lo dovrà utilizzare.

*Quality is a concept that has always guided the design and production of the Scrigno range.*

*Essential by Scrigno is the perfect synthesis of this corporate philosophy, made up of precise choices and never compromising, always looking for only the best components and engaging in a constant dialogue with users of the company's products.*

## Essential Scorrevole • *Essential Sliding*



### **Sempre cassonetti a cassa piena**

Che sia intonaco o cartongesso, Scrigno sceglie sempre la solidità proponendo solo controltelai a cassa piena.

#### *Only full metal boxes*

*Whether its frames are intended for plasterwork or plasterboard finishes, Scrigno always opts for solidity, offering only full metal boxes.*



### **Ad ogni parete la giusta soluzione**

Essential significa 5 diverse soluzioni per 5 diversi spessori parete, dove velocità ed economicità di posa rappresentano il nostro leit motiv.

#### *The ideal solution for every wall*

*Essential means five different solutions for five different wall thicknesses, all characterized by fast and inexpensive installation.*



### **Fianco modulare**

Consente di assorbire al meglio le possibili dilatazioni dovute all'unione di materiali diversi, quali cemento e acciaio, garantendo una posa più facile, maggiore resistenza e migliore estetica della parete.

#### *Modular sides*

*These allow the possible expansion occurring between different materials like mortar and steel to be absorbed more efficiently, guaranteeing easier installation, greater strength and better visual results for finished walls.*



### **Lamiera in Aluzinc®**

Capace di garantire un'ottima resistenza alla corrosione, grazie alla combinazione tra zinco e alluminio, rende il prodotto adatto anche ad ambienti particolarmente aggressivi e riduce eventuali problemi di manutenzione.

#### *Aluzinc® sheet metal*

*Capable of ensuring excellent resistance to corrosion thanks to the combination of zinc and aluminium, making the product suitable even for harsh environmental conditions and reducing possible maintenance problems.*

# Perché Essential by Scigno

*Why you should choose Essential by Scigno*

## Essential Scorrevole • *Essential Sliding*



### Garanzia a vita

Grazie ai materiali utilizzati e a tutte le fasi del processo produttivo, è l'unico controtelaio garantito a vita contro la corrosione passante. Inoltre il sistema di scorrimento è garantito per 20 anni.

#### *Lifetime guarantee*

*The materials used and all phases of the production process make this the only sliding door frame with a lifetime guarantee against perforations caused by corrosion. The sliding system is also guaranteed for 20 years.*



### Facilità di posa e di regolazione

Grazie ai brevetti esclusivi Scigno, l'installazione del pannello porta è estremamente facile e precisa, garantendo la miglior regolazione per una resa estetica sempre perfetta.

#### *Easy door fitting and adjustment*

*Thanks to Scigno's exclusive patents, door panels can be fitted with extreme simplicity and precision, ensuring perfect adjustment for a final effect that is always flawless.*



### Massima personalizzazione

Con gli accessori Essential by Scigno, ferramenta per ante in vetro, sistemi di frenatura e automazione, fino alla soluzione doccia, il prodotto raggiunge massimi livelli di personalizzazione.

#### *Maximum personalization*

*The many accessories for the Essential by Scigno range, including hardware for glass doors and slow movement and automation systems through to the shower door solution, allow the product to achieve maximum levels of personalization.*



### Resistenza al fuoco

Essential scorrevole è disponibile anche in versione EI 30.

#### *Fire resistance*

*Essential Sliding doors are also available in an REI 30 fire-resistant version.*

# Essential Battente • Essential Swing

Telaio per Essential Battente  
Frame for Essential Swing door



Telaio Senza Traverso per Essential Battente  
Frame without upper crosspiece for Essential swing door



Telaio per Essential Battente Trapezoidale  
Trapezoidal shape frame for Essential swing door



## Massima robustezza

I telai Essential Battente si caratterizzano per la ricerca Scigno applicata ai profili, caratterizzati da cura del dettaglio e spessori importanti.

### Maximum robustness

*Essential Swing frames feature intense Scigno research applied to profile sections, focusing on extreme attention to details and significant timber thicknesses.*

Sono disponibili nella versione Battente, Battente Zero, Battente Senza Traverso e Battente Trapezoidale, singolo e doppio.

*Availables in four versions Swing, Swing Zero, Swing Without Upper Crosspiece and Swing Trapezoidal Shape, simple and double.*



## Lavorazione "a coda di rondine"

Per offrire la massima resa estetica e una grande facilità di rasatura della parete il telaio presenta una particolare lavorazione, a coda di rondine.

### Special surface grooves

*Frames have special surface grooves to ensure the finest visual results and extremely easy spreading of finishing plaster.*



## Due diversi profili

Non tutte le pareti sono uguali, per cui Scigno propone due profili, garantendo così sempre il miglior risultato estetico e funzionale.

### Two different profiles

*Not all walls are the same, so Scigno offers two different profiles to always guarantee the best possible visual and functional results.*

# Essential Battente • *Essential Swing*



## Ante di alta qualità ...

Con lo spessore di 55 mm, è possibile garantire il mantenimento nel tempo degli elevati standard di tenuta e allineamento richiesti da Scigno.

### *Doors of great quality...*

*With door thicknesses of 55 mm, the high standards of alignment and sealing against draughts required by Scigno can be guaranteed for many years*



## ... e sempre perfette.

Particolari aste raddrizzanti consentono ai pannelli superiori a 2100 mm di rimanere nella giusta posizione.

### *... and always perfect*

*Special straightener rods allow doors panels over 2100 mm to stay in the correct position.*



## Componenti di qualità

Le cerniere Essential by Scigno rappresentano la massima espressione tecnologica Made in Italy, grazie alla qualità della loro fattura, all'ampiezza delle regolazioni possibili, fino alla loro portata.

### *Quality components*

*Essential by Scigno hinges are the finest expression of Made-in-Italy technology, manufactured to superior standards and offering an ample range of adjustments and a high load-bearing capacity.*



## Resistenza al fuoco

Essential Battente è disponibile nella versione EI 30 e EI 60, completi di tutti i sistemi necessari per rispondere al meglio a tutti i requisiti europei e nazionali.

### *Fire resistance*

*Essential Swing is also available in fire-resistant REI 30 and REI 60 versions, complete with all systems necessary for full compliance with all Italian and European standards.*

# Essential: particolari

## *Essential: details*



Marchio su cerniera regolabile su 3 assi  
*Logo on hinge adjustable in 3 directions*



Esempio del contenuto scatola accessori per porta Essential Battente  
*Example of contents of installation accessories box for Essential Swing door*

La gamma Essential battente si caratterizza per l'elevata qualità tecnica per offrire il migliore risultato estetico. Dalle cerniere, ovviamente Made in Italy, alle serrature, alla laccatura fino allo spessore porta: ogni dettaglio tecnico rispecchia in pieno la qualità Scigno, sempre disponibile con scelte al millimetro, in versione tagliafuoco oppure trapezoidale e personalizzabile in una infinita gamma di colori, finiture e maniglie.

*The Essential Swing range is distinguished by high technical quality to offer the best possible visual results. From the hinges, which are obviously Made in Italy, through to locks, lacquer finishes and door thicknesses, every single technical detail fully reflects Scigno quality, always available with dimensions to the nearest millimetre, in fire-resistant or trapezoidal versions, and customizable with an infinite variety of colours, finishes and handles.*



Catenaccio superiore per porta fissa dell'anta doppia  
*Upper bolt for the fixed panel of the double door*



Catenaccio inferiore per porta fissa dell'anta doppia  
*Lower bolt for the fixed panel of the double door*



Marchio  
*Logo on door edge*

# Essential maniglie

*Essential handles*



Kit Chiudiscigno per porte a Battente  
*Kit Chiudiscigno for swing doors*



Kit Chiudiscigno - Rotonda con serratura  
*Kit Chiudiscigno - Round handles with lock*



Kit Chiudiscigno - Segno tonda magnetica con serratura  
*Kit Chiudiscigno - Segno magnetic round handles with lock*



Kit Chiudiscigno - Segno rettangolare magnetica con serratura  
*Kit Chiudiscigno - Segno magneti rectangular handles with lock*

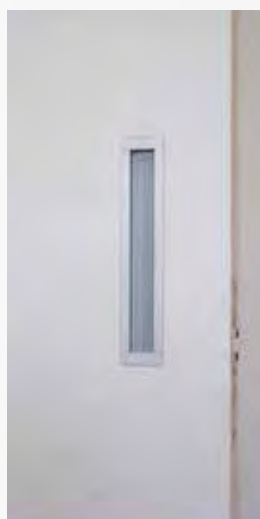

Maniglia Vaschetta  
*Handle Flush Pull*



Maniglia ricavata  
*Integrated handle*

# ESSENTIAL<sup>®</sup>

by SCRIGNO<sup>®</sup>

Nato nel 2000, brevetto esclusivo di Scigno per una nuova tipologia di controtelai per porte scorrevoli, Essential oggi è il marchio di una linea di soluzioni scorrevoli e porte a battente completa e qualificata. L'originario concetto, essenziale e minimalista per lasciare le pareti completamente prive di stipiti e altre finiture che ha generato "l'armonia tra porta e parete" si allarga alle porte a battente e ad altre tipologie di prodotti (ante per piccoli vani, botole...).

La linea infatti è oggi basata su Essential Scorrevole, Essential Trial, e Essential Dual per i sistemi scorrevoli, Essential Battente, Battente Zero, Essential Little, Little Zero, e Little cartongesso per le soluzioni battenti "filo parete".

*First created in 2000 and an exclusive Scigno patent for a new type of sliding door frame, Essential is now synonymous with a top-quality range of solutions for sliding and swing doors. Essential and minimalist, leaving walls completely free from door posts and other elements and creating harmony between walls and doors, the original concept now extends to swing doors and other products (doors for small spaces, hatches, etc.).*

*The range now includes Essential Sliding, Essential Trial and Essential Dual for sliding systems and Essential Battente, Battente Zero, Essential Little, Little Zero and Little Plasterboard for swing solutions flush with the wall.*

12	Essential Scorrevole   <i>Essential Sliding</i>
18	Essential Pro
20	Essential Scorrevole EI 30   <i>Sliding EI 30</i>
22	Essential: soluzione doccia <i>Essential: the shower solution</i>
26	Essential Trial
30	Essential Dual
32	Essential Battente   <i>Essential Swing</i>
38	Essential Battente Senza Traverso <i>Essential Swing Without Upper Crosspiece</i>
40	Essential Battente Trapezoidale <i>Essential Swing Trapezoidal Shape</i>
42	Essential Battente EI 30/60   <i>Essential Swing EI 30/60</i>
44	Essential Battente Zero   <i>Essential Swing Zero</i>
48	Essential Little   Essential Little Zero <i>Essential Little   Essential Little Zero</i>
52	Essential Little Cartongesso <i>Essential Little Plasterboard</i>
54	Porte   <i>Doors</i>
76	Soluzioni vetro   <i>Glass solutions</i>
86	Accessori e personalizzazioni <i>Accessories and customization options</i>
100	Dettagli tecnici controtelai <i>Technical details frames</i>
150	Dettagli tecnici porte <i>Technical details doors</i>



Essential Scorrevole, anta Trésor bianca, Kit Chiudiscrigno - Quadra • Essential Sliding, Trésor white door, Kit Chiudiscrigno - Quadra

# Essential Scorrevole

## *Essential Sliding*



È il controtelaio brevettato in esclusiva da Scigno.

Il sistema consente la scomparsa di una o due porte scorrevoli, armonizzandosi con la parete. Eliminati stipiti e cornici coprifilo, vengono adottati profili di alluminio sui quali viene direttamente rasato l'intonaco o il cartongesso. La stessa tinteggiatura dei profili e della parete completa il risultato estetico, proponendo una soluzione stilisticamente perfetta e pronta per ogni tipo di personalizzazione.

Disponibile anche in versione fuori misura con altezze variabili al centimetro.

Il sistema si abbina al meglio sia con ante in legno che con soluzioni in vetro, utilizzando i componenti della gamma Scigno.

*A frame system covered by an exclusive Scigno patent, allowing the installation of one or two disappearing sliding doors that match the wall.*

*The doorpost and edging trims have been replaced by aluminium profile bars, to be finished with the direct application of plasterwork or plasterboard, and then easily painted together with the walls to give the attractive final results.*

*Also available in non-standard sizes, with height variable in steps of one centimetre.*

Singolo - Single

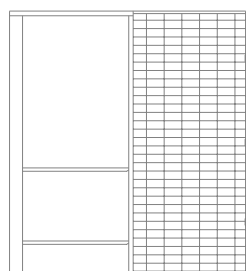

Doppio - Double

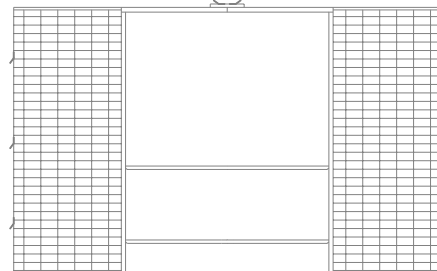



Essential Scorrevole, anta Comfort bianca, Kit Chiudiscigno - Quadra • *Essential Sliding, Comfort white door, Kit Chiudiscigno - Quadra*



Essential Scorrevole doppia, anta vetro trasparente con ferramenta Scrigno, maniglia Tube • *Essential double Sliding, transparent glass door with Scrigno hardware, handle Tube*



Essential Scorrevole singolo, anta vetro trasparente con ferramenta Scrigno • *Essential single Sliding, transparent glass door with Scrigno hardware*



Essential Scorrevole doppio, anta Comfort bianca, Kit Chiudiscigno - Quadra • *Essential double Sliding, Comfort white door, Kit Chiudiscigno - Quadra*

# Essential Pro

## Essential Pro

Essential Pro è una particolare versione di Essential scorrevole, che permette l'installazione del kit Scigno Open per l'automazione della porta scorrevole.

Scigno Open è un dispositivo molto semplice da installare; il gruppo motore, di dimensioni ridotte, è fissato alla guida del controtelaio e si cela totalmente, mantenendo inalterata l'estetica della porta, riducendo la luce di passaggio.

Il kit Open è installabile in qualunque momento semplicemente togliendo il pannello porta.

In assenza di motorizzazione Open, il controtelaio Essential Pro si comporta esattamente come un Essential tradizionale, consentendo quindi l'installazione di tutti gli accessori predisposti.

*Essential Pro is a special version of the sliding Essential frame, permitting the installation of the Scigno Open Kit for the automation of the sliding door. Scigno Open is an extremely easy device to install. The compact motor unit is fixed to the track of the frame and is totally concealed, ensuring that the attractiveness of the door remains unimpaired, reducing the effective clear opening size in width.*

*Without the Open automation kit, Essential Pro works in exactly the same way as a normal Essential frame, allowing all the available accessories to be fitted.*

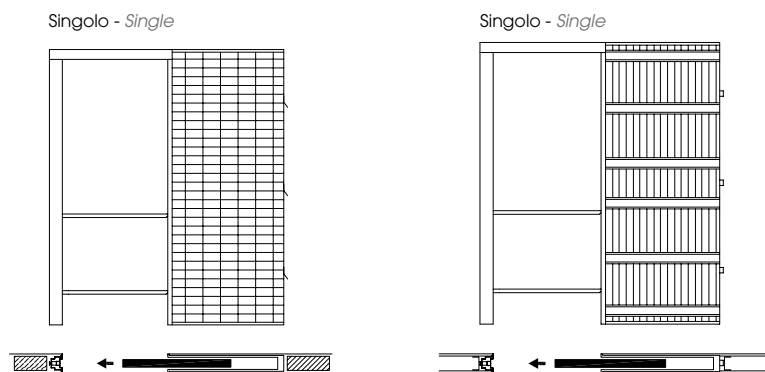



Essential Pro, anta Trésor bianca, Kit Chiudiscrigno - Rotonda • *Essential Pro, Trésor white door, Kit Chiudiscrigno - Round*



Essential EI 30 Scorrevole, Kit Chiudiscrigno - Quadra • Essential Sliding EI 30, Kit Chiudiscrigno - Quadra

# Essential Scorrevole EI 30

## *Essential Sliding EI 30*

Scrigno ha esteso le caratteristiche di resistenza fuoco al modello Essential scorrevole, mantenendo invariate tutte le caratteristiche estetiche e funzionali che lo contraddistinguono.  
Disponibile con resistenza fuoco:  
EI 30 - EI1 30.

Pannelli disponibili solo nella versione con fondo.  
Il prodotto può essere personalizzato con i seguenti accessori:

Kit Ammortizzatore  
Kit Chiudiporta  
Kit Chiudiscrigno con o senza serratura

Disponibile solo nella versione cartongesso.

*Scrigno has extended its fire resistance characteristics to Essential sliding door models, at the same time conserving all the features of appearance and functions that distinguish them.*

*Available with these fire-resistance ratings:*

- *Fire door 30 - EI1 30.*

*Door panels available exclusively ready to paint.  
The product can be customized with the following accessories:*

- *damper kit*
- *self-closing pocket door kit*
- *Kit Chiudiscrigno handles with and without lock.*

*Available only for plasterboard walls.*

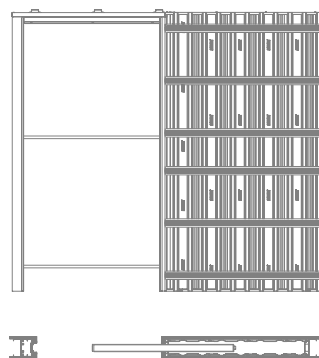

# Essential: soluzione doccia

## *Essential: the shower solution*

Scigno propone una soluzione innovativa per il mondo del bagno, presentando la prima porta scorrevole interno muro per box doccia.

Si caratterizza per essere capace di garantire alta funzionalità e purezza di design, poiché è stata appositamente concepita per docce a raso pavimento, che non richiedono quindi alcun piatto doccia. Uno speciale componente accessorio, coperto da brevetto esclusivo Scigno, consente al controtelaio Essential By Scigno di aprire nuove opportunità, libere da meccanismi e da impedimenti architettonici.

Lo speciale elemento consente il defluire delle acque, evitandone la fuoriuscita.

È perfettamente integrabile nel pavimento e personalizzabile secondo la pavimentazione prescelta.

Inoltre la sezione in luce è asportabile in qualunque momento garantendo estrema facilità di accesso agli scarichi per eventuale manutenzione e pulizia.

La soluzione doccia Essential by Scigno offre opportunità e facilità a coloro che, per qualunque motivo, trovano difficoltà di accesso al tradizionale box doccia, sia per la presenza del piatto, sia per le necessità di spazio richieste dalla rototraslazione della più tradizionale porta a battente.

E senza dimenticare gli innumerevoli vantaggi offerti dal controtelaio a scomparsa.

La soluzione Scigno è disponibile per aperture fino a 1200 mm, può inoltre essere abbinata ad altre specifiche opzioni, quali ad esempio lo specifico sistema di rallentamento in chiusura Slow Glass, che garantisce chiusure soft del cristallo.

*Scigno now offers an innovative solution for bathrooms, presenting the first shower cubicle door that slides effortlessly into the wall. This new product guarantees extreme functionality and purity of design, and was specifically developed for use in floor-level walk-in showers without a conventional shower tray.*

*A special floor accessory protected by an exclusive Scigno patent offers new opportunities to use Essential By Scigno frames, free from exposed mechanisms and architectural barriers.*

*The special accessory allows water to drain away easily, preventing overflows, and it fits conveniently into any floor to perfectly match any style of tiling chosen.*

*The accessory cover can also be removed at any time for easy access to drainage pipes for cleaning and maintenance.*

*The Essential by Scigno shower solution ensures easy access for everyone with difficulties of any kind in entering and using a conventional shower cubicle, due either to the presence of the shower tray or to the space needed for the opening of a normal swing door, in addition to all the other advantages offered by a disappearing sliding door.*

*This Scigno solution is available for openings up to 1200 mm, and it can also be combined with other options, like the special Slow Glass system, designed to ensure slow and gentle closure of the glass door.*

Particolare dell'elemento in alluminio e acciaio. Il prodotto è coperto da brevetto esclusivo Scigno e può essere installato solo su cassonetti Essential by Scigno nella parte inferiore.

*Detail of the steel and aluminium floor accessory. The product is covered by an exclusive Scigno patent, and can be installed only in conjunction with Essential by Scigno frames in the lower part.*





Essential soluzione doccia, anta vetro trasparente, maniglia Tube • *Essential shower solution, glass clear door, handle Tube*



Essential soluzione doccia, anta vetro trasparente, maniglia Tube • *Essential shower solution, glass clear door, handle Tube*



# Essential Trial

## Essential Trial

Essential Trial è il controtelaio nato dall'evoluzione di Essential e Essential Dual.

Rappresenta la sintesi della ricerca continua e del design di Scigno.

Un prodotto innovativo, capace di contenere, all'interno di un unico cassonetto a scomparsa, tre ante vetro scorrevoli collegate tra loro da un sistema di trascinamento.

Questo significa che è possibile avere ampie aperture, pur disponendo di ridotte dimensioni di parete per l'alloggiamento del controtelaio.

Il tutto armonizzandosi perfettamente con la parete che risulta libera da ogni finitura, grazie alla eliminazione di stipiti e cornici coprifilo.

È disponibile nella versione anta unica per pareti in muratura e per pareti in cartongesso.

Essential Trial dispone di accessori specifici per il rallentamento in chiusura e di maniglie dedicate in diverse finiture di colore.

*Essential Trial is a sliding door frame based on an evolution of Essential and Essential Dual, the result of constant research and design development by Scigno.*

*This innovative product can contain three disappearing sliding glass doors linked by a sliding system inside a single metal box.*

*This makes it possible to achieve particularly wide openings even when only small wall areas are available for the installation of the door frame.*

*The finished opening matches the wall perfectly, eliminating doorposts and edging trims and leaving it free from all exposed components.*

*Available in a single-door version for masonry walls and for plasterboard walls.*

*Essential Trial can be fitted with specific accessories for slow door closure and special handles in various colour finishes.*

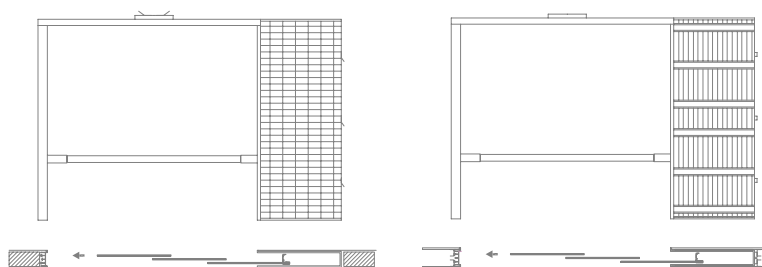



Essential Trial, ante vetro trasparente • *Essential Trial, glass clear doors*



Essential Trial, ante vetro trasparente • *Essential Trial, glass clear doors*



# Essential Dual

## Essential Dual

Brevetto esclusivo Scrigno, il contro telaio Essential Dual permette di contenere in un unico cassonetto due porte in vetro scorrevoli a scomparsa collegate tra loro da un sistema di trascinamento.

A questa particolarità si aggiungono il ridotto spessore parete - è utilizzabile in presenza di una normale parete con spessore di 10,5 cm - e lo spessore delle ante in vetro di 1 cm.

Il contro telaio è stato ridotto all'essenziale eliminando stipiti e cornici coprifilo.

È disponibile solo nella versione anta unica per pareti in muratura. Disponibile anche in versione fuori misura con altezze variabili al centimetro.

*An exclusive Scrigno patent, Essential Dual can contain two disappearing glass doors with a linked sliding system inside a single metal box.*

*This special feature is enhanced by the low wall thickness - Essential Dual can be installed inside a normal wall with a thickness of only 10.5 cm - and the 1 cm thickness of the glass doors.*

*The frame has been reduced to the minimum Essential, eliminating door posts and edging trims.*

*Available only in the single-door version for masonry walls.*

*Also available in non-standard sizes, with height variable in steps of one centimetre.*

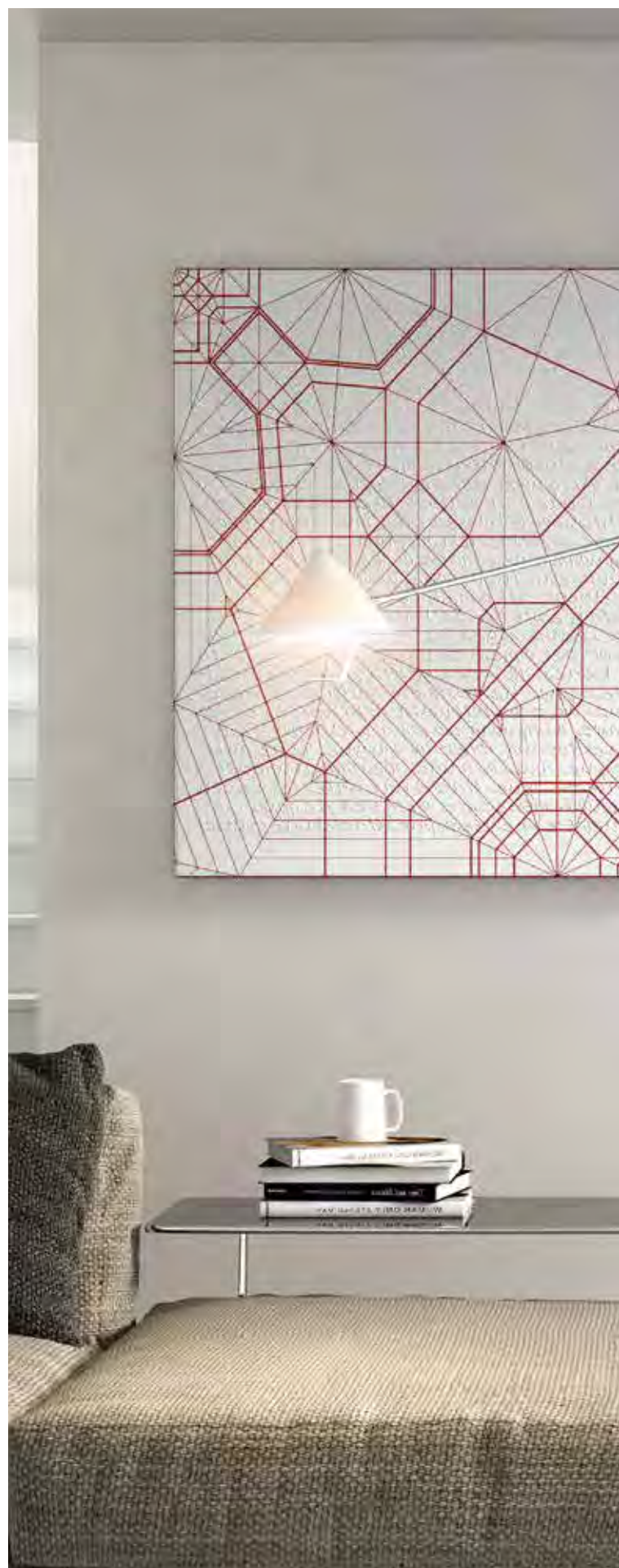
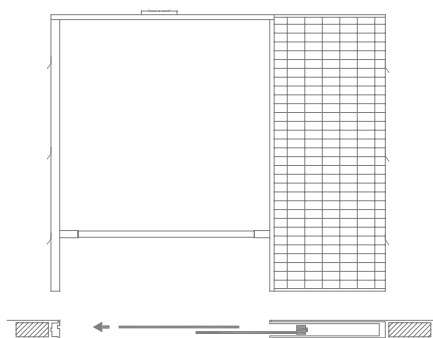



Essential Dual, ante vetro trasparente, maniglia Disco 80 • *Essential Dual, glass clear doors, handle Disco 80*



Essential Battente singola, Kit Chiudiscrigno per porta a Battente • *Essential Swing single door, Kit Chiudiscrigno for Swing door*

# Essential Battente

## Essential Swing



I prodotti della gamma Essential si ampliano ulteriormente completandosi con le porte della linea a battente, un sistema di porte filo parete.

La porta non necessita di cornici coprifilo, ha cerniere a scomparsa regolabili su 3 assi, si confonde con l'ambiente circostante.

Crea continuità con le pareti, protagoniste dello spazio: la porta appare completamente "fusa" con il muro.

Le porte della linea Essential filo parete sono disponibili in due varianti: Essential Battente, che presenta la classica fuga tra anta e telaio ed Essential Battente Zero, la versione senza fuga.

Le porte Essential possono essere installate sia in pareti in muratura che in cartongesso.

*The products of the Essential range are completed by a line of swinging doors, featuring doors flush with the wall. The door needs no edging trims and has concealed hinges adjustable in three directions, blending even more integrally into its surroundings. It creates continuity with the walls, the absolute protagonists of the space, and seems to be totally amalgamated into the wall.*

*Essential flush doors are available in two versions: Essential Battente, with the classic slight gap between door and frame, and Essential Battente Zero, the gapless version. Essential doors can be fitted on both masonry and plasterboard walls.*

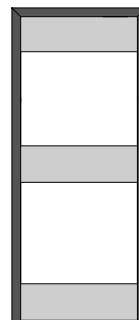



Essential Battente singola, Kit Chiudiscigno per porta a Battente • *Essential Swing single door, Kit Chiudiscigno for Swing door*



Essential Battente doppia, Kit Chiudiscrigno per porta a Battente • *Essential Swing double door, Kit Chiudiscrigno for Swing door*



Essential Battente singola, Kit Chiudiscigno per porta a Battente • *Essential Swing single door, Kit Chiudiscigno for Swing door*



# Essential Battente Senza Traverso

## *Essential Swing Without Upper Crosspiece*

Ampia libertà di espressione con Essential Battente Senza Traverso, che garantisce la possibilità di soluzioni porta a tutta parete. Non ci sono limiti alla creatività quando tutti i dettagli tecnici sono concepiti per offrire la massima garanzia di risultato e di durata nel tempo. Essential Battente Senza Traverso significa entrare in un concetto innovativo di apertura dove porta e parete si fondono completamente.

*Maximum freedom of expression with Essential Swing Without Crosspiece, which guarantees the possibility of doors occupying an entire wall.*

*There are no limits to your creativity when all technical details are designed to offer the maximum guarantee of excellent results and long duration. Essential Swing Without Crosspiece means exploring an innovative concept of opening, where doors and walls merge seamlessly.*

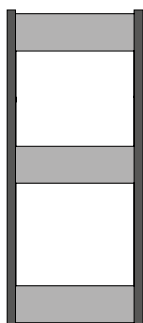



Essential Battente Senza Traverso, Kit Chiudiscigno per porta a Battente • *Essential Swing Without Upper Crosspiece, Kit Chiudiscigno for Swing door*



Essential Battente Trapezoidale, Kit Chiudiscrigno per porta a Battente • *Essential Swing Trapezoidal Shape, Kit Chiudiscrigno for Swing door*

# Essential Battente Trapezoidale

## *Essential Swing Trapezoidal Shape*

Non tutte le pareti sono uguali e Scigno lo sa perfettamente. Con Trapezoidale basta scegliere l'inclinazione del traverso, da 60 a 89° ed anche i soffitti più particolari avranno la loro porta. E' la soluzione ideale per mansarde e per ogni altro luogo dove il vostro estro lo richiederà.

*As Scigno is perfectly aware, not all walls are the same. With Essential Trapezoidal, just choose the angle of the crosspiece, from 60° to 89°, and even the most unusually shaped attics can have a perfect door.*

*This is the ideal solution for loft conversions and for any other situations that your creativity suggests.*

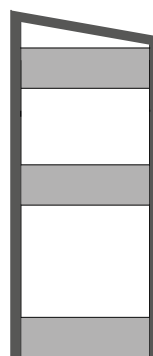

# Essential Battente EI 30/60

## *Essential Swing EI 30/60*

Scigno ha esteso le caratteristiche di resistenza fuoco al modello Essential battente, mantenendo invariate tutte le caratteristiche estetiche e funzionali che lo contraddistinguono.

Caratteristiche tecniche Essential X122.

Disponibile con resistenza fuoco:

- EI 30 - EI 30
- EI 60 - EI 60

Certificate secondo UNI EN 1634-1:2009

Pannelli disponibili solo nella versione con fondo.

E' inoltre possibile personalizzare il prodotto con diversi accessori e sistemi di apertura e chiusura.

*Scigno has extended its fire resistance characteristics to Essential Swing door models, at the same time conserving all the features of appearance and functions that distinguish them.*

*Technical features Essential X122*

- EI 30 - EI 30
- EI 60 - EI 60

*Certified according UNI EN 1634-1: 2009*

*Door panels available exclusively ready to paint.*

*The product can also be personalized with various accessories and systems for door opening and closing.*

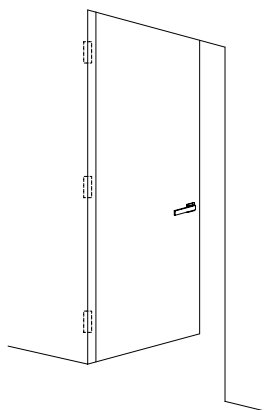



Essential Battente EI 30/60, Kit Chiudiscigno per porte a Battente • *Essential Swing EI 30/60, Kit Chiudiscigno for Swing door*



Essential Battente Zero, Kit Chiusdiscrigno per porta a Battente • *Essential Swing Zero, Kit Chiusdiscrigno for Swing door*

# Essential Battente Zero

## *Essential Swing Zero*

Il massimo del minimalismo. Battente Zero rappresenta la frontiera più estrema della porta che scompare, presentando luci pressoché inesistenti tra pannello e struttura, grazie alle speciali sagome di porta e telaio. Il tutto è concepito per offrire il miglior risultato estetico di perfetta integrazione nella parete.

*The maximum of minimalism. Swing Zero is the extreme frontier of concealed doors, with a virtually invisible gap between the door panel and the supporting structure, thanks to the special door and frame profiles. The entire assembly is designed to offer the best possible visual results, with the door merging perfectly into the wall.*

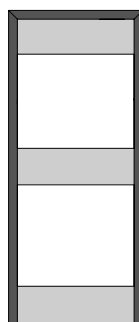



Essential Battente Zero, Kit Chiusdiscrigno per porta a Battente • *Essential Swing Zero, Kit Chiusdiscrigno for Swing door*



Essential Battente Zero, Kit Chiusdiscrigno per porta a Battente • *Essential Swing Zero, Kit Chiusdiscrigno for Swing door*

# Essential Little e Little Zero

## *Essential Little and Little Zero*

Essential Little rappresenta un sistema di sportelli filo parete che non richiedono l'utilizzo di cornici coprifilo, hanno cerniere a scomparsa con aperture a 90° e sono pensati come chiusure speciali per piccoli vani.

I pannelli - orizzontali, verticali, rettangolari, possono essere verniciati, laccati o ricoperti con carte da parati.

Disponibili in due modelli:

- Essential Little che presenta la fuga tra sportello e telaio,
- Essential Little Zero la variante senza fuga

Essential Little e Little Zero possono essere installati in pareti di qualsiasi spessore sia in muratura sia in cartongesso.

La forma trapezoidale non è disponibile nella variante Little Zero.

*Essential Little is a line of small doors fitted flush with the wall without edging trims and complete with concealed hinges opening through 90°, designed to provide special closures for small spaces.*

*The panels - horizontal, vertical, rectangular - can be painted, lacquered or covered with wallpaper.*

*Available in two models:*

- *Essential Little with a slight gap between the frame and the door;*
- *Essential Little Zero with no gap.*

*Essential Little and Little Zero can be installed on walls of any thickness, in either masonry or plasterboard.*

*The trapezoidal shape is not available for the Little Zero version.*





# Essential Little

Essential Little

Apertura laterale • Side opening



Apertura orizzontale a ribalta • Upwards horizontal opening

Apertura orizzontale a vasistas • Downwards horizontal opening



Apertura laterale • Side opening

Apertura laterale • Side opening



Apertura orizzontale a ribalta • Upwards horizontal opening

Apertura orizzontale a vasistas • Downwards horizontal opening



Apertura laterale • Side opening

# ■ Essential Little Zero

## *Essential Little Zero*

Apertura orizzontale a vasistas (fuga minimale)  
con maniglia premi - apri  
*Downwards horizontal opening (minimum gap)  
with handle awards-open*

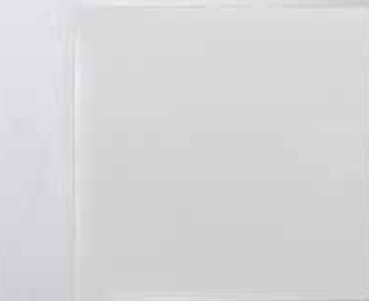

Apertura laterale (fuga minimale) con maniglia premi - apri  
*Downwards horizontal opening (minimum gap)  
with handle awards-open*



Serratura aperta, pomolo a sporgere  
*Lock open, knob out*

Apertura orizzontale a vasistas (fuga minimale)  
con maniglia premi - apri  
*Downwards horizontal opening (minimum gap)  
with handle awards-open*



Apertura laterale (fuga minimale) con maniglia premi - apri  
*Downwards horizontal opening (minimum gap)  
with handle awards-open*



Serratura chiusa, pomolo filo pannello  
*Lock closed, knob flush with door*



Essential Little Cartongesso da soffitto  
*Essential Little Plasterboard for ceiling*



Apertura laterale • *Side opening*



Apertura orizzontale a ribalta • *Upwards horizontal opening*

# Essential Little cartongesso

## *Essential Little plasterboard*

I modelli della linea Essential Little Cartongesso rappresentano particolari chiusure, botole e sportelli d'ispezione, nate specificatamente per le pareti in cartongesso.

Realizzati interamente in cartongesso (telaio e coperchio) si possono montare verticalmente o orizzontalmente esclusivamente in pareti di cartongesso.

Il pannello di chiusura può essere verniciato, laccato o ricoperto con carte da parati fondendosi con l'ambiente e scomparendo praticamente dalla vista.

Quattro i modelli disponibili:

- con coperchio e agganci magnetici senza cerniere,
- con cerniere con apertura a 90°,
- con apertura a soffitto con coperchio rimovibile verso l'interno (solo per botole a soffitto),
- con chiusura premi-apri (solo per modello Little).

*The models of the Essential Little Plasterboard range are special closures, trapdoors and inspection hatches that have been designed for fitting on plasterboard walls.*

*Made entirely from plasterboard (frame and cover), these accessories can be installed vertically or horizontally on plasterboard walls only.*

*The closure panels can be painted, lacquered or covered with wallpaper, blending into their surroundings and becoming practically invisible.*

*Four models are available,*

- *with cover and magnetic catches without hinge,*
- *with hinge opening through 90°, and with ceiling opening*
- *with cover removable towards the interior (for ceiling trapdoors only),*
- *with push-open system (only for Little).*

# PORTE BY SCRIGNO

## Porte Scorrevoli per Essential *Sliding doors for Essential*

Scrigno rivoluziona la sua offerta di gamma lanciando sul mercato due nuove linee di porte scorrevoli e a battente, COMFORT e TRESOR.

Le porte scorrevoli Scrigno sono in grado di rispondere alle esigenze di chi cerca soluzioni semplici ed eleganti per ottimizzare gli spazi della propria abitazione o ufficio.

Acquistare una porta Scrigno significa scegliere un prodotto di altissima qualità e affidabilità.

La cura dei particolari e delle finiture è in grado di soddisfare innumerevoli soluzioni d'arredo in modo sobrio, elegante e finemente personalizzato.

Le soluzioni proposte da Scrigno sono completate da un'ampia scelta di maniglie e serrature perfettamente abbinabili al modello di porta desiderato.

*Scrigno has revolutionized its product range by releasing COMFORT and TRÉSOR onto the market, two new lines of sliding doors.*

*Scrigno sliding doors can fully satisfy the needs of users looking for simple and elegant solutions to optimize space in home or office applications.*

*Buying a Scrigno door means choosing a product of exceptionally high quality and reliability.*

*The attention dedicated to details and finishes allows Scrigno doors to be used in countless decor schemes, always giving refined and elegant results that can be tastefully personalized.*

*The solutions offered by Scrigno are completed by an ample variety of locks and handles that perfectly match the door model chosen.*



La tecnica nella sua forma migliore  
*Technology in its best possible form*

- 56 Scorrevole per Essential | *Sliding for Essential*
- 58 Prima Scorrevole | *Prima Sliding*
- 60 Sound Scorrevole | *Sound Sliding*

# Scorrevole per Essential

## *Sliding for Essential*

Comfort è la nuova linea di porte scorrevoli, che offre un ventaglio di soluzioni sobrie ed eleganti, in linea con le esigenze di arredamento di interni.

Due sono i modelli proposti: Prima, versione con anta liscia e Sound, impreziosita da due inserti orizzontali in acciaio satinato.

Le porte Comfort sono pensate per i controtelai Scrigno, nelle versioni anta singola e doppia.

Comfort è offerta in una gamma di finiture moderne e di assoluta qualità; capace in pieno di assecondare le più recenti tendenze del mercato. Tutta la gamma è disponibile nei colori: bianco, palissandro bianco, venato bianco, rovere e rovere antracite.

*Comfort is a new range of sliding doors offering a variety of refined and elegant solutions suitable for all interior design needs.*

*The range has two models, Prima with a smooth panel and Sound, enhanced with two horizontal inserts in satin-finished steel.*

*Comfort doors are designed for Scrigno door frames, in versions with single or double.*

*Comfort doors are available in a range of modern finishes of absolute quality, capable of fully satisfying all the latest market trends.*

*The entire range is available in white, white rosewood, veined white, oak and anthracite oak*

Gamma colori - Range colors

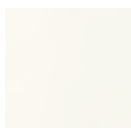

Bianco  
White

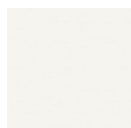

Venato Bianco  
Veined White

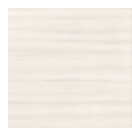

Palissandro Bianco  
Rosewood White



Rovere Antracite  
Anthracite oak



Rovere  
Oak





Essential Scorrevole, anta Comfort rovere, Kit Chiudiscigno - Quadra • *Essential Sliding, Comfort Oak door, Kit Chiudiscigno - Quadra*



Prima Scorrevole per Essential  
Bianco  
*Prima Sliding for Essential  
White*



Prima Scorrevole per Essential  
Venato Bianco  
*Prima Sliding for Essential  
Veined White*



Prima Scorrevole per Essential  
Palissandro Bianco  
*Prima Sliding for Essential  
Rosewood White*

La porta COMFORT è concepita per abbinarsi al meglio alla gamma di controtelai Scrigno.

L'MDF vanta un profilo ecologico che lo rende non dannoso sia per la salute sia per l'ambiente. È un pannello realizzato con recuperi di lavorazione del legno e la sua produzione non implica l'abbattimento sistematico di tronchi d'albero. Inoltre la superficie dei pannelli MDF è costituita da strati di decoro ad alta qualità, impregnati di una resina melaminica trasparente a base d'acqua (ossia senza solventi organici). Una volta galvanizzato, forma una superficie resistente agli agenti chimici, all'acqua, ai solventi organici, alla luce e alla temperatura. I decori sono stampati utilizzando tecnologie moderne con inchiostri.

# Prima Scorrevole

## Prima Sliding



Prima Scorrevole per Essential  
Rovere Antracite

*Prima Sliding for Essential  
Anthracite oak*



Prima Scorrevole per Essential  
Rovere

*Prima Sliding for Essential  
Oak*

*Comfort doors are designed for a suitable match to Scrigno frames systems range .*

*Medium-density fibreboard (MDF) has an ecological profile that makes it safe both for health and for the environment. MDF panels are made using recycled wood processing wastes, and their production does not require the systematic felling of tree trunks. In addition, MDF panels have a surface composed of layers of high-quality decorative materials, impregnated with transparent water-based melamine resins that are free from organic solvents. After hardening, these resins form a surface that is resistant to chemical agents, water, organic solvents, light and temperature. Decorations are printed using modern ink technologies. MDF has an ecological profile.*

# Sound scorrevole ■

## *Sound Sliding*

Con inserti orizzontali in acciaio satinato.



Sound Scorrevole per Essential  
Bianco  
*Sound Sliding for Essential  
White*



Sound Scorrevole Essential Sound  
Venato Bianco  
*Sound Sliding for Essential  
Veined White*



Sound Scorrevole per Essential  
Palissandro Bianco  
*Sound Sliding for Essential  
Rosewood White*

La porta COMFORT è concepita per abbinarsi al meglio alla gamma di controtelai Scigno.

L'MDF vanta un profilo ecologico che lo rende non dannoso sia per la salute sia per l'ambiente. È un pannello realizzato con recuperi di lavorazione del legno e la sua produzione non implica l'abbattimento sistematico di tronchi d'albero. Inoltre la superficie dei pannelli MDF è costituita da strati di decoro ad alta qualità, impregnati di una resina melaminica trasparente a base d'acqua (ossia senza solventi organici). Una volta galvanizzato, forma una superficie resistente agli agenti chimici, all'acqua, ai solventi organici, alla luce e alla temperatura. I decori sono stampati utilizzando tecnologie moderne con inchiostri.

*With horizontal inserts in satin-finished steel.*



Sound Scorrevole per Essential  
 Rovere Antracite  
 Sound Sliding for Essential  
 Anthracite oak



Sound Scorrevole per Essential  
 Rovere  
 Sound Sliding for Essential  
 Oak

*Comfort doors are designed for a suitable match to Scigno frames systems range .*

*Medium-density fibreboard (MDF) has an ecological profile that makes it safe both for health and for the environment. MDF panels are made using recycled wood processing wastes, and their production does not require the systematic felling of tree trunks. In addition, MDF panels have a surface composed of layers of high-quality decorative materials, impregnated with transparent water-based melamine resins that are free from organic solvents. After hardening, these resins form a surface that is resistant to chemical agents, water, organic solvents, light and temperature. Decorations are printed using modern ink technologies. MDF has an ecological profile.*



# TRÉSOR

Un mondo di colore

*A world of color*

64 Scorrevole per Essential | *Sliding for Essential*

66 Pure Scorrevole | *Pure Sliding*

68 Linea Scorrevole | *Linea Sliding*

70 Battente per Essential | *Swing for Essential*

72 Pure Battente | *Pure Swing*

74 Linea Battente | *Linea Swing*



Essential Scorrevole, anta Trésor Ral 1015 frassinata, Kit Chiudiscigno - Quadra • *Essential Sliding, Trésor Ral 1015 ash door, Kit Chiudiscigno - Quadra*

# Scorrevole per Essential

## *Sliding for Essential*

Trésor significa entrare in un mondo infinito di colore: una linea di porte appositamente studiata per tutti i prodotti della gamma Scigno e personalizzabile in ogni suo aspetto.

Due sono i modelli di porta proposti, Pure con anta liscia e Linea, impreziosita da due fresate orizzontali, a loro volta disponibili in versione laccata opaca o lucida e frassino poro aperto laccato opaco.

La gamma propone una serie di 8 colori RAL standard, mentre è possibile la totale personalizzazione accedendo all'intera gamma RAL, così come modificare l'altezza del pannello fino a 2700 mm.

*Trésor means entering a world of infinite colors, with a line of fully-customizable doors specifically designed to fit all products of the Scigno range.*

*The two models of the Trésor line are Pure, with a smooth door panel, and Linea, enhanced with two machined horizontal grooves, and finishes include matt lacquer and acquired and gloss open-pore ash.*

*Eight standard RAL colors are available, but on request any other color from the entire RAL range can be chosen, together with door heights varying up to 2700 mm.*



Gamma colori - Range colors

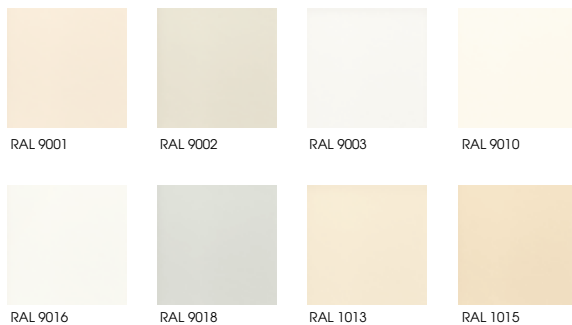

Personalizzazione totale dell'anta con tutta la gamma RAL, anche in versione frassinata.  
*Any other color from the entire RAL range can be chosen, available also gloss open-pore ash.*



Pure Scorrevole - RAL 9001  
Pure Sliding - RAL 9001



Pure Scorrevole - RAL 9002  
Pure Sliding - RAL 9002



Pure Scorrevole - RAL 9003  
Pure Sliding - RAL 9003



Pure Scorrevole - RAL 9010  
Pure Sliding - RAL 9010

Disponibile anche in versione frassinata / Available also gloss open-pore ash

# Pure Scorrevole

*Pure Sliding*



Pure Scorrevole - RAL 9016  
*Pure Sliding - RAL 9016*



Pure Scorrevole - RAL 9018  
*Pure Sliding - RAL 9018*



Pure Scorrevole - RAL 1013  
*Pure Sliding - RAL 1013*



Pure Scorrevole - RAL 1015  
*Pure Sliding - RAL 1015*

# Linea Scorrevole

## *Linea Sliding*

Con inserti orizzontali in acciaio satinato / *With horizontal inserts in satin-finished steel.*



Linea Scorrevole - RAL 9001  
*Linea Sliding - RAL 9001*



Linea Scorrevole - RAL 9002  
*Linea Sliding - RAL 9002*



Linea Scorrevole - RAL 9003  
*Linea Sliding - RAL 9003*

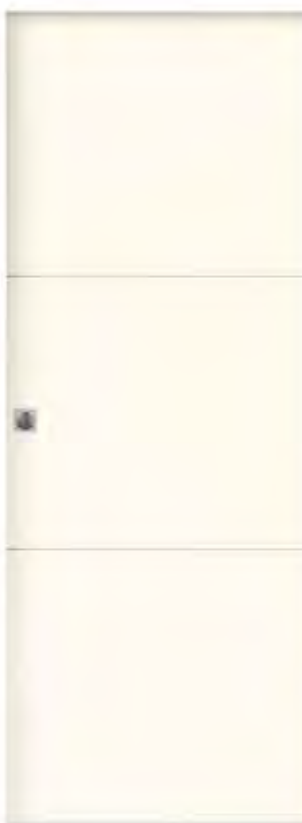

Linea Scorrevole - RAL 9010  
*Linea Sliding - RAL 9010*

Disponibile anche in versione frassinata / *Available also gloss open-pore ash*



Linea Scorrevole - RAL 9016  
*Linea Sliding - RAL 9016*



Linea Scorrevole - RAL 9018  
*Linea Sliding - RAL 9018*

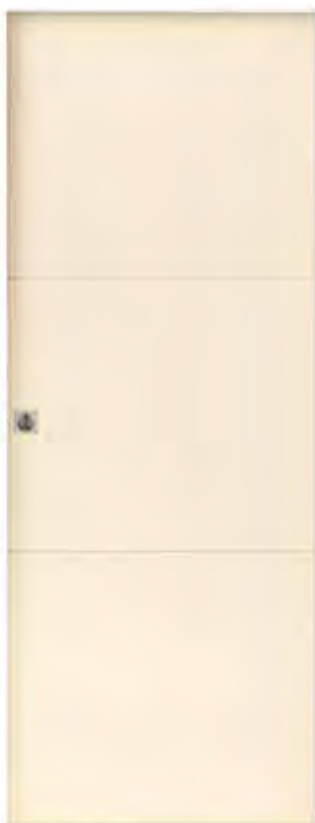

Linea Scorrevole - RAL 1013  
*Linea Sliding - RAL 1013*



Linea Scorrevole - RAL 1015  
*Linea Sliding - RAL 1015*



Essential Battente, anta Trésor Ral 9018, Kit Chiudiscrigno per porte a Battente • *Essential Swing, Trésor Ral 9018 door, Kit Chiudiscrigno for Swing door*

# Battente per Essential

## *Swing for Essential*

Trésor significa una gamma completa di porte, anche per Essential Battente.

Due modelli di porte, Pure e Linea, in versione liscia e frassinata, con 8 finiture Ral standard, accesso a tutta la gamma Ral, lucida e opaca: una moltitudine di combinazioni perchè ogni porta sia unica.

*Trésor offers a complete range of doors for Essential Swing as well.*

*Eight finishes in standard RAL colours and by request all other RAL colours, with matt or gloss lacquer, giving a vast number of combinations to make every choice truly unique.*

*The two door models, Pure and Linea, are available in smooth or ash versions.*

Gamma colori - Range colors

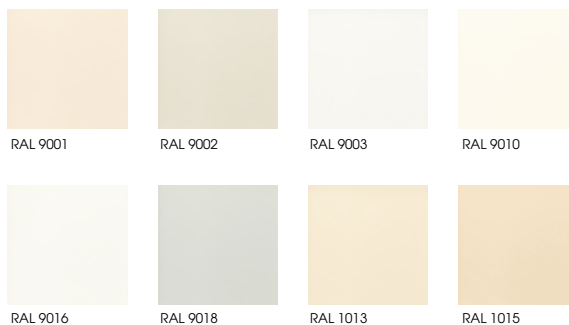

Personalizzazione totale dell'anta con tutta la gamma RAL, anche in versione frassinata.  
*Any other color from the entire RAL range can be chosen, available also gloss open-pore ash.*

# Pure Battente

## Swing



Particolare cerniera a scomparsa  
*Concealed hinge detail*



Pure Battente - RAL 9001  
*Pure Swing - RAL 9001*

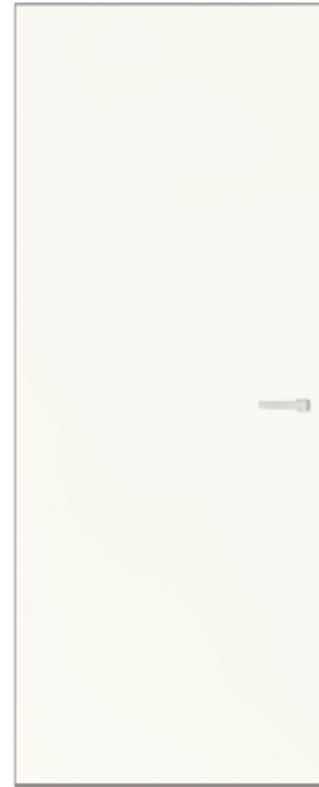

Pure Battente - RAL 9002  
*Pure Swing - RAL 9002*



Particolare maniglia per porta battente  
e serratura magnetica  
*Door handle for swing door detail and  
magnetic lock*

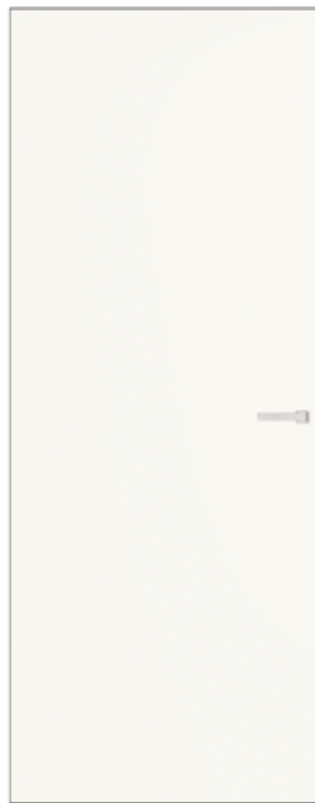

Pure Battente - RAL 9003  
*Pure Swing - RAL 9003*

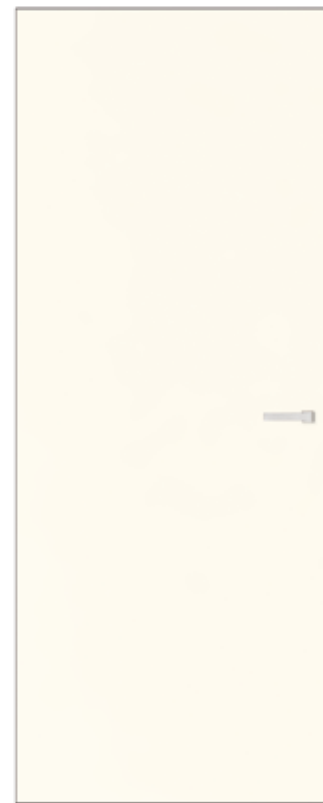

Pure Battente - RAL 9010  
*Pure Swing - RAL 9010*

Disponibile anche in versione frassinata / Available also gloss open-pore ash

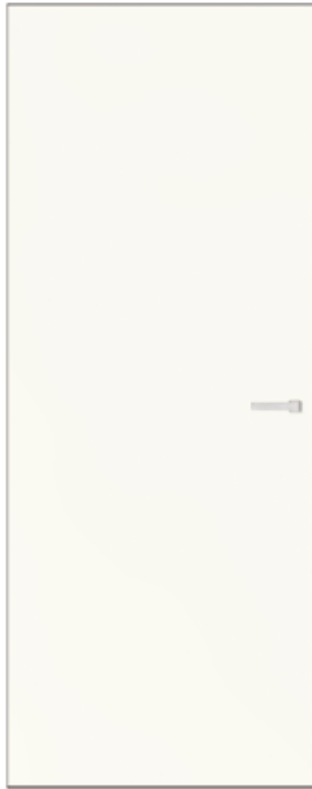

Pure Battente - RAL 9016  
*Pure Swing - RAL 9016*



Pure Battente - RAL 9018  
*Pure Swing - RAL 9018*

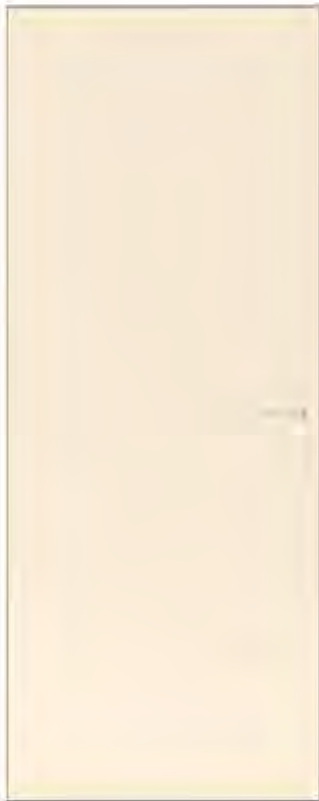

Pure Battente - RAL 1013  
*Pure Swing - RAL 1013*



Pure Battente - RAL 1015  
*Pure Swing - RAL 1015*

Con inserti orizzontali in acciaio satinato / *With horizontal inserts in satin-finished steel.*



Particolare cerniera a scomparsa  
*Concealed hinge detail*



Particolare fresatura  
*Close-up of machined groove*



Particolare maniglia per porta battente  
e serratura magnetica  
*Door handle for swing door detail and  
magnetic lock*



Linea Battente - RAL 9001  
*Linea Swing - RAL 9001*



Linea Battente - RAL 9002  
*Linea Swing - RAL 9002*



Linea Battente - RAL 9003  
*Linea Swing - RAL 9003*



Linea Battente - RAL 9010  
*Linea Swing - RAL 9010*

Disponibile anche in versione frassinata / *Available also gloss open-pore ash*

# Linea Battente

*Swing*



Linea Battente - RAL 9016  
*Linea Swing - RAL 9016*



Linea Battente - RAL 9018  
*Linea Swing - RAL 9018*



Linea Battente - RAL 1013  
*Linea Swing - RAL 1013*



Linea Battente - RAL 1015  
*Linea Swing - RAL 1015*



Soluzioni vetro  
*Glass solutions*

- 78 Anta vetro per Essential | *Sliding glass doors for Essential*
- 80 Anta vetro per Essential Trial | *Glass door for Essential Trial*
- 82 Anta vetro per Essential Dual | *Glass door for Essential Dual*
- 84 Acqua per Essential | *Acqua for Essential*



Essential Scorrevole singolo, anta vetro acidato, con ferramenta Scigno, maniglia Tube • *Essential single Sliding, etched glass door with Scigno hardware, handle Tube*

# Anta vetro per Essential

## Glass door for Essential

Estrema purezza di design anche nella soluzione vetro per Essential. Il kit prevede pinze a pressione ad altissima tenuta che non necessitano di alcuna foratura sul vetro.

Sono applicabili su lastre vetro a spessore variabile (8 o 10 mm).

E' inoltre previsto un distanziale posteriore per la regolazione della fuoriuscita dell'anta.

Su questo prodotto è installabile il rallentatore in chiusura Slow Glass, appositamente studiato per garantire una chiusura rallentata della lastra.

Il carter di copertura è fornibile in due finiture, alluminio anodizzato e simil inox.

Tutti i componenti sono vendibili separatamente.

L'anta in vetro è realizzabile al centimetro.

*Glass doors for the Essential frame offer extreme purity of design. The kit includes strongly gripping pressure clamps that eliminate the need to drill holes in glass.*

*Can be fitted only on glass panels of variable thickness (8 or 10 mm).*

*A rear spacer is also provided for adjustment of the projection of the panel.*

*This product can be fitted with the Slow Glass system, specifically designed to ensure slow door closure.*

*The protection cover is available in anodized aluminium or stainless steel effect finishes.*

*All components can be sold separately.*

*Glass doors are available in sizes varying in steps of 1 cm.*

### Vetri - Glasses



Trasparente  
Clear glass



Acidato  
Etched glass



Trasparente  
extra chiaro  
Extra clear glass

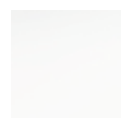

Acidato  
extra chiaro  
Etched glass extra clear



Bronzo  
Bronze glass



Grigio fumé  
Grey glass

### Finiture carter - Protection cover finish

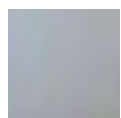

Alluminio anodizzato  
Anodized aluminium

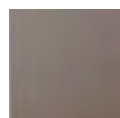

Simil inox  
Stainless steel effect

# Anta vetro per Essential Trial

## *Glass door for Essential Trial*

Essential Trial è il controtelaio nato dall'evoluzione di Essential e Essential Dual. Rappresenta la sintesi della ricerca continua e del design di Scrigno.

Un prodotto innovativo, capace di contenere, all'interno di un unico cassonetto a scomparsa, tre ante vetro scorrevoli collegate tra loro da un sistema di trascinamento.

Questo significa che è possibile avere ampie aperture, pur disponendo di ridotte dimensioni di parete per l'alloggiamento del controtelaio.

Il tutto armonizzandosi perfettamente con la parete che risulta libera da ogni finitura, grazie alla eliminazione di stipiti e cornici coprifilo.

È disponibile nella versione anta unica per pareti in muratura e per pareti in cartongesso.

I vetri, di spessore 10 mm, sono fornibili in sei finiture: acidato, trasparente, acidato extra chiaro, trasparente extra chiaro, bronzo e grigio fumé.

E' possibile personalizzare il prodotto, attraverso la scelta della maniglia, la scomparsa totale dell'anta o meno all'interno del cassonetto e la scelta di un sistema dedicato di rallentamento in chiusura.

*Essential Trial is a sliding door frame based on an evolution of Essential and Essential Dual, the result of constant research and design development by Scrigno.*

*This innovative product can contain three disappearing sliding glass doors linked by a sliding system inside a single metal box.*

*This makes it possible to achieve particularly wide openings even when only small wall areas are available for the installation of the door frame.*

*The finished opening matches the wall perfectly, eliminating doorposts and edging trims and leaving it free from all exposed components.*

*Available in a single-door version for plastered walls and for plasterboard walls.*

*The glass panels, with a thickness of 10 mm, are available with a: etched glass, clear glass, etched glass extra clear, extra clear glass, bronze glass and grey fumé.*

*The product can be customized with the choice of handles, total or partial disappearance into the frame, and the fitting of a slow closure system.*



### Vetri - Glasses



Trasparente  
Clear glass



Acidato  
Etched glass



Trasparente  
extra chiaro  
Extra clear glass

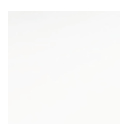

Acidato  
extra chiaro  
Etched glass extra clear

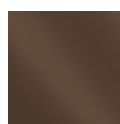

Bronzo  
Bronze glass



Grigio fumé  
Grey glass



Essential Trial, ante vetro trasparente • *Essential Trial, glass clear doors*



Essential Dual, ante vetro trasparente, maniglia Disco 80 • *Essential Dual, glass clear doors, handle Disco 80*

# Anta vetro per Essential Dual

## *Glass door for Essential Dual*



Brevetto esclusivo Scigno, il contro telaio Essential Dual permette di contenere in un unico cassonetto due porte in vetro scorrevoli a scomparsa collegate tra loro da un sistema di trascinamento.

A questa particolarità si aggiungono il ridotto spessore parete - è utilizzabile in presenza di una normale parete con spessore di 10,5 cm - e lo spessore delle ante in vetro è di 1 cm.

Il contro telaio è stato ridotto all'essenziale eliminando stipiti e cornici coprifilo.

È disponibile solo nella versione anta unica per pareti in muratura. Disponibile anche in versione fuori misura con altezze variabili al centimetro.

E' possibile optare per l'anta vetro, già completa di tutti i componenti necessari al montaggio, o per il solo kit ferramenta.

I vetri sono fornibili in finitura trasparente o acidata.

*An exclusive Scigno patent, Essential Dual is an innovative product that can contain two disappearing glass doors with a linked sliding system inside a single metal box.*

*This special feature is enhanced by the low wall thickness - Essential Dual can be installed inside a normal wall with a thickness of only 10.5 cm - and the 1 cm thickness of the glass doors.*

*The frame has been reduced to the minimum essential, eliminating door posts and edging trims.*

*Available only in the single-door version for masonry walls. Also available in non-standard sizes, with height variable in steps of one centimetre.*

*Possibility of buying either finished doors complete with all assembly components or the hardware kit only.*

*Glass can be supplied with either a transparent or frosted finish.*

Vetri - Glasses



Trasparente  
Clear glass



Acidato  
Etched glass

# Acqua per Essential

## Acqua for Essential

Acqua è la porta scorrevole in vetro disponibile per Essential.

Le ante Acqua, dalla linea semplice e sottile sono dotate di struttura in alluminio con varie tipologie di vetro: trasparente, satinato, opale, bronzo, reflex fumè e fumè.

I profili in alluminio sono volutamente ridotti per consentire la massima esaltazione del vetro; lo spessore di appena 40 mm consente estrema versatilità e conferisce al tempo stesso all'anta eccellenti caratteristiche di solidità.

Lo spessore del vetro varia da 5 a 6 mm a seconda della tipologia prescelta.

*Acqua is the sliding glass door available for Scigno Essential.*

*Acqua doors, with their slim and simple styling, have an aluminium frame that can contain transparent, opal, frosted, bronze, reflex smoked or fumè glass panels.*

*The aluminium profile bars have been deliberately reduced in size to allow the glass to be fully revealed to the greatest advantage, and the thickness of just 40 mm ensures great versatility combined with excellent strength and robustness.*

*Glass thickness varies from 5 to 6 mm depending on the type chosen.*

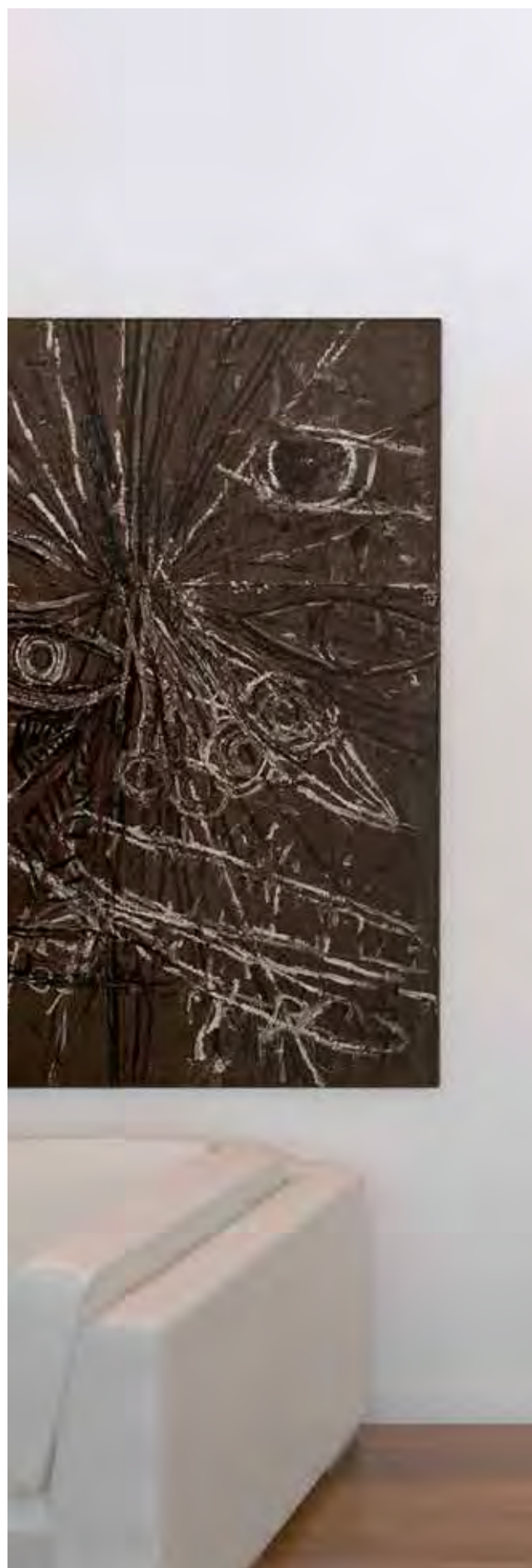

### Vetri - Glasses



### Profili in alluminio - Aluminium profiles





Essential scorrevole, anta Acqua vetro trasparente, maniglia A • *Essential sliding, Acqua clear glass door, handle A*



## Accessori e personalizzazioni

*Accessories and customization options*

- 88 Scrigno Slow Glass
- 89 Ammortizzatore per Essential Trial  
*Absorber for Essential Trial*
- 90 Scrigno Switch
- 91 Scrigno Open per Essential Pro  
*Scrigno Open for Essential Pro*
- 92 Ferramenta per porte in vetro Essential  
*Glass doors hardware for Essential*
- 93 Kit compensatori | Kit carter  
*Compensation kit | Kit cover*
- 94 Kit chiudiscrigno - Rotonda  
*Kit chiudiscrigno - Round*
- 94 Kit chiudiscrigno - Quadra  
*Kit chiudiscrigno - Square*
- 95 Kit chiudiscrigno - Segno  
*Kit chiudiscrigno - Sign*
- 96 Maniglie per porte scorrevoli  
*Handles for swing doors*
- 96 Kit chiudiscrigno per porte a Battente  
*Kit chiudiscrigno for swing doors*
- 97 Kit chiudiscrigno per porte in vetro  
*Handles for swing doors*
- 98 Maniglie per Essential Trial e Dual  
*Handles for Essential Trial and Dual*
- 99 Maniglie per Acqua  
*Handles for Acqua*
- 99 Serratura libero/occupato per Acqua  
*Bathroom door lock for Acqua*

# Accessori

## Accessories

### Scrigno Slow Glass

#### Scrigno Slow Glass



È l'innovativo sistema di rallentamento che permette una chiusura graduale e silenziosa della porta e del vetro.

Rallenta la corsa della porta nell'ultimo tratto di chiusura, evitando situazioni di pericolo.

E' completamente integrato all'interno della guida ed è testato per ante di peso massimo 60 kg.

Si può installare su tutta la gamma Essential compatibile, anche su soluzioni preesistenti.

*Slow Glass is an innovative slow closure system that allows glass doors to close gradually and silently.*

*The system slows door movement in the final part of closure, avoiding possible risks.*

*Completely concealed inside the track, the system is tested for doors weighing up to a maximum of 60 kg, and it can be fitted on all compatible Essential models, even if already installed.*



## Ammortizzatore per Essential Trial *Absorber for Essential Trial*

E' il sistema di rallentamento in chiusura appositamente studiato per Essential Trial.  
Rallenta la corsa dell'anta nell'ultimo tratto di chiusura, evitando situazioni di pericolo.

*A slow closure system designed specifically for Essential Trial.  
The system slows door movement in the final part of closure, avoiding possible risks.*



## Scugno Switch

### Scugno Switch

Composizione del kit - Composition of kit



- **n. 1 ricevitore radio** che può funzionare sia da interruttore (on/off) sia in modo impulsivo (per essere integrato in un impianto a relè). Il carico massimo che può supportare è di 1.000W di potenza; la trasmissione è sicura in quanto si utilizza la banda di frequenza a 868 Mhz.
- **n. 1 pulsante** trasmettitore a due canali completo di placca. I due canali possono essere programmati in modo uguale o diverso nel caso il ricevitore sia settato nella modalità interruttore on/off. La placca consente di completare il montaggio in tutte quelle situazioni in cui non ci sono particolari esigenze estetiche di abbinamento con altri interruttori tradizionali già presenti nell'abitazione. Trasmettitore e placca sono disponibili nella variante bianco e grigio antracite.
- **n. 1 kit di 5 adattatori** che servono per utilizzare le placche standard più comunemente diffuse e che si trovano facilmente in commercio. Questo permette di montare sull'interruttore in radiofrequenza le stesse placche degli interruttori cablati tradizionali. Il kit è disponibile nella versione bianco o grigio antracite.

- *1 radio receiver that can operate as a simple ON/OFF switch or with impulses (for integration in a relay system). The maximum power that can be controlled is 1000W, and transmission is safe and secure because the 868MHz frequency band is used.*
- *1 two-channel transmitter button complete with surround. The two channels can both be programmed in the same way or separately if the receiver is set for operation as an ON/OFF switch. The surround allows installation to be completed in all spaces where there is no particular need to match other conventional light switches that may be already present nearby. The transmitter button and surround are available in white and anthracite grey versions.*
- *1 kit of 5 adaptors to allow the standard surrounds that are most widespread and commonly available on the market to be used, making it possible to fit the radiofrequency switch with a surround of the same style as other nearby light switches with conventional wiring. The kit is available in white and anthracite grey versions.*

## Vantaggi | Advantages

- Facile da installare;
- perfetta armonizzazione estetica con gli impianti già presenti nell'abitazione attraverso l'utilizzo del kit di adattatori;
- utilizzo di batterie a bottone al litio a lunga durata;
- Conforme a:
  - Direttiva 89/336/CEE relativa alla compatibilità elettromagnetica
  - Direttiva 73/23/CEE relativa alle apparecchiature elettriche in bassa tensione.
  - Direttiva 1999/5/CE riguardante le apparecchiature radio e le apparecchiature terminali di telecomunicazione e il reciproco riconoscimento della loro conformità.
- *Easy to install;*
- *styling and colour to perfectly match existing switch and socket fittings with use of the adaptor kit;*
- *powered by long-life lithium button batteries;*
- *In accordance with:*
  - *Directive 89/336/EEC (ECM Directives) and subsequent amendments concerning Electromagnetic Compatibility*
  - *Directive 73/23/EEC concerning Low Voltage Equipment.*
  - *Directive 99/5/EC in accordance with the Radio & Telecommunication Terminal Equipment and the mutual recognition of their conformity.*

### Scrigno Open per Essential Pro *Scrigno Open for Essential Pro*

Dalla sinergia tra Scrigno e Faac, azienda leader nelle automazioni in ambito residenziale e industriale, nasce OPEN, il dispositivo che consente di rendere automatica l'apertura e la chiusura di una porta scorrevole a scomparsa, per il controtelaio ESSENTIAL PRO.

È un kit di semplice installazione e può essere applicato anche su porte scorrevoli a scomparsa già in opera, senza ulteriori lavori di muratura.

Di dimensioni contenute, il gruppo motore è fissato alla guida del controtelaio e si cela totalmente mantenendo inalterata l'estetica della porta.

L'automazione funziona nelle seguenti modalità:

#### Modalità Automatica

La porta si apre e si chiude in automatico dopo un tempo di pausa programmato (da 1 a 20 secondi).

Tale comando può essere fornito tramite:

- pulsante in radiofrequenza
- pulsante cablato (non fornito)
- radar (optional).

#### Modalità Push&Go

Permette un'apertura o una chiusura prima del tempo pausa, semplicemente con una leggera spinta della mano. Questa modalità può essere scelta senza collegamento di altri dispositivi di comando quali radar, pulsanti o riceventi.

#### Modalità Manuale

Viene attivata attraverso il comando "fermo" sull'interruttore. Quando viene rilasciato il comando "fermo", la porta ritorna in funzionamento automatico.

- L'installazione del Kit Open riduce la luce di passaggio in larghezza di circa 80 mm.
- Il kit permette l'automazione di porte con peso massimo di 40 Kg.

*OPEN, a device that makes it possible to automatically open and close a sliding disappearing door mounted on a ESSENTIAL PRO frame, is the fruit of collaboration between Scrigno and Faac, a leader in the field of home and industrial automation.*

*Available in kit form, it is easy to fit, even in the case of sliding disappearing doors already installed, with no need for additional building work.*

*The compact motor unit is fixed to the track at the top of the frame and is totally concealed, leaving the external appearance of the door unchanged.*

*The automatic system works in the following modes:*

#### **Automatic mode**

*The door opens and closes automatically after a programmed interval (from 1 to 20 seconds).*

*The command can be provided by:*

- a radiofrequency button
- a wired button (not supplied)
- radar (optional).



#### **Push&Go mode**

*Allows the door to be opened or closed before the programmed interval simply with a slight pressure of the hand. This operation mode can be chosen without connecting any other command devices, such as a radar system, buttons or receivers.*

#### **Manual mode**

*This operating mode is activated with the "Stop" command on the switch.*

*When the "Stop" command is released, the door returns to automatic operation.*

- *The installation of the Open kit reduces the passage opening in width of 80 mm approximately.*

- *The kit allows the automation of doors for a maximum weight of 40 Kg.*

# Accessori

## Accessories

Per il controtelaio Essential, Scigno fornisce il necessario per l'installazione dell'anta in vetro, i cui componenti (l'anta, la ferramenta e gli stipiti) possono essere acquistati separatamente. Solo l'utilizzo di tutti i componenti offerti garantisce il miglior risultato estetico.

La porta completa si compone quindi dei seguenti elementi:  
KIT PINZE, CARTER, KIT COMPENSATORI, VETRO, eventuali ACCESSORI.

*For frame system Essential, Scigno supplies the required components for the installation of a glass door (door panel, hardware and jambs). Such components could be purchased separately. Only the installation of all components offered guarantees the best appearance result.*

*The complete door consists therefore in the following components:  
CLAMP KIT, PROTECTION COVER, COMPENSATION PROFILE KIT, GLASS PANEL, and any necessary ACCESSORIES.*

## Ferramenta per porte in vetro Essential

### Glass doors hardware Essential



Pinze per anta vetro  
Clamps for glass door

Il kit ferramenta per ante in vetro è un accessorio utilizzabile per i controtelai Essential anta singola e anta doppia.

Consente l'installazione di una lasta vetro di spessore variabile (8 o 10 mm).

È possibile prevedere l'installazione di uno stipite in legno o in alluminio, garantendo la totale scomparsa delle pinze, per una estetica estremamente elegante e pulita. Le pinze, adottando un sistema evoluto a pressione, non prevedono alcuna foratura sulla lastra.

È infine abbinabile al sistema di rallentamento in chiusura Slow Glass.

Per la doppia anta sono necessari 2 kit.  
Peso massimo vetro 120 Kg.

*The glass door hardware kit can be used for Essential frames with single and double doors, and allows the installation of glass panels with a thickness of 8 or 10 mm. A doorpost in wood or aluminium can also be fitted, guaranteeing the total disappearance of the glass clamps, for an extremely clean and elegant visual appearance. The glass clamps use an advanced system to grip the glass, eliminating the need for holes to be drilled.*

*The kit can also be combined with the Slow Glass system for slow closure of the doors.*

*2 kits are needed for double doors.  
Maximum glass weight 120 kg.*

Kit compensatori singoli • *Compensation kit simple*



Kit compensatori doppi • *Compensation kit double*



## Kit compensatori

### *Compensation kit*

Sono specifici elementi verticali appositamente studiati per ridurre la luce interna del cassonetto e del montante di battuta allo spessore del vetro.

Una volta installati possono essere verniciati per un perfetto effetto a scomparsa.

*These are specific vertical elements designed to reduce the internal opening size of the metal box and the closure upright to the glass thickness. After installation, the elements can be painted to create a perfectly invisible effect*



## kit carter

### *Kit cover*

Il carter di copertura è fornibile in due finiture, alluminio anodizzato e simil inox.

Tutti i componenti sono vendibili separatamente. L'anta in vetro è realizzabile al centimetro.

*The protection cover is available in anodized aluminium or stainless steel effect finishes.*

*All components can be sold separately. Glass doors are available in sizes varying in steps of 1 cm.*

Kit Chiudiscrigno è la maniglia per le porte scorrevoli Scrigno in legno; permette di far scomparire completamente la porta.

È disponibile sia per porte scorrevoli ad anta unica sia ad anta doppia, nella versione con serratura, senza serratura, con serratura con chiave pieghevole e con foro a cilindro europeo.

Quattro sono le finiture: oro lucido, oro satinato, cromo lucido e cromo satinato.

La versione quadra è disponibile nella finitura cromo satinato.

Scrigno offers appropriate door handles and locks for wooden sliding doors. The "Kit Chiudiscrigno" allows the door to disappear completely with no protrusions into the opening space. Available in 4 finishes: polished brass, satin brass, polished chrome, satin chrome and rhodium chrome.

















"Kit Chiudiscrigno" is available to lock with turn and emergency release, hinged "lever type" key, euro profile cylinder mechanism or only with flush pull handles.

End pulls are also supplied.

The Square handles are available in 1 finishe satin rhodium.

## Kit Chiudiscrigno - Rotonda

### Kit chiudiscrigno - Round

	Maniglia senza serratura Handles without lock	Maniglia con serratura Handle with lock	Maniglia con chiave pieghevole Handle with folding key	Maniglia con foro a cilindro europeo Handle with hole for european profile cylinder
Cromo Lucido Polished chrome				
Cromo Satinato Satin chrome				
Oro Lucido Polished brass				
Oro Satinato Satin brass				

## Kit Chiudiscrigno - Quadra

### Kit chiudiscrigno - Square

	Maniglia senza serratura Handles without lock	Maniglia con serratura Handle with lock	Maniglia con foro a cilindro europeo Handle with hole for european profile cylinder	Maniglia con chiave pieghevole Handle with folding key
Cromo Satinato Satin chrome				

### Kit Chiudiscrigno - Segno

#### *Kit chiudiscrigno - Sign*

Scrigno amplia la propria gamma di maniglie per porte scorrevoli Essential in legno proponendo Kit Chiudiscrigno Segno, una soluzione dal design innovativo.

Si tratta di una serie di maniglie magnetiche ad incasso, perfettamente a filo dell'anta, con meccanismo Apri e Chiudi a levitazione magnetica, studiato per durare nel tempo.

Kit Chiudiscrigno Segno è disponibile nella versione tonda, quadra e rettangolare, con e senza serratura nelle finiture cromo satinato e cromo lucido.

Scrigno now extends its range of handles for Essential sliding wooden doors with the Segno Chiudiscrigno Kit, a solution featuring innovative design.

The range includes a series of inset magnetic handles that are perfectly flush with the door, with a magnetic Opening and Closure mechanism designed to give many years of service.

The Segno Chiudiscrigno Kit is available in round, square and rectangular versions, with or without a lock and finished in satin or polished chrome.



Maniglia tonda magnetica\*  
senza serratura  
*Magnetic round  
handles without lock*



Maniglia tonda magnetica\*  
con serratura  
*Magnetic round  
handles with lock*



Maniglia quadra magnetica\*  
senza serratura  
*Magnetic square  
handles without lock*



Maniglia quadra magnetica\*  
con serratura  
*Magnetic square  
handles with lock*



Maniglia rettangolare  
magnetica\* senza serratura  
*Magnetic\* rectangular  
handles without lock*



Maniglia rettangolare  
magnetica\* con serratura  
*Magnetic\* rectangular  
handles with lock*

\* Meccanismo Apri e Chiudi a levitazione magnetica • *Magnetic Opening and Closure mechanism.*

# Accessori

---

## Accessories

### Maniglie per porte scorrevoli

*Handles for swing doors*



Maniglia Vaschetta  
*Handle Flush Pull*



Maniglia ricavata  
*Integrated handle*

### Kit chiudiscrigno per porte a Battente

*Kit chiudiscrigno for swing doors*

Scrigno propone una maniglia con finitura cromo satinato il cui kit comprende:  
maniglia più borchia con foro chiave o cilindro europeo.

*Scrigno offers a handle with a satin chrome in a kit that includes: a handle with escutcheon with a hole for a key or a european lock.*



Maniglia cromo satinato  
*Satin chrome handle*

## Kit chiudiscrigno per porte in vetro

### *Kit chiudiscrigno for glass doors*

Scrigno propone una ampia gamma di maniglie per le proprie soluzioni vetro, diversificabili per misura e finitura. Quattro modelli per soddisfare ogni esigenza estetica e funzionale.

- TUBE (disponibile in tre misure, h. 300 - 500 - 800)
- QUADRA (disponibile in due misure, h. 310 - 460)
- GHOST (non prevede fori sul vetro)
- MODELLO A (non prevede fori sul vetro).

*Scrigno offers a wide range of handles for its glass doors, with different sizes and finishes. Four models to satisfy all needs of design and functionality.*

- TUBE (available in three sizes, h. 300 - 500 - 800)
- QUADRA (available in two sizes, h. 310 - 460)
- GHOST (no holes needed in the glass)
- MODELLO A (no holes needed in the glass).

Soluzione senza foratura sul vetro • *No holes needed in the glass*

Tube



Quadra



Ghost

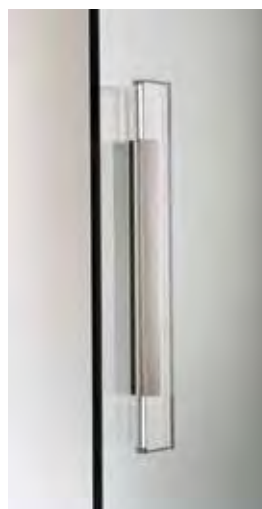

Modello A



## Maniglie per Essential Trial *Handles for Essential Trial*



Coppia maniglia più rondella  
Art. 32420 + 32421  
*Pair of handles plus washer*  
Art. 32420 + 32421



Maniglia a scomparsa  
senza serratura  
*Concealed handle without lock*

## Maniglie per Essential Dual *Handles for Essential Dual*



Maniglione  
*Upright handle*



Disco 80  
*Ring handle*

### Maniglia per Acqua

#### *Handles for Acqua*

Finiture disponibili colore: argento, bianco e marrone.  
*Finishes availables: silver-colored, white and brown.*

Modello A



Modello B



Modello C



### Serratura libero/occupato per Acqua

#### *Bathroom door lock for Acqua*

Finiture disponibili colore: argento, bianco e marrone. Finitura nottolino e piastra serratura: cromo satinato.  
*Finishes availables: silver-colored, white and brown. Turnsnib and escutcheon plate finished in satin chrome.*





# ESSENTIAL<sup>®</sup>

by SCRIGNO<sup>®</sup>

Dettagli tecnici controtelai  
*Technical details frames*

- 102 Essential Scorrevole | *Essential Sliding*
- 106 Essential Scorrevole 145 | *Essential Sliding 145*
- 110 Essential Pro
- 114 Essential Scorrevole EI 30 | *Sliding EI 30*
- 118 Essential: soluzione doccia  
*Essential: the shower solution*
- 120 Essential Trial
- 124 Essential Dual
- 126 Essential Battente | *Essential Swing*
- 128 Essential Battente Senza Traverso  
*Essential Swing Without Upper Crosspiece*
- 129 Essential Battente Trapezoidale  
*Essential Swing Trapezoidal Shape*
- 132 Essential Battente EI 30/60 | *Essential Swing EI 30/60*
- 138 Essential Battente Zero | *Essential Swing Zero*
- 140 Essential Little  
*Essential Little*
- 144 Essential Little Zero  
*Essential Little Zero*
- 146 Essential Little Cartongesso  
*Essential Little Plasterboard*
- 160 Dettagli tecnici porte  
*Technical details doors*

# Essential scorrevole singolo

## Essential sliding single

Intonaco  
Plastered

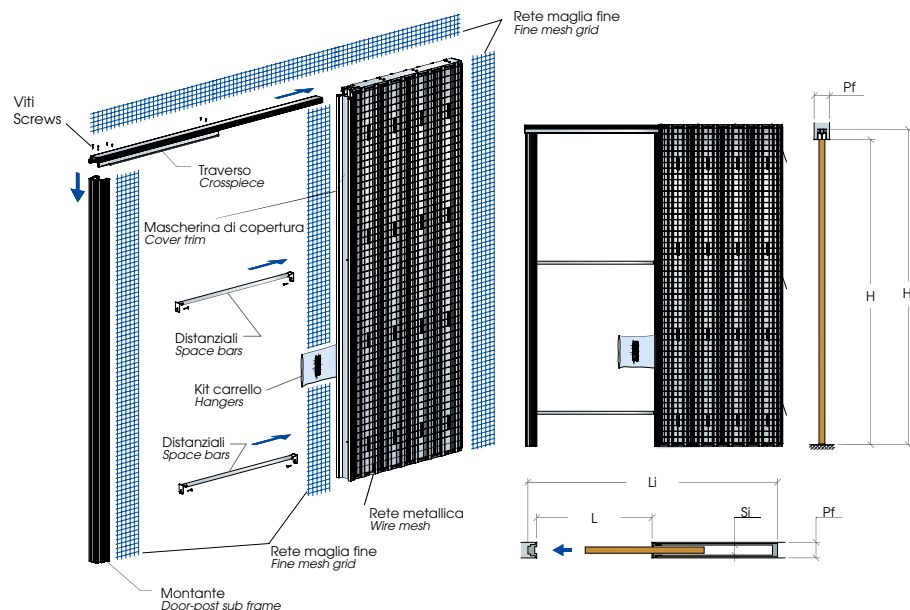

### Standard Standard

Legenda  
Legend

- L = Larghezza luce  
Opening Width
- H = Altezza luce  
Opening Height
- Li = Ingombro in larghezza  
Overall Width
- Hi = Ingombro in altezza  
Overall Height
- Pf = Parete finita  
Finished Wall
- Si = Sede interna  
Internal Space

Luce di passaggio Clear opening size		Misura d'ingombro Structural opening size		Parete finita/Sede interna Finished wall/Internal space
L	H	Li	Hi	Pf / Si
600	2000/2100	1320	2065/2165	105/69 - 125/89
700		1520		
800		1720		
900		1920		
1000		2120		
1100		2320		
1200		2520		
				105/69
				105/69 - 125/89

### Fuori misura

#### Extra Height

Luce di passaggio Clear opening size		Misura d'ingombro Structural opening size		Parete finita Sede interna Finished wall Internal space	Luce di passaggio Clear opening size		Misura d'ingombro Structural opening size		Parete finita Sede interna Finished wall Internal space
L	H	Li	Hi	Pf / Si	L	H	Li	Hi	Pf / Si
600	800÷1990 2010÷2090	1320	865÷2055 2075÷2155	105/69 - 125/89	600	2110÷2700	1320	2175÷2765	105/69 - 125/89
700		1520							
800		1720							
900		1920							
1000		2120							
1100		2320							
1200		2520							

Prima di ordinare la porta per il controtelesia Essential è necessario verificare in cantiere l'effettiva misura della luce di passaggio. Essa si rileva ad installazione avvenuta del controtelesia. La luce di passaggio effettiva è ridotta in larghezza di 10 mm.

Before ordering the door for the Essential frame, the effective clear opening size must be checked onsite. This must be measured after the installation of the frame. The effective clear opening size is reduced in width by 10 mm.

# Essential scorrevole singolo

## Essential sliding single

Cartongesso  
Plasterboard

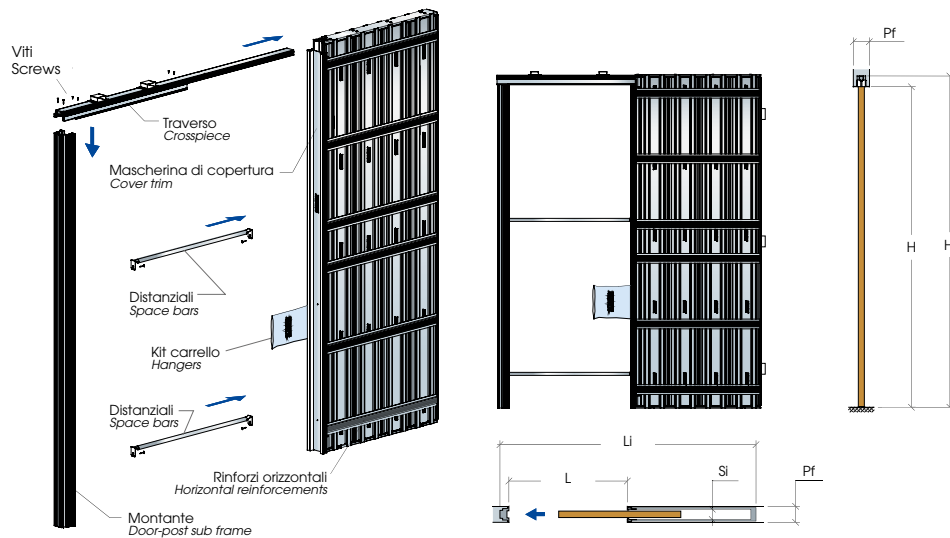

### Standard Standard

Luce di passaggio Clear opening size		Misura d'ingombro Structural opening size		Parete finita/Sede interna Finished wall/Internal space
L	H	Li	Hi	Pf / Si
600	2000/2100	1320	2065/2165	100/54 - 125/69
700		1520		100/54 - 125/69
750		1620		125/69
800		1720		100/54 - 125/69
900		1920		100/54 - 125/69
1000		2120		125/69
1100		2320		125/69
1200		2520		125/69

Legenda  
Legend

L = Larghezza luce  
Opening Width  
H = Altezza luce  
Opening Height  
Li = Ingombro in larghezza  
Overall Width  
Hi = Ingombro in altezza  
Overall Height  
Pf = Parete finita  
Finished Wall  
Si = Sede interna  
Internal Space

### Fuori misura Extra Height

Luce di passaggio Clear opening size		Misura d'ingombro Structural opening size		Parete finita Sede interna Finished wall Internal space	Luce di passaggio Clear opening size		Misura d'ingombro Structural opening size		Parete finita Sede interna Finished wall Internal space
L	H	Li	Hi	Pf / Si	L	H	Li	Hi	Pf / Si
600	800÷1990 2010÷2090	1320	865÷2055 2075÷2155	100/54 - 125/69	600	2110÷2400	1320	2175÷2465	125/69
700		1520			700		1520		
800		1720			800		1720		
900		1920			900		1920		
1000		2120		1000	2120				
1100		2320		1100	2320				
1200		2520		1200	2520				

Prima di ordinare la porta per il controtelaio Essential è necessario verificare in cantiere l'effettiva misura della luce di passaggio. Essa si rileva ad installazione avvenuta del controtelaio. La luce di passaggio effettiva è ridotta in larghezza di 10 mm.

Before ordering the door for the Essential frame, the effective clear opening size must be checked onsite. This must be measured after the installation of the frame. The effective clear opening size is reduced in width by 10 mm.

# Essential scorrevole doppio

## Essential sliding double

Intonaco  
Plastered

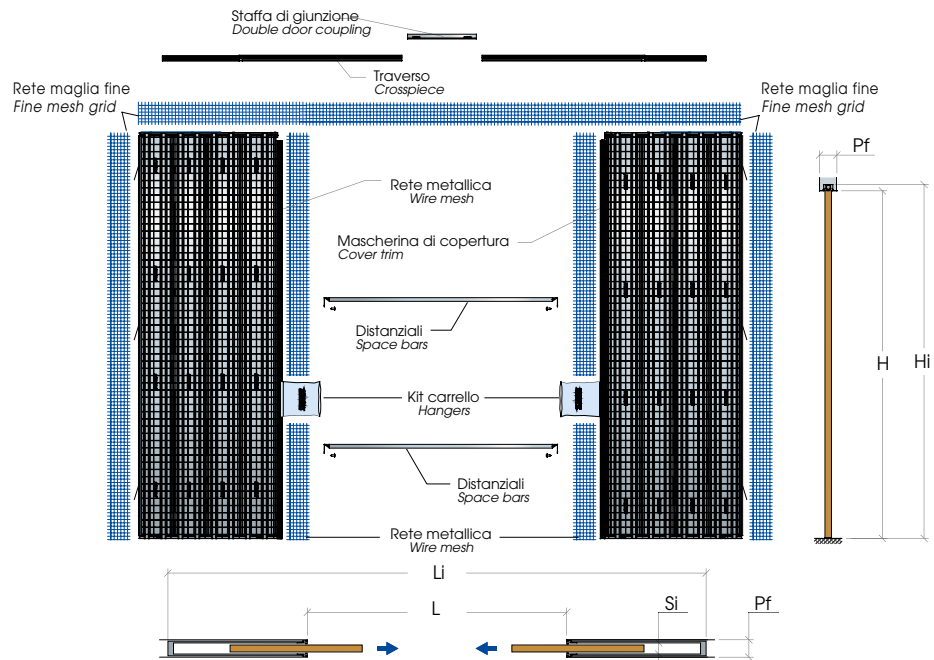

### Standard Standard

Legenda  
Legend

- L = Larghezza luce  
Opening Width
- H = Altezza luce  
Opening Height
- Li = Ingombro in larghezza  
Overall Width
- Hi = Ingombro in altezza  
Overall Height
- Pf = Parete finita  
Finished Wall
- Si = Sede interna  
Internal Space

Luce di passaggio Clear opening size		Misura d'ingombro Structural opening size		Parete finita/Sede interna Finished wall/Internal space
L	H	Li	Hi	Pf / Si
1200		2520		
1400		2920		
1600		3320		
1800	2000/2100	3720	2065/2165	105/69 - 125/89
2000		4120		
2200		4520		
2400		4920		

### Fuori misura Extra Height

Luce di passaggio Clear opening size		Misura d'ingombro Structural opening size		Parete finita Sede interna Finished wall Internal space	Luce di passaggio Clear opening size		Misura d'ingombro Structural opening size		Parete finita Sede interna Finished wall Internal space
L	H	Li	Hi	Pf / Si	L	H	Li	Hi	Pf / Si
1200		2520			1200		2520		
1400		2920			1400		2920		
1600		3320			1600		3320		
1800	800÷1990 2010÷2090	3720	865÷2055 2075÷2155	105/69 - 125/89	1800	2110÷2700	3720	2175÷2765	105/69 - 125/89
2000		4120			2000		4120		
2200		4520			2200		4520		
2400		4920			2400		4920		

Prima di ordinare la porta per il controllo Essential è necessario verificare in cantiere l'effettiva misura della luce di passaggio. Essa si rileva ad installazione avvenuta del controllo. La luce di passaggio effettiva è ridotta in larghezza di 10 mm.

Before ordering the door for the Essential frame, the effective clear opening size must be checked onsite. This must be measured after the installation of the frame. The effective clear opening size is reduced in width by 10 mm.

# Essential scorrevole doppio

## Essential sliding double

Cartongesso  
Plasterboard

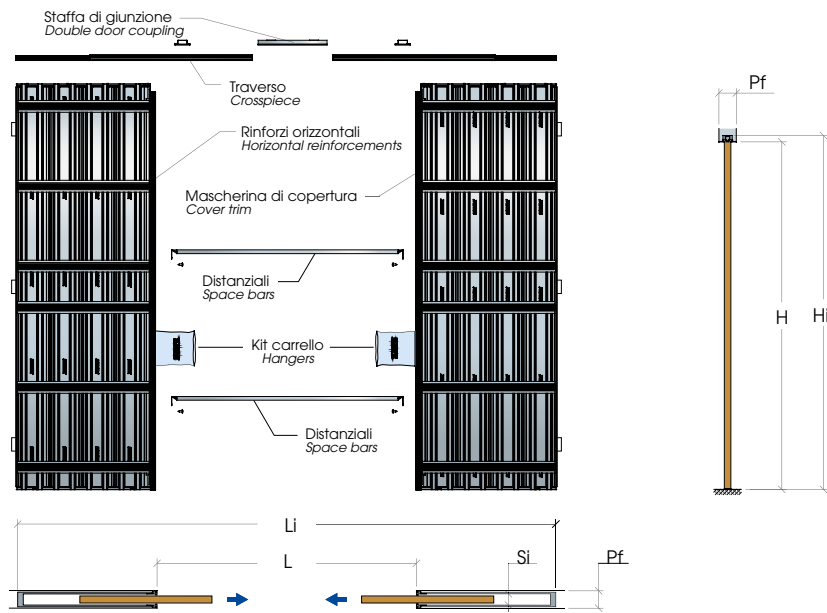

Standard  
Standard

Luce di passaggio Clear opening size		Misura d'ingombro Structural opening size		Parete finita/Sede interna Finished wall/Internal space
L	H	Li	Hi	Pf / Si
1200	2000/2100	2520	2065/2165	100/54 - 125/69
1400		2920		
1600		3320		
1800		3720		
2000		4120		
2200		4520		
2400		4920		125/69

Legenda  
Legend

L = Larghezza luce  
Opening Width  
H = Altezza luce  
Opening Height  
Li = Ingombro in larghezza  
Overall Width  
Hi = Ingombro in altezza  
Overall Height  
Pf = Parete finita  
Finished Wall  
Si = Sede interna  
Internal Space

Fuori misura  
Extra Height

Luce di passaggio Clear opening size		Misura d'ingombro Structural opening size		Parete finita Sede interna Finished wall Internal space	Luce di passaggio Clear opening size		Misura d'ingombro Structural opening size		Parete finita Sede interna Finished wall Internal space
L	H	Li	Hi	Pf / Si	L	H	Li	Hi	Pf / Si
1200	800÷1990 2010÷2090	2520	865÷2055 2075÷2155	100/54 - 125/69	1200	2110÷2400	2520	2175÷2465	125/69
1400		2920							
1600		3320							
1800		3720							
2000		4120							
2200		4520							
2400		4920		125/69					

Prima di ordinare la porta per il controtelaio Essential è necessario verificare in cantiere l'effettiva misura della luce di passaggio. Essa si rileva ad installazione avvenuta del controtelaio. La luce di passaggio effettiva è ridotta in larghezza di 10 mm.

Before ordering the door for the Essential frame, the effective clear opening size must be checked onsite. This must be measured after the installation of the frame. The effective clear opening size is reduced in width by 10 mm.

# Essential scorrevole 145 singolo

## Essential sliding 145 single

Intonaco  
Plastered

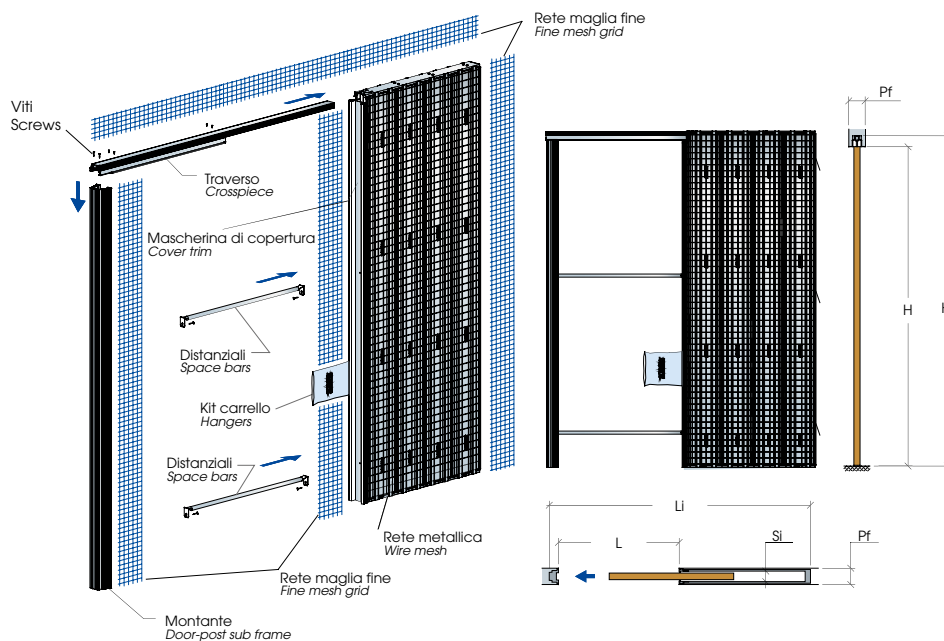

### Standard Standard

#### Legenda Legend

- L = Larghezza luce  
Opening Width
- H = Altezza luce  
Opening Height
- Li = Ingombro in larghezza  
Overall Width
- Hi = Ingombro in altezza  
Overall Height
- Pf = Parete finita  
Finished Wall
- Si = Sede interna  
Internal Space

Luce di passaggio Clear opening size		Misura d'ingombro Structural opening size		Parete finita/Sede interna Finished wall/Internal space
L	H	Li	Hi	Pf / Si
600	1800÷2700	1320	1865÷2765	145 - 89
700		1520		
750		1620		
800		1720		
900		1920		
1000		2120		
1100		2320		
1200		2520		

Prima di ordinare la porta per il controtelaio Essential è necessario verificare in cantiere l'effettiva misura della luce di passaggio. Essa si rileva ad installazione avvenuta del controtelaio. La luce di passaggio effettiva è ridotta in larghezza di 10 mm.

Before ordering the door for the Essential frame, the effective clear opening size must be checked onsite. This must be measured after the installation of the frame. The effective clear opening size is reduced in width by 10 mm.

# Essential scorrevole 145 doppio

## Essential sliding 145 double

Intonaco  
Plastered

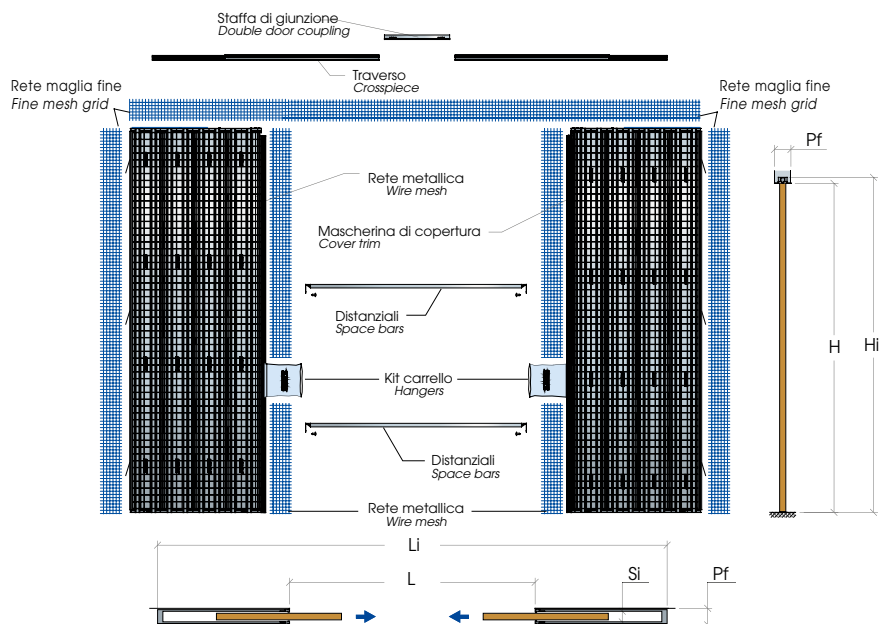

Standard  
Standard

Luce di passaggio Clear opening size		Misura d'ingombro Structural opening size		Parete finita/Sede interna Finished wall/Internal space
L	H	Li	Hi	Pf / Si
1200	1800÷2700	2620	1865÷2765	145 - 89
1400		2920		
1600		3320		
1800		3720		
2000		4120		
2200		4520		
2400		4920		

Legenda  
Legend

L = Larghezza luce  
Opening Width  
H = Altezza luce  
Opening Height  
Li = Ingombro in larghezza  
Overall Width  
Hi = Ingombro in altezza  
Overall Height  
Pf = Parete finita  
Finished Wall  
Si = Sede interna  
Internal Space

Prima di ordinare la porta per il controtelaio Essential è necessario verificare in cantiere l'effettiva misura della luce di passaggio. Essa si rileva ad installazione avvenuta del controtelaio. La luce di passaggio effettiva è ridotta in larghezza di 10 mm.

Before ordering the door for the Essential frame, the effective clear opening size must be checked onsite. This must be measured after the installation of the frame. The effective clear opening size is reduced in width by 10 mm.

# Essential scorrevole

## Essential sliding single

Controtelaio per porta scorrevole a scomparsa senza stipite per parete in muratura da 105/125/145 mm  
 Frame for sliding disappearing door without doorpost for masonry walls with thicknesses 105/125/145 mm.

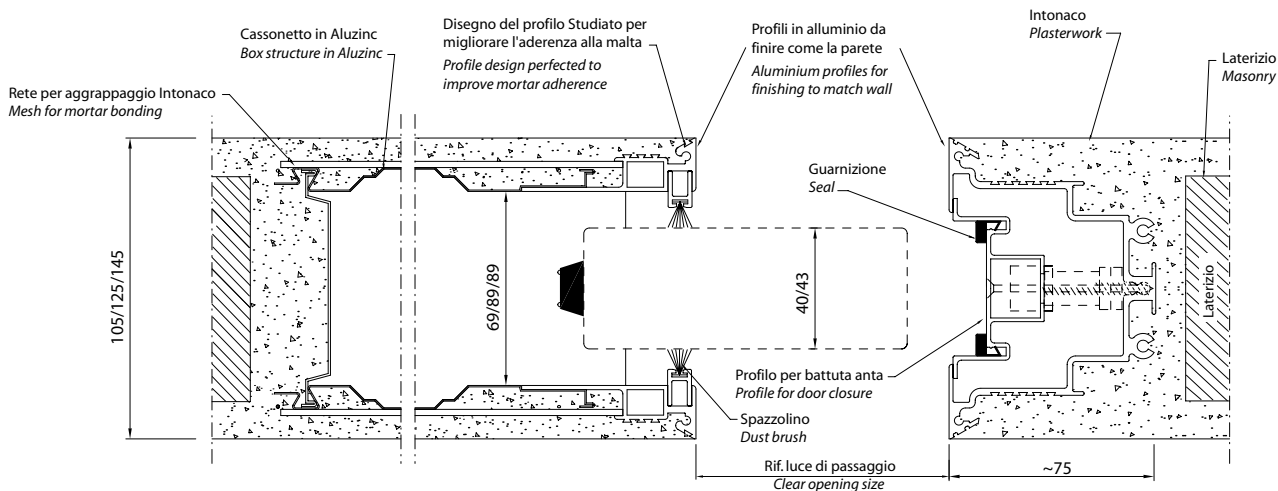

Controtelaio per porta scorrevole a scomparsa senza stipite per parete in Cartongesso da 100 mm e 125 mm.  
 Frame for sliding disappearing door without doorpost for plasterboard walls with thicknesses 100 mm and 125 mm

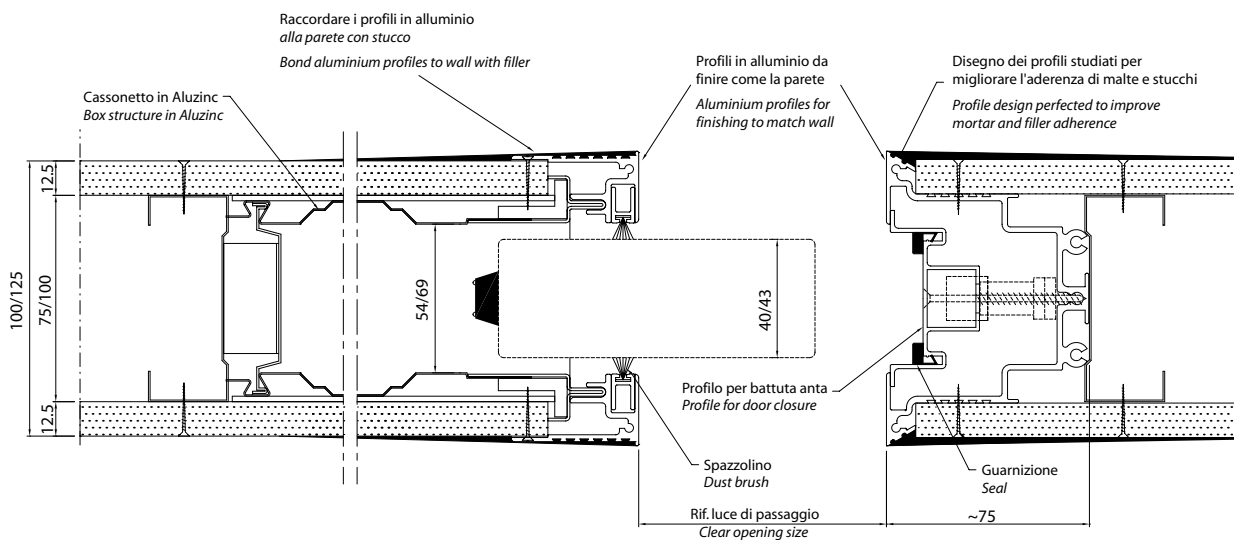

\* Per parete 100 mm spessore porta massimo 40 mm / Maximum door thickness 40 mm for 100 mm wall thickness

Parete in muratura da 105/125/145 mm  
 Masonry walls with thicknesses 105/125/145 mm

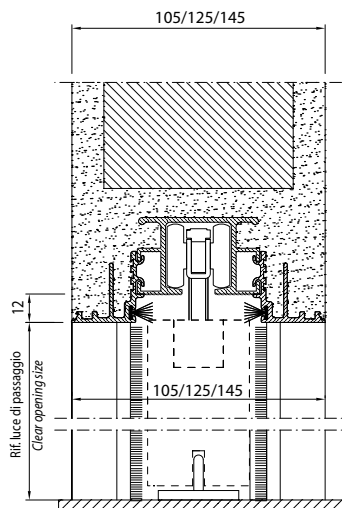

Parete in Cartongesso da 100 mm e 125 mm  
 Plasterboard walls with thicknesses 100 mm and 125 mm

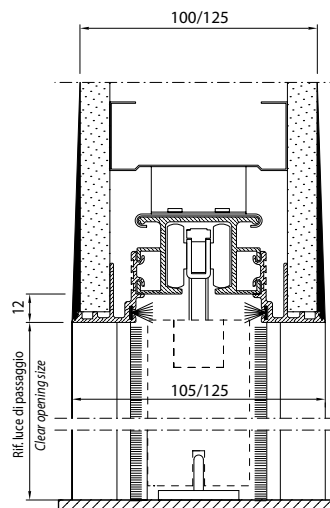



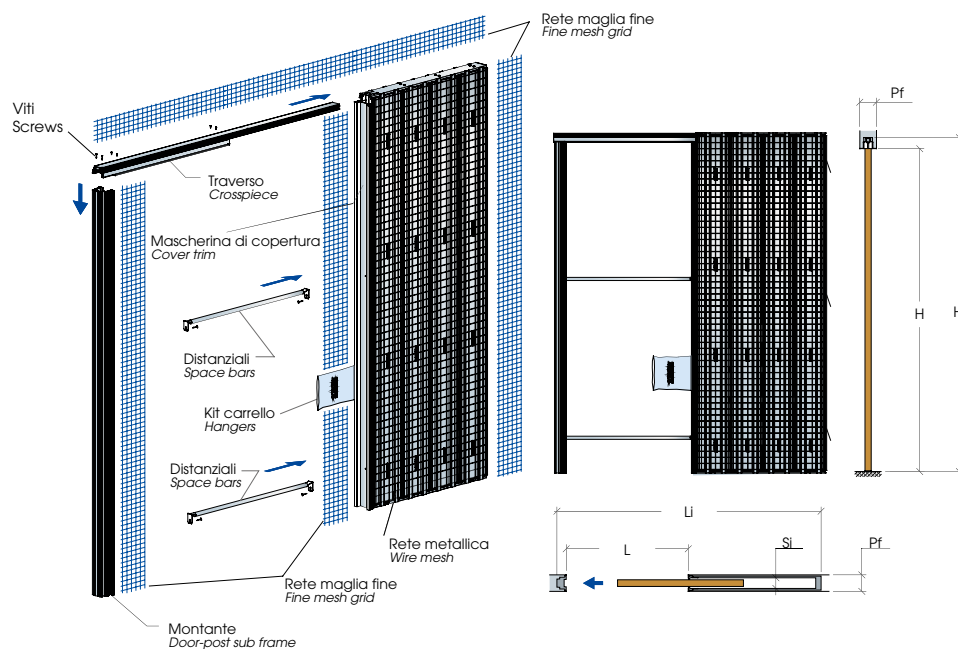

## Standard Standard

### Legenda Legend

- L = Larghezza luce  
Opening Width
- H = Altezza luce  
Opening Height
- Li = Ingombro in larghezza  
Overall Width
- Hi = Ingombro in altezza  
Overall Height
- Pf = Parete finita  
Finished Wall
- Si = Sede interna  
Internal Space

Luce di passaggio Clear opening size		Misura d'ingombro Structural opening size		Pared acabada /Hueco interior
L	H	Li	Hi	Pf / Si
600	2000/2100	1320	2105/2205	105 / 69
700		1520		
800		1720		
900		1920		
1000		2120		
1100		2320		
1200		2520		

La luce di passaggio effettiva è ridotta in larghezza di 10 mm. - The effective clear opening size is reduced in width by 10 mm for the Single door.

Essential Pro per Intonaco consente l'installazione di un pannello porta con spessore massimo 43 mm.

Essential Pro for plasterwork allows a door panel with a maximum thickness of 43 mm to be installed.

#### Dotazione di serie:

- carrelli portata kg 120 per anta
- battuta anteriore in alluminio grezzo da tinggiare
- guarnizione e spazzolini parapolvere

#### Standard accessories:

- hangers with a capacity of 120 kg for every panel
- front upright in unfinished aluminium to be painted
- sealing strip and anti-dust brushes

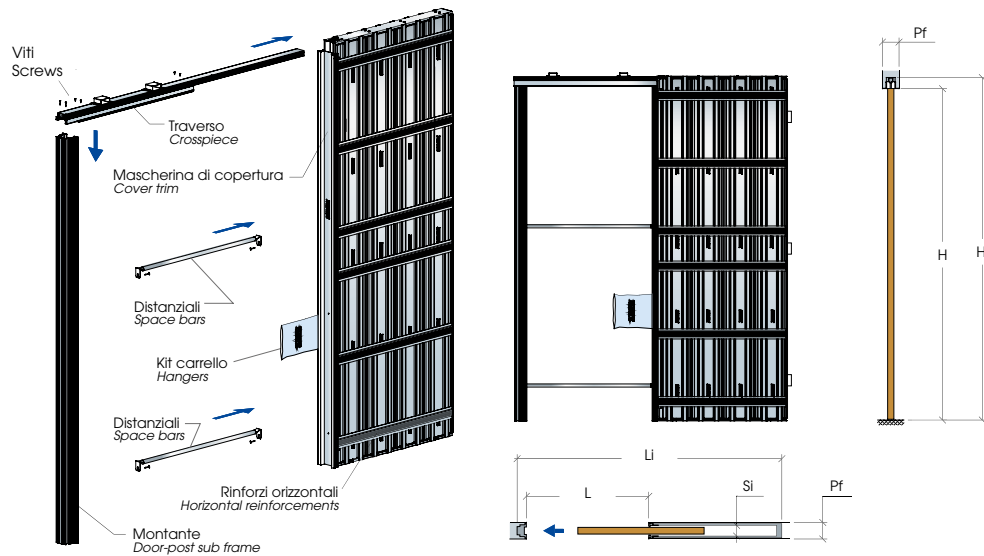

## Standard Standard

Luce di passaggio Clear opening size		Misura d'ingombro Structural opening size		Parete finita/Sede interna Finished wall/Internal space
L	H	Li	Hi	Pf / Si
600	2000/2100	1320	2105/2205	100 / 54
700		1520		
800		1720		
900		1920		
1000		2120		

### Legenda Legend

- L = Larghezza luce  
Opening Width
- H = Altezza luce  
Opening Height
- Li = Ingombro in larghezza  
Overall Width
- Hi = Ingombro in altezza  
Overall Height
- Pf = Parete finita  
Finished Wall
- Si = Sede interna  
Internal Space

La luce di passaggio effettiva è ridotta in larghezza di 10 mm. - *The effective clear opening size is reduced in width by 10 mm for the Single door.*

Essential Pro per Cartongesso consente l'installazione di un pannello porta con spessore massimo 40 mm. I profili in alluminio che delimitano la luce di passaggio, sia in larghezza sia in altezza, per la parete finita 100 mm, hanno uno spessore pari a 105 mm e devono essere raccordati alla parete mediante rasatura.

#### Dotazione di serie:

- carrelli portata kg 120 per anta
- battuta anteriore in alluminio grezzo da tinteggiare
- guarnizione e spazzolini parapolvere

I controlelai per Cartongesso sono predisposti per lastre dello spessore di 12,5 mm per lato.

*Essential Pro for plasterboard allows a door panel with a maximum thickness of 40 mm to be installed. The profile bars around the top and sides of the door opening, for a finished wall thickness of 100 mm, have a thickness of 105 mm, and the gaps must be smoothed with finishing plaster.*

#### Standard accessories:

- hangers with a capacity of 120 kg for every panel
- front upright in unfinished aluminium to be painted
- sealing strip and anti-dust brushes

*Sliding door frames for plasterboard are designed for plasterboard panels with a thickness of 12.5 mm on each side.*

Controtelaio per anta scorrevole a scomparsa senza stipite per parete in muratura da 105 mm  
 Frame for sliding disappearing door without doorpost for masonry walls thickness 105 mm

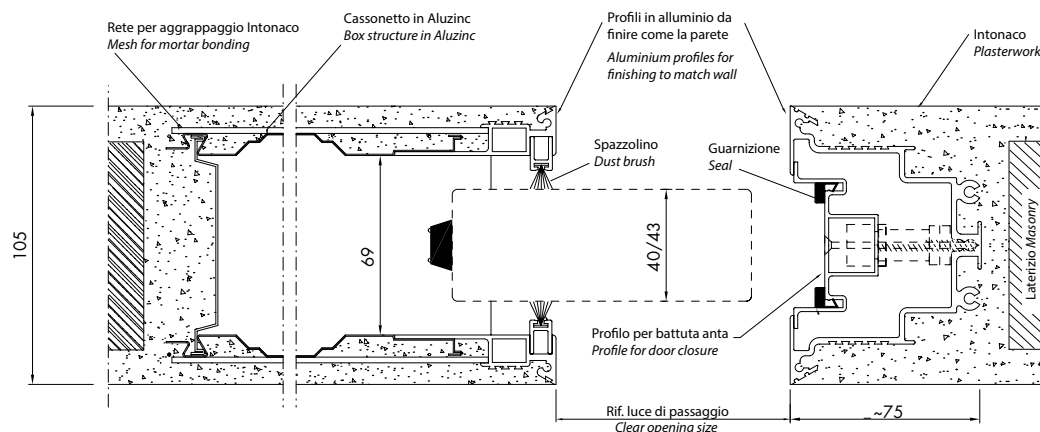

Controtelaio per anta scorrevole a scomparsa senza stipite per parete in Cartongesso da 100 mm  
 Frame for sliding disappearing door without doorpost for plasterboard walls thickness 100 mm

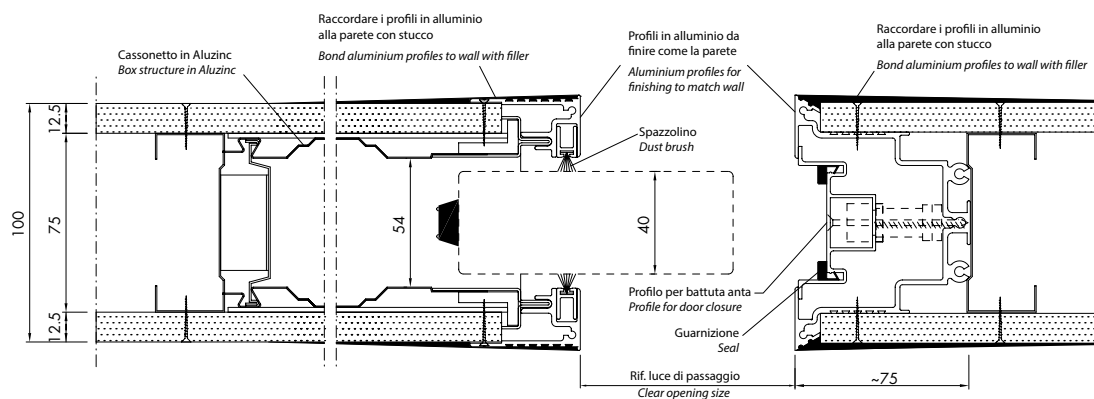

Parete in muratura da 105 mm  
 Masonry walls with thicknesses 105 mm

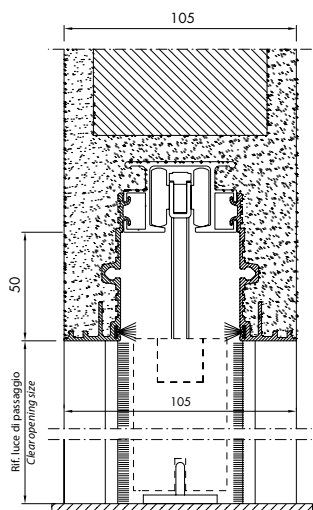

Parete in Cartongesso da 100 mm  
 Plasterboard walls with thicknesses 100 mm

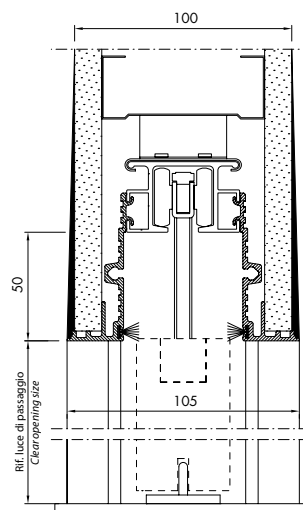



# Essential scorrevole EI 30

## Sliding EI 30

Cartongesso  
Plasterboard

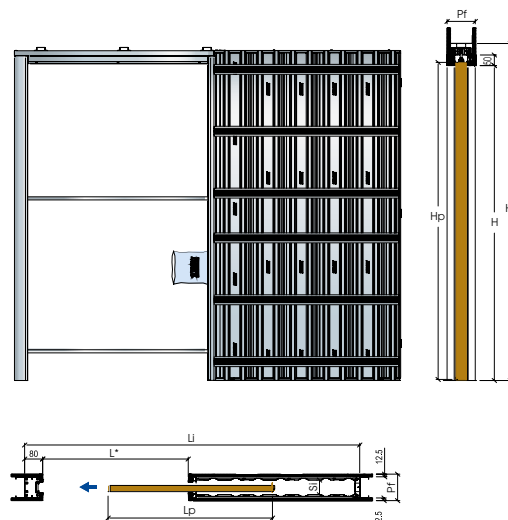
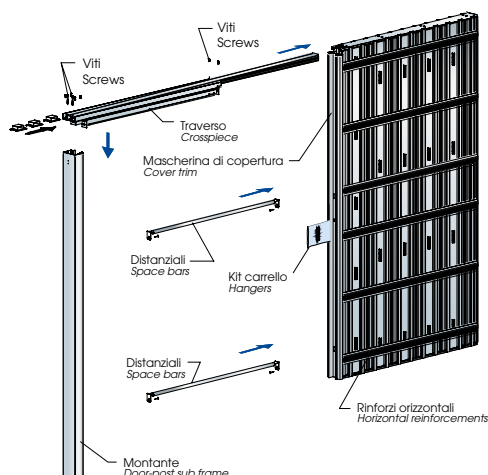

### Standard Standard

Luce di passaggio Clear opening size		Dimensione pannello		Misura d'ingombro Structural opening size		Parete finita/Sede interna Finished wall/Internal space
L*	H	Lp	Hp	Li	Hi	Pf/Si
596	da 1900 a 2400	630	da 1910 a 2410	1330	da 2005 a 2505	125/69
696		730		1530		
796		830		1730		
896		930		1930		
996		1030		2130		
1096		1130		2330		
1196		1230		2530		



\* Il passaggio nominale viene ridotta di 10 mm di larghezza. / \* The nominal passage is reduced by 10 mm wide.

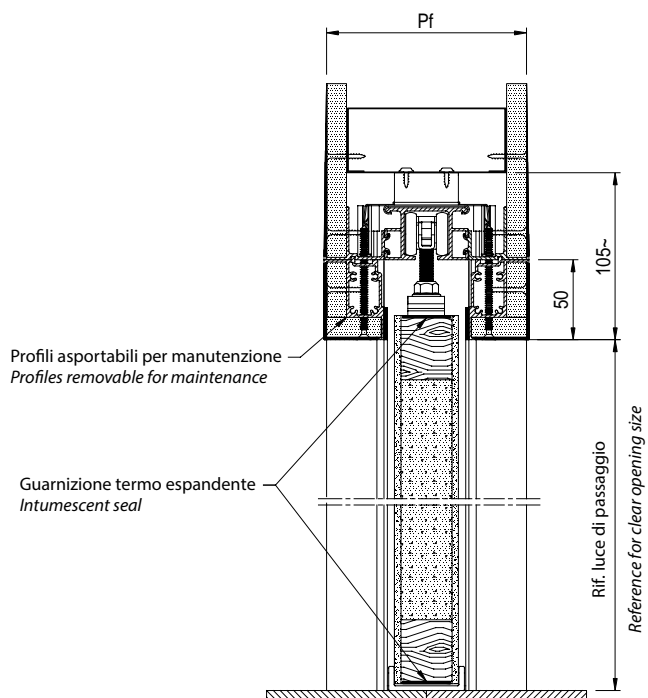
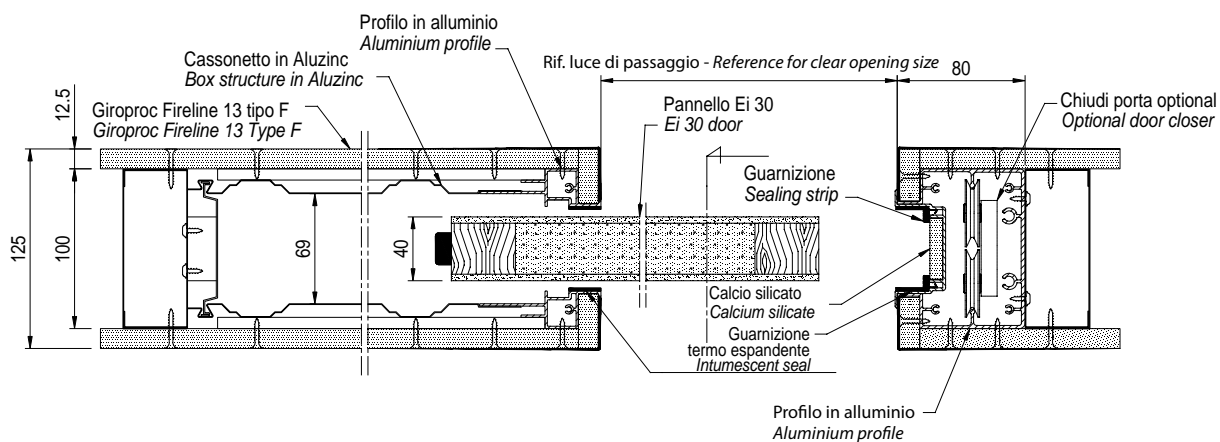

E' obbligatorio abbinare al controtelaio la porta e gli accessori specifici - The frame must be combined with its specific door and accessories.

#### Legenda Legend

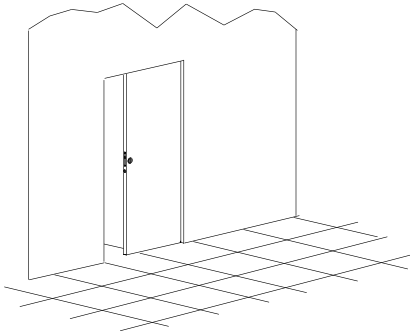
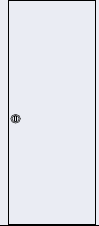
- L = Larghezza luce  
Opening Width
- H = Altezza luce  
Opening Height
- Li = Ingombro in larghezza  
Overall Width
- Hi = Ingombro in altezza  
Overall Height
- Lp = Larghezza pannello  
Width Panel
- Hp = Altezza pannello  
Height Panel
- Pf = Parete finita  
Finished Wall
- Si = Sede interna  
Internal Space

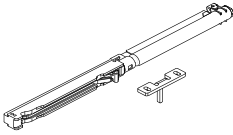
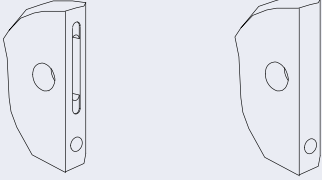

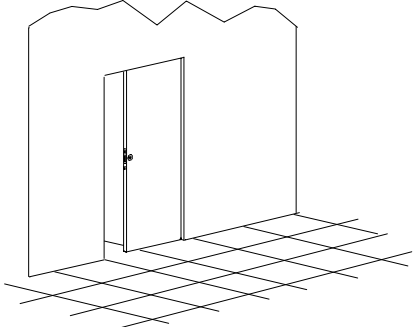
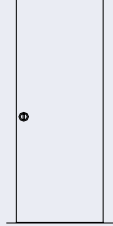
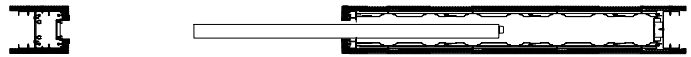
<p>Funzionamento</p>	 <p>Essential Scorrevole Ei30 è il controtelaio per interni, che abbina la resistenza al fuoco al desing. Sono stati sostituiti il montante in legno, gli incastrì per gli stipiti, le cornici coprifilo con profili in alluminio grezzo, sui quali viene direttamente rasato il cartongesso. Con la tinteggiatura dei profili si ottiene la completa fusione della porta con la parete che risulta libera da ogni coprifilo.</p>
<p>Forme disponibili</p>	 <p>Dimensioni:</p> <ul style="list-style-type: none"> <li>• Larghezza (in mm) da 596* a 1196* passo 100 mm</li> <li>• Altezza (in mm) tutte le misure da 1900 a 2400 passo 1 mm</li> </ul> <p>* il passaggio effettivo risulta ridotto di 10 mm</p>
<p>Tipologia apertura</p>	 <p>Scorrevole a scomparsa anta unica</p>
<p>Spessore parete</p>	<p>Parete finita:</p> <ul style="list-style-type: none"> <li>• 125 mm in cartongesso</li> </ul>
<p>Classe di resistenza al fuoco</p>	<p>Disponibile:</p> <ul style="list-style-type: none"> <li>• EI<sub>2</sub> 30</li> </ul>
<p>Certificazioni</p>	<p>Certificata secondo EN 1363-1 : 2012 e EN 1634-1 : 2014 Istanza di omologazione: RN284EI2030P002</p>
<p>Finiture Pannello</p>	<ul style="list-style-type: none"> <li>•MDF Grezzo</li> </ul>
<p>Pannello</p>	<p>Spessore 40 mm composto da telaio in legno duro e materiale termoisolante, placcato con mdf da 4 mm.</p> <ul style="list-style-type: none"> <li>• pannello standard predisposto con foro maniglia con serratura.</li> </ul>
<p>Guarnizioni</p>	<ul style="list-style-type: none"> <li>• Bianche per la battuta anteriore</li> <li>• Nere le termo-espandenti</li> </ul>
<p>Chiudiporta</p>	 <p>Chiudiporta a gravità.</p>
<p>Ammortizzatore</p>	 <p>Ammortizzatore. Da abbinare sempre al contrappeso per limitare l'urto della porta contro la battuta.</p>
<p>Tipologia chiusura</p>	 <p>Predisposizione (solo foratura) per kit chiudiscugno:</p> <ul style="list-style-type: none"> <li>• con serratura</li> <li>• senza serratura</li> </ul>

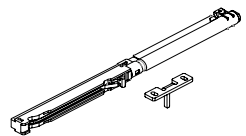
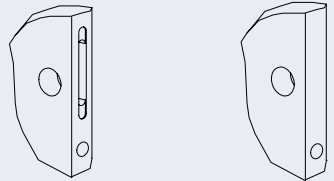
<p>Operation</p>	 <p>Essential Sliding Ei30 is a frame for interior use that combines fire resistance with fine design. The wooden upright, joints for door posts and edging trims have been replaced with coarse-finished aluminium profile bars, against which the plasterboard can be directly smoothed with filler. When painted over, the profile bars allow the door to merge seamlessly with the wall, now free from all trims.</p>
<p>Shapes available</p>	 <p>Dimensions:</p> <ul style="list-style-type: none"> <li>• Width (in mm) from 596* to 1196* in steps of 100 mm</li> <li>• Width (in mm) all sizes from 1900 to 2400 in steps of 1 mm</li> </ul> <p>* The effective opening size is smaller by 10 mm</p>
<p>Opening types</p>	 <p>Sliding disappearing single door</p>
<p>Wall thickness</p>	<p>Finished wall:</p> <ul style="list-style-type: none"> <li>• 125 mm in plasterboard</li> </ul>
<p>Fire resistance class</p>	<p>Available:</p> <ul style="list-style-type: none"> <li>• EI<sub>2</sub> 30</li> </ul>
<p>Certifications</p>	<p>Certified in accordance with EN 1363-1 : 2012 and EN 1634-1 : 2014 Type-approval application: RN284EI2030P002</p>
<p>Door panel finish</p>	<ul style="list-style-type: none"> <li>•MDF</li> </ul>
<p>Door panel</p>	<p>Thickness 40 mm, composed of a hardwood frame and heat insulation material, faced with 4 mm MDF.</p> <ul style="list-style-type: none"> <li>• Standard panel pre-fitted with hole for handle with lock.</li> </ul>
<p>Seals</p>	<ul style="list-style-type: none"> <li>• White for the front upright</li> <li>• Black for intumescent seals</li> </ul>
<p>Door closer</p>	 <p>Gravity-operated door closer.</p>
<p>Shock absorber</p>	 <p>Shock absorber. Must always be used together with a counterweight to limit the impact of the door against the upright.</p>
<p>Closure type</p>	 <p>Pre-mortised (hole only) for Chiudiscigno Kit:</p> <ul style="list-style-type: none"> <li>• with lock</li> <li>• without lock</li> </ul>

# Essential: soluzione doccia

## Essential: the shower solution

### Composizione kit / Composition of kit

Pos.	Descrizione / Description
1	Profilo appoggio montante controtelaio <i>Support profile for frame upright</i>
2	Profilo removibile in luce con sede mattonelle <i>Removable cover recessed for tiles</i>
3	Spessore di posa <i>Installation spacer</i>
4	Profilo appoggio cassonetto <i>Frame support profile</i>
5	Canalina in Inox con predisposizione per sifone <i>Stainless steel channel with hole for shower drain</i>

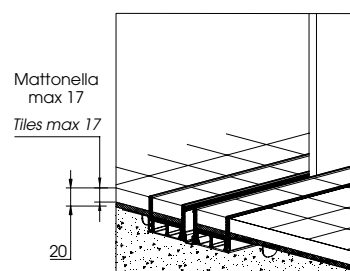
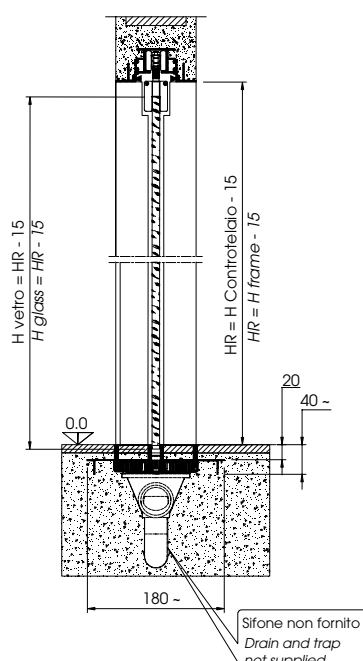
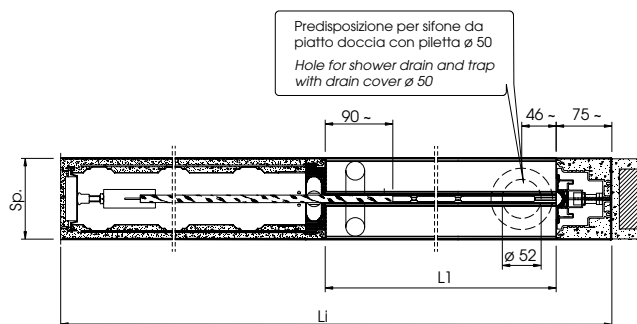
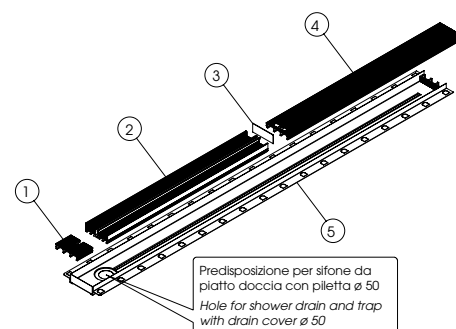

Luce di passaggio in larghezza <i>Clear opening width</i>	Luce reale <i>Effective width</i> L1	Ingombro in larghezza <i>Clear opening width</i> Li	Spessore parete <i>Wall thickness</i> Sp
600	590	1345	Intonaco <i>Plasterwork</i> 105
700	690	1545	
750	740	1645	
800	790	1745	
900	890	1945	
1000	990	2145	Cartongesso <i>Plasterboard</i> 100
1100	1090	2345	
1200	1190	2545	
			Intonaco <i>Plasterwork</i> 105

#### LEGGENDA / KEY

HR = Altezza reale di passaggio  
*Effective clear opening height*

H controtelaio =  
Altezza commerciale controtelaio  
*Frame height as sold*

H vetro = Altezza vetro - *Glass height*

L1 = Larghezza reale di passaggio  
*Effective clear opening width*

Li = Ingombro in larghezza  
kit soluzione doccia  
*Overall width of shower solution kit*

Sp = Spessore parete  
*Wall thickness*

Il kit soluzione doccia è abbinabile esclusivamente ad un controtelaio Essential Anta unica e alla relativa ferramenta vetro venduti separatamente.  
*The shower solution kit can be combined only with an Essential frame for a Single door and with the respective glass door hardware supplied separately.*



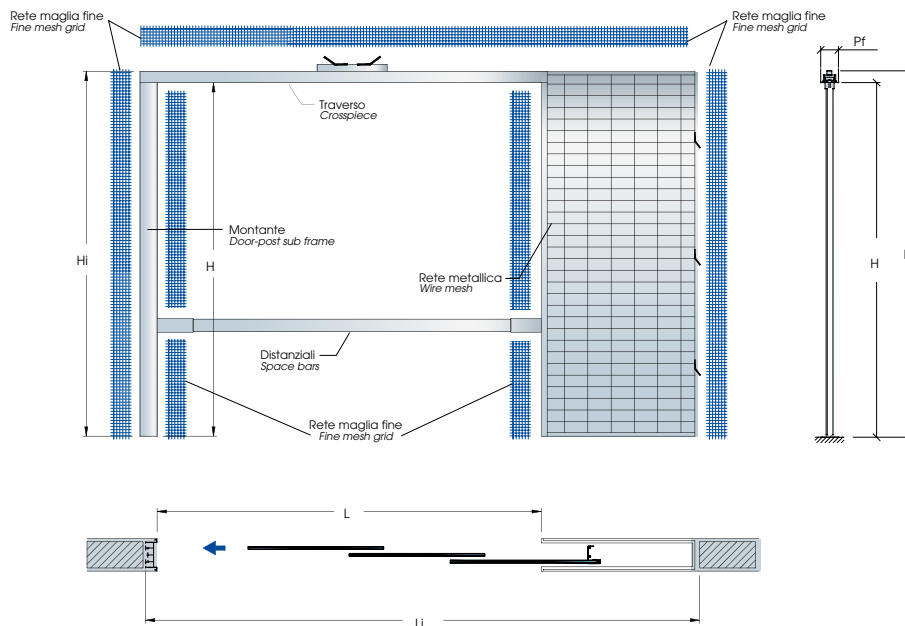

## Standard Standard

### Legenda Legend

- L = Larghezza luce  
Opening Width
- H = Altezza luce  
Opening Height
- Li = Ingombro in larghezza  
Overall Width
- Hi = Ingombro in altezza  
Overall Height
- Pf = Parete finita  
Finished Wall
- Si = Sede interna  
Internal Space

Luce di passaggio Clear opening size		Misura d'ingombro Structural opening size		Parete finita/Sede interna Finished wall/Internal space
L	H	Li	Hi	Pf / Si
1650		2375		
1800		2575		
1950		2775		
2100		2975		
2250	2100	3175	2180	140 / 102
2400		3375		
2550		3575		
2700		3775		
2850		3975		

Le particolari caratteristiche del contro telaio Essential Trial, rendono indispensabile l'abbinamento con la sua specifica ferramenta. Prima di ordinare i vetri è necessario verificare in cantiere l'effettiva misura della luce di passaggio. Essa si rileva ad installazione avvenuta del contro telaio. I profili che delimitano la luce di passaggio sono in alluminio grezzo da tinteggiare. Altezze superiori ai 2100 mm sono disponibili a richiesta e previa approvazione del nostro ufficio. Dotazione di serie: posteriore anta in alluminio grezzo da tinteggiare.

*The special characteristics of the Essential Trial frame make it essential for it to be combined with its specific hardware fittings. Before ordering glass panels, the effective opening dimension must be checked directly on site. This dimension must be measured after frame installation. The profile bars around the door opening are made in unfinished aluminium to be painted. Heights greater than 2100 mm are available on request, following approval by our technical office. Standard accessories: panel rear in unfinished aluminium to be painted.*

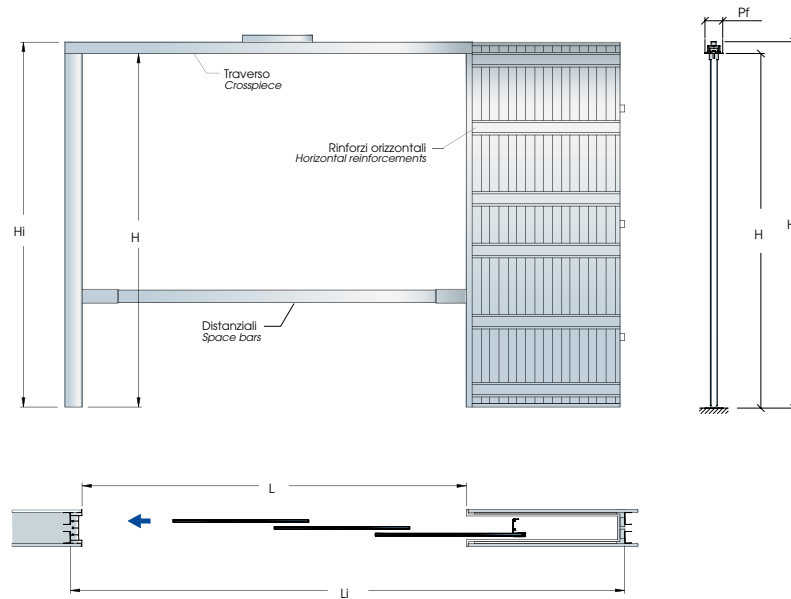

Standard  
Standard

Luce di passaggio Clear opening size		Misura d'ingombro Structural opening size		Parete finita/Sede interna Finished wall/Internal space
L	H	Li	Hi	Pf / Si
1650	2100	2375	2180	158 / 102
1800		2575		
1950		2775		
2100		2975		
2250		3175		
2400		3375		
2550		3575		
2700		3775		
2850		3975		

Legenda  
Legend

L = Larghezza luce  
Opening Width  
H = Altezza luce  
Opening Height  
Li = Ingombro in larghezza  
Overall Width  
Hi = Ingombro in altezza  
Overall Height  
Pf = Parete finita  
Finished Wall  
Si = Sede interna  
Internal Space

Le particolari caratteristiche del controtelaio Essential Trial, rendono indispensabile l'abbinamento con la sua specifica ferramenta. Prima di ordinare i vetri è necessario verificare in cantiere l'effettiva misura della luce di passaggio. Essa si rileva ad installazione avvenuta del controtelaio. I profili che delimitano la luce di passaggio sono in alluminio grezzo da tinteggiare. Altezze superiori al 2100 mm sono disponibili a richiesta e previa approvazione del nostro ufficio. Dotazione di serie: posteriore anta in alluminio grezzo da tinteggiare. I controtelai per Cartongesso sono predisposti per lastre dello spessore di 12,5 mm per lato.

The special characteristics of the Essential Trial frame make it essential for it to be combined with its specific hardware fittings. Before ordering glass panels, the effective opening dimension must be checked directly on site. This dimension must be measured after frame installation. The profile bars around the door opening are made in unfinished aluminium to be painted. Heights greater than 2100 mm are available on request, following approval by our technical office. Standard accessories: panel rear in unfinished aluminium to be painted. Sliding door frames for plasterboard are designed for plasterboard panels with a thickness of 12.5 mm on each side.

# Essential Trial

Controtelaio per vetri scorrevoli a scomparsa senza stipite per parete in muratura da 140 mm  
 Frame for sliding disappearing glasses without doorpost for masonry walls with thickness 140 mm.

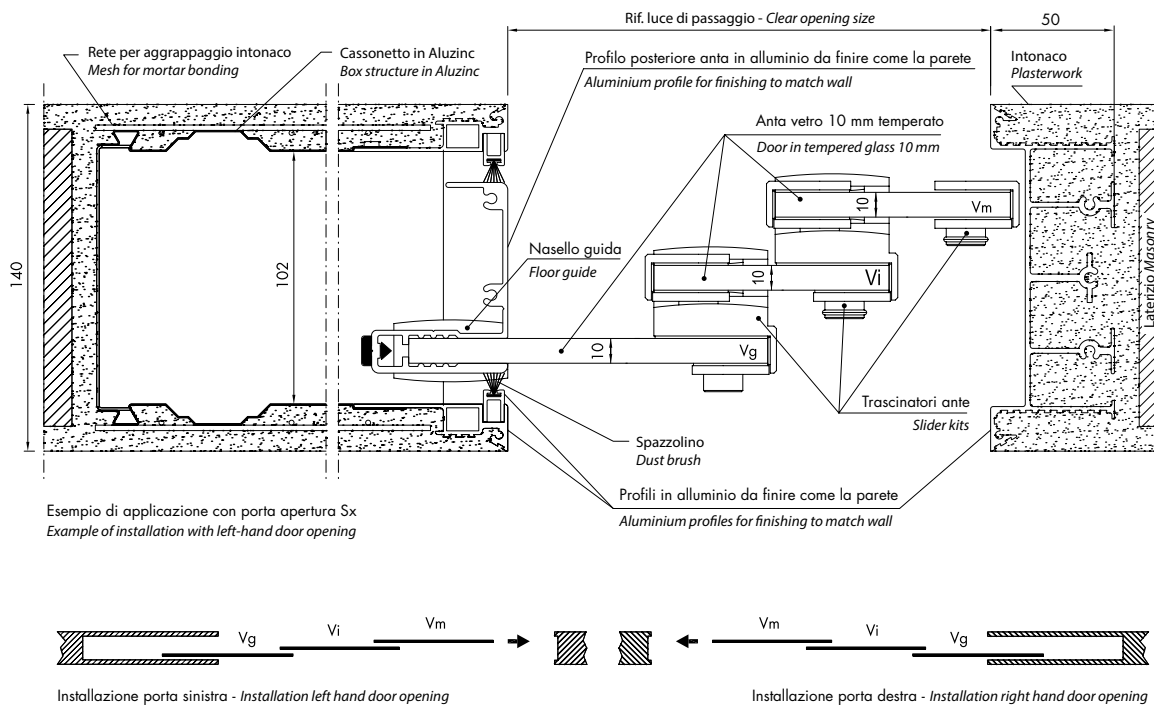

Controtelaio per vetri scorrevoli a scomparsa senza stipite per parete in Cartongesso da 158 mm  
 Frame for sliding disappearing glasses without doorpost for masonry walls thickness 158 mm

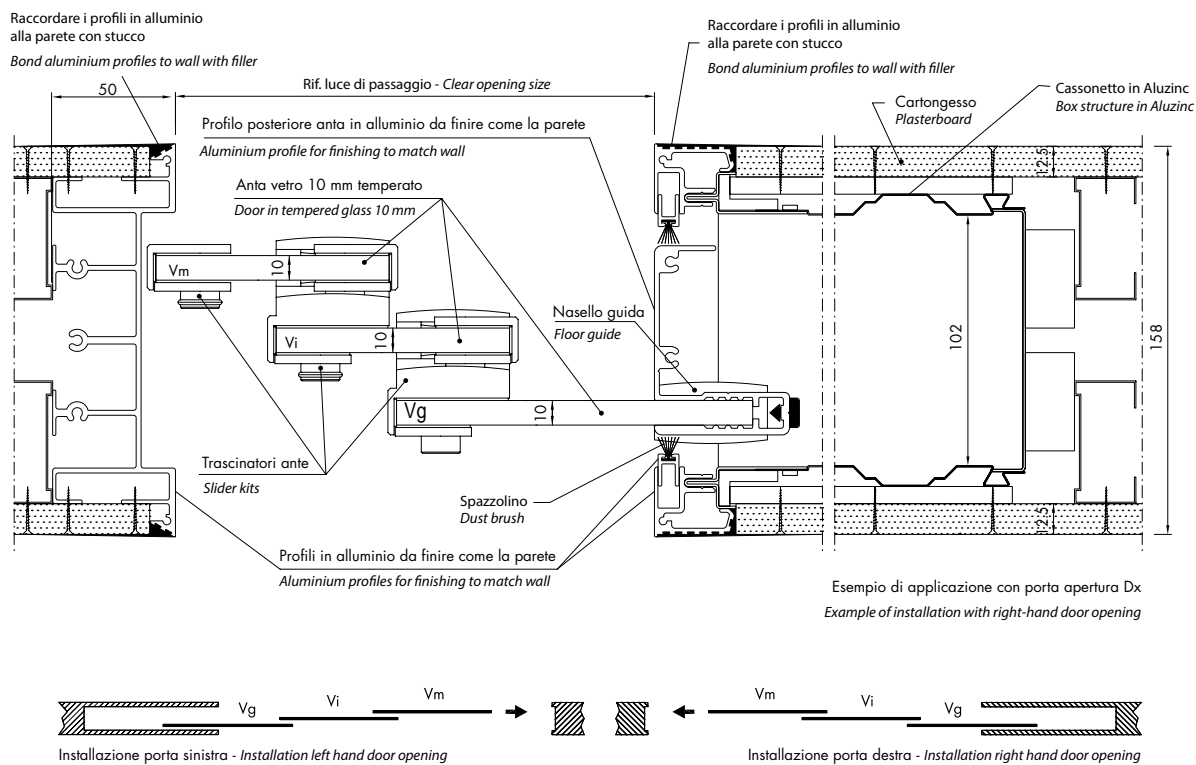

Le particolari caratteristiche del controtelaio Essential Trial, rendono indispensabile l'abbinamento con la sua specifica ferramenta. Prima di ordinare i vetri è necessario verificare in cantiere l'effettiva misura della luce di passaggio. Essa si rileva ad installazione avvenuta del controtelaio.

The special characteristics of the Essential Trial frame make it essential for it to be combined with its specific hardware fittings. Before ordering glasses, the effective opening dimension must be checked directly on site. This dimension must be measured after frame installation.



# Essential Dual

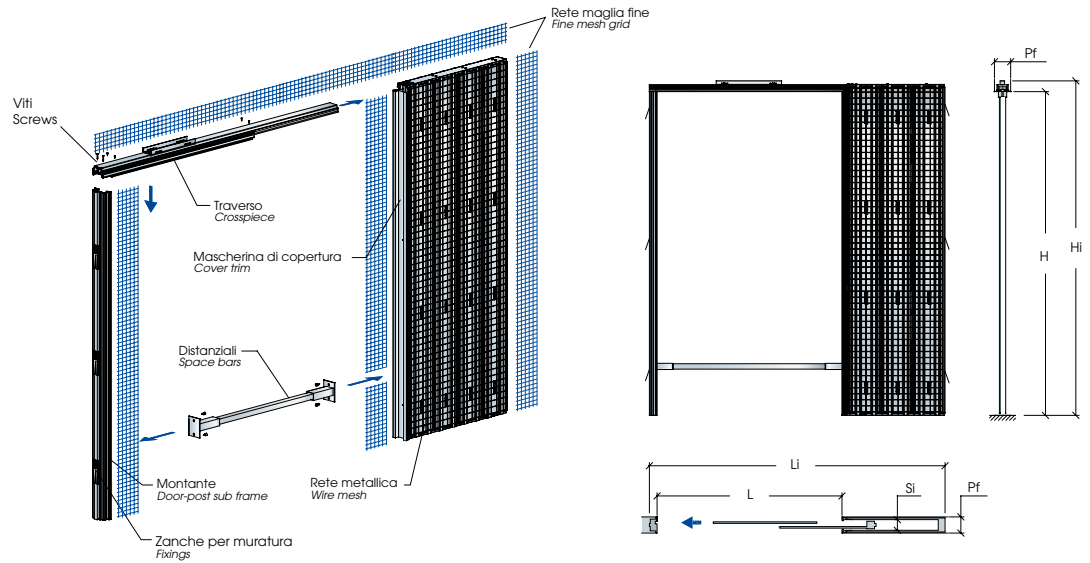

## Standard Standard

### Legenda Legend

L = Larghezza luce  
Opening Width

H = Altezza luce  
Opening Height

Li = Ingombro in larghezza  
Overall Width

Hi = Ingombro in altezza  
Overall Height

Pf = Parete finita  
Finished Wall

Si = Sede interna  
Internal Space

Luce di passaggio Clear opening size		Misura d'ingombro Structural opening size		Parete finita/Sede interna Finished wall/Internal space
L	H	Li	Hi	Pf / Si
1200	2000/2100	1910	2070/2170	105/69
1400		2210		
1600		2510		

## Fuori misura Extra Height

Luce di passaggio Clear opening size		Misura d'ingombro Structural opening size		Parete finita/Sede interna Finished wall/Internal space
L	H	Li	Hi	Pf / Si
1200	2010÷2020 2110÷2400	1910	2080÷2160 2180÷2470	105/69
1400		2210		
1600		2510		

Prima di ordinare/realizzare la porta per il controtelaio Essential Dual è necessario verificare in cantiere l'effettiva misura della luce di passaggio. Essa si rileva ad installazione avvenuta del controtelaio.

*Before ordering the door for the Essential Dual frame, the effective clear opening size must be checked onsite. This must be measured after the installation of the frame.*

La luce di passaggio effettiva a porta installata è ridotta in larghezza di 140 mm.  
*The effective clear opening size with the door installed is reduced in width by 140 mm.*

Le particolari caratteristiche del controtelaio Essential Dual rendono indispensabile l'abbinamento o con la sua porta vetro finita, oppure con la sua specifica ferramenta.  
*The special characteristics of the Essential Dual frame make it essential for it to be combined with the finished glass door or its specific hardware fittings.*



# Essential Battente

## Essential Swing

Anta unica  
Single door

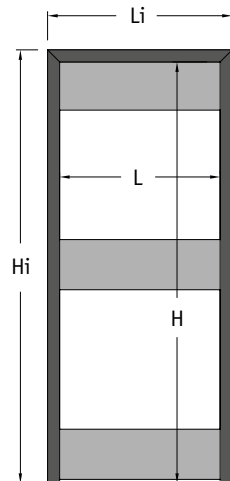

Spingere/Push  
105i/100c

Tirare/Pull  
105i/100c

Tirare/Pull  
90i Oltre  
100/125c

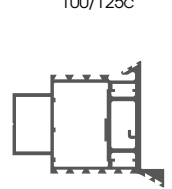
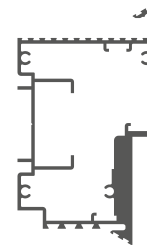
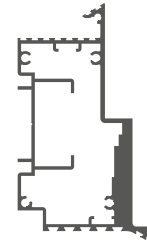

### Legenda Legend

- L = Larghezza luce  
Opening Width
- H = Altezza luce  
Opening Height
- Li = Ingombro in larghezza  
Overall Width
- Hi = Ingombro in altezza  
Overall Height
- Sp = Spessore parete  
Finished Wall

Luce di passaggio Clear opening size		Misura d'ingombro Structural opening size		Spessore parete Finished wall
L	H	Li	Hi	SP
600	1800÷2700	730	1815÷2765	105 Intonaco plastered 100 Cartongesso plasterboard
700		830		
800		930		
900		1030		
600	1800÷2700	750	1875÷2775	90 oltre Intonaco over plastered 100/125 Cartongesso plasterboard
700		850		
800		950		
900		1050		

Intonaco 105 - Cartongesso 100 • Plastered 105 - Plasterboard 100

Intonaco 90 oltre - Cartongesso 100/125 • Plastered 90 and over - Plasterboard 100/125

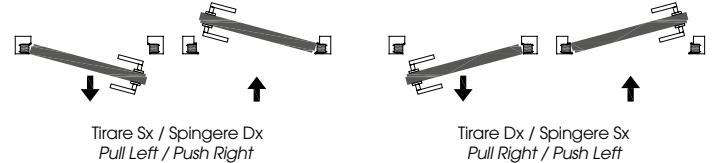
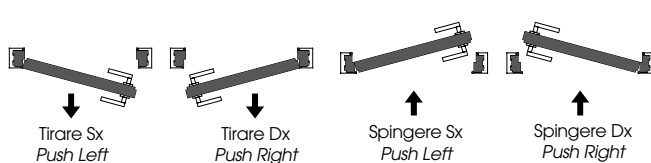

La versione a spingere consente l'apertura massima dell'anta di 90°/100°, con conseguente riduzione della luce di passaggio.

In caso di affiancamento di porte a Spingere e Tirare sulla stessa parete, fra i due modelli, a parità di luce di passaggio, il foro luce del modello Tirare presenta una differenza in altezza di + 10 mm e in larghezza di + 20 mm.

Le particolari caratteristiche del telaio Essential Battente rendono indispensabile l'abbinamento con la ferramenta specifica.

The push version permits maximum door opening to 90°/100°, with a consequent reduction of the clear opening width.

If push and pull models are placed adjacently on the same wall, the clear opening size on the pull model is 10 mm higher and 20 mm wider than the push model.

The special characteristics of the Essential Swing frame make it essential for it to be combined with its specific hardware fittings.

The Essential swing door frame needs to be combined with its specific hardware fittings.

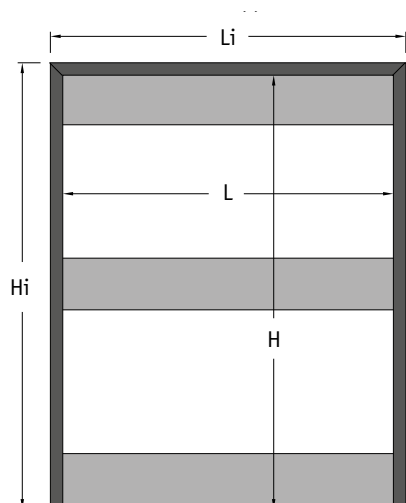

Spingere/Push  
105i/100c

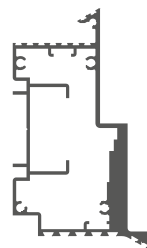

Tirare/Pull  
105i/100c

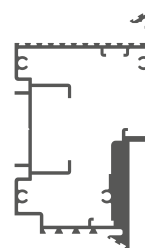

Tirare/Pull  
90i Oltre  
100/125c

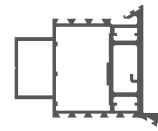

Luce di passaggio Clear opening size		Misura d'ingombro Structural opening size		Spessore parete Finished wall
L	H	Li	Hi	SP
1200÷1800	1800÷2700	1330÷1930	1865÷2765	105 Intonaco plastered 100 Cartongesso plasterboard
		1350÷1950	1875÷2775	90 oltre Intonaco over plastered 100/125 Cartongesso plasterboard

Legenda  
Legend

- L = Larghezza luce  
Opening Width
- H = Altezza luce  
Opening Height
- Li = Ingombro in larghezza  
Overall Width
- Hi = Ingombro in altezza  
Overall Height
- Sp = Spessore parete  
Finished Wall

Intonaco 105 - Cartongesso 100 • Plastered 105 - Plasterboard 100

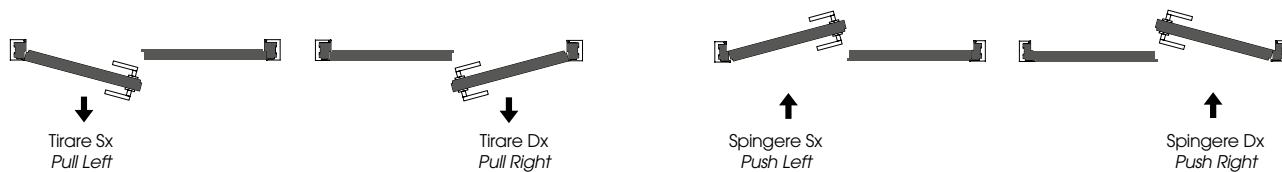

Intonaco 90 oltre - Cartongesso 100/125 • Plastered 90 and over - Plasterboard 100/125

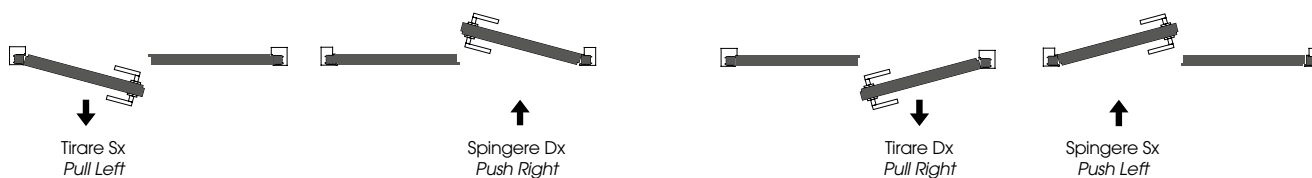

La versione a spingere consente l'apertura massima dell'anta di 90°/100°, con conseguente riduzione della luce di passaggio.

In caso di affiancamento di porte a Spingere e Tirare sulla stessa parete, fra i due modelli, a parità di luce di passaggio, il foro luce del modello Tirare presenta una differenza in altezza di + 10 mm e in larghezza di + 20 mm.

Le particolari caratteristiche del telaio Essential Battente rendono indispensabile l'abbinamento con la ferramenta specifica.

The push version permits maximum door opening to 90°/100°, with a consequent reduction of the clear opening width.

If push and pull models are placed adjacently on the same wall, the clear opening size on the pull model is 10 mm higher and 20 mm wider than the push model.

The special characteristics of the Essential Swing frame make it essential for it to be combined with its specific hardware fittings.

The Essential swing door frame needs to be combined with its specific hardware fittings.

# Essential Battente • Telaio Senza Traverso

*Essential Swing • Frame without upper crosspiece*

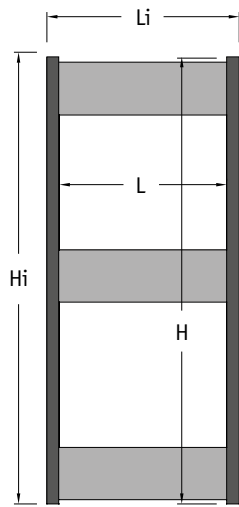

Spingere/Push  
105i/100c

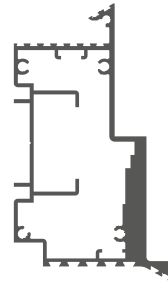

Tirare/Pull  
105i/100c

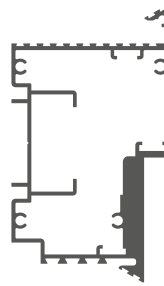

Tirare/Pull  
90i Oltre  
100/125c

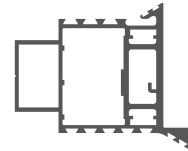

Luce di passaggio <i>Clear opening size</i>		Misura d'ingombro <i>Structural opening size</i>		Spessore parete <i>Finished wall</i>
L	H	Li	Hi	SP
600÷1000	1800÷3000	730÷1130	1805÷3005	105 intonaco/plastered 100 cartongesso/plasterboard
	1800÷2400	750÷1150	1805÷2405	90 oltre Intonaco over plastered 100/125 Cartongesso plasterboard

Legenda  
*Legend*

- L = Larghezza luce  
*Opening Width*
- H = Altezza luce  
*Opening Height*
- Li = Ingombro in larghezza  
*Overall Width*
- Hi = Ingombro in altezza  
*Overall Height*
- Sp = Spessore parete  
*Finished Wall*

Intonaco 105 - Cartongesso 100 • Plastered 105 - Plasterboard 100

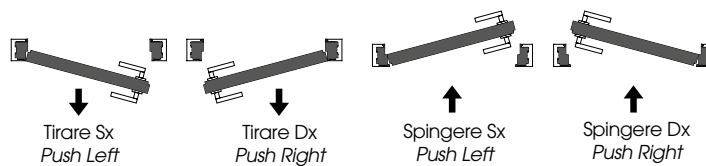

Intonaco 90 Oltre - Cartongesso 100/125 • Plastered 90 and over - Plasterboard 100/125

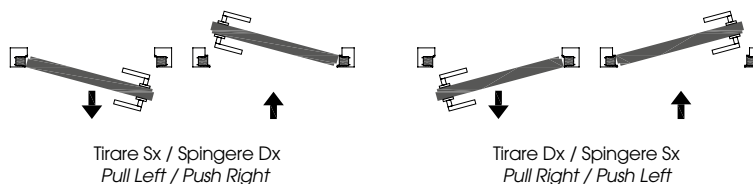

# Essential Battente • Telaio Trapezoidale

*Essential Swing • Trapezoidal shape frame*

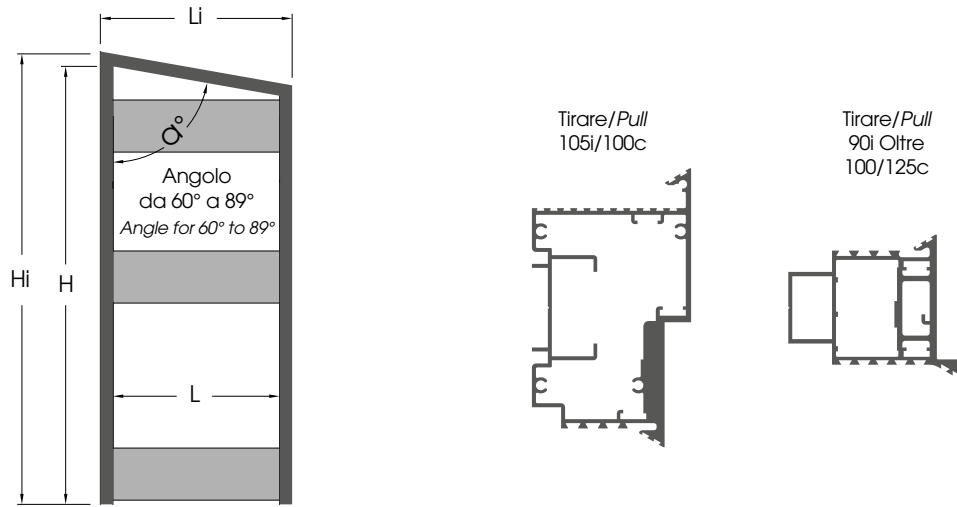

Luce di passaggio <i>Clear opening size</i>		Misura d'ingombro <i>Structural opening size</i>		Spessore parete <i>Finished wall</i>
L	H	$L_i$	$H_i^*$	SP
600÷1000	1800÷2700	730÷1130	1905÷2805	105 Intonaco/ <i>plastered</i> 100 Cartongesso/ <i>plasterboard</i>
		750÷1150	1920÷2820	90 oltre Intonaco <i>over plastered</i> 100/125 Cartongesso <i>plasterboard</i>

Legenda  
*Legend*

- L = Larghezza luce  
*Opening Width*
- H = Altezza luce  
*Opening Height*
- $L_i$  = Ingombro in larghezza  
*Overall Width*
- $H_i$  = Ingombro in altezza  
*Overall Height*
- Sp = Spessore parete  
*Finished Wall*

\* Ingombro massimo con un angolo di  $60^\circ$  - \* *Maximum volume at an angle of  $60^\circ$*

Le particolari caratteristiche del telaio Essential Battente rendono indispensabile l'abbinamento con la ferramenta specifica.  
*The Essential swing door frame needs to be combined with its specific hardware fittings.*

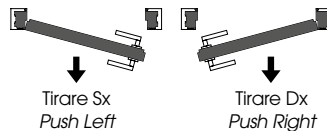

# Essential Battente

## Essential Swing

Essential Battente per parete Intonaco 105 mm e cartongesso 100 mm - modello a Tirare.  
 Essential Swing door, pull model, for masonry thickness 105 mm and for plasterboard 100 mm.

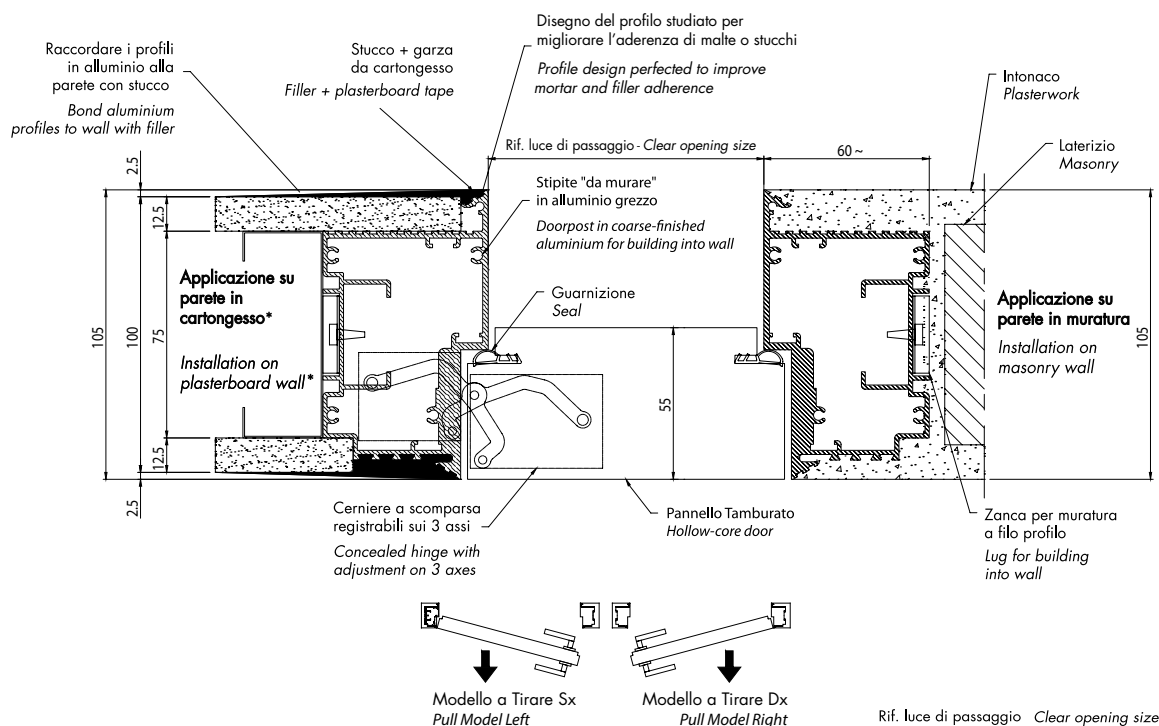

Essential Battente per parete Intonaco 105 mm e cartongesso 100 mm - modello a Spingere.  
 Essential Swing door, push model, for masonry thickness 105 mm and for plasterboard 100 mm.

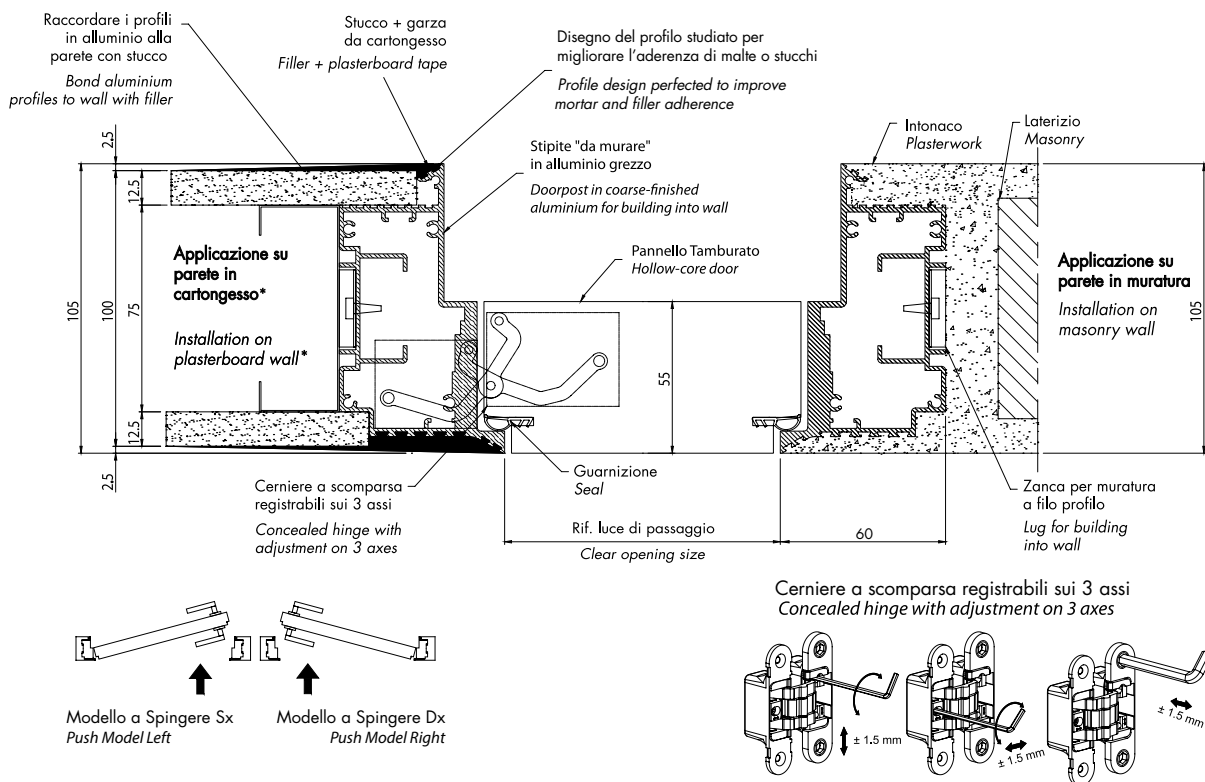

# Essential Battente

Essential Battente profilo universale per pareti Intonaco 90 mm e oltre o Cartongesso 100 - 125 mm.  
 Essential swinging door - universal profile for masonry wall 90mm and over or 100 mm plasterboard.

Esempio di montaggio a Tirare Sx  
 Example of pull model installation Left

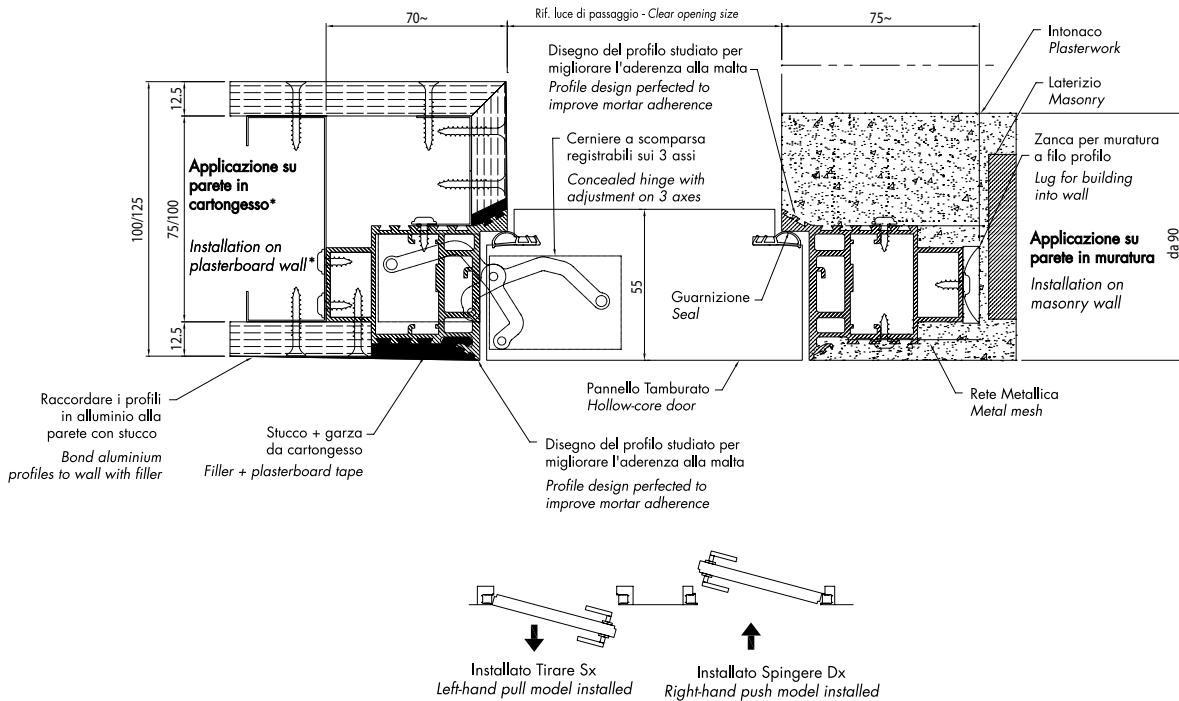

Essential Battente profilo universale per pareti Intonaco 90 mm e oltre o Cartongesso 100 - 125 mm.  
 Essential swinging door - universal profile for masonry wall 90 mm and over or 100 mm plasterboard.

Esempio di montaggio a Spingere Sx  
 Example of push model installation Left

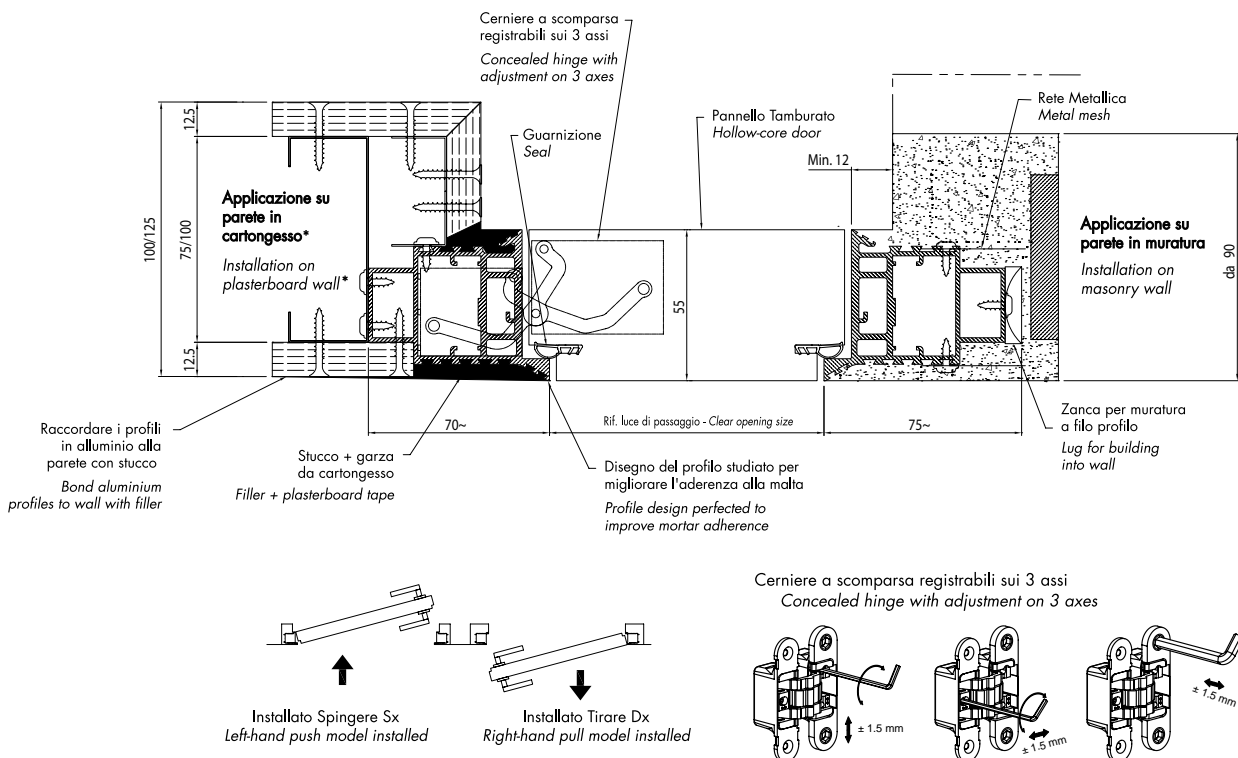

# Essential Battente EI 30/60

## Essential EI 30/60 Swing

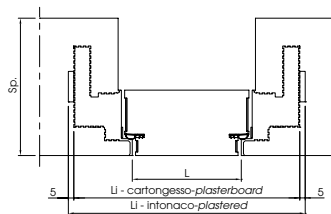

Apertura max. della porta 90°  
Opening max. the door 90°

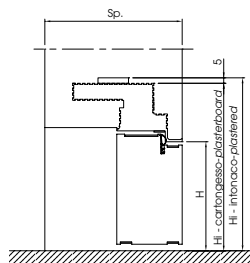
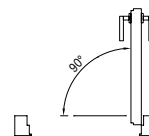

Senso di apertura - Opening direction

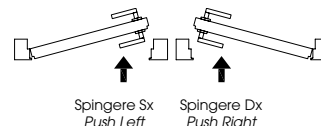

### Essential Battente EI 30 (X122)

Essential swinging door EI 30 (x122)

1/2 ORA  
1/2 HOUR

Legenda  
Legend

- L = Larghezza luce  
Opening Width
- H = Altezza luce  
Opening Height
- Li = Ingombro in larghezza  
Overall Width
- Hi = Ingombro in altezza  
Overall Height
- Sp = Spessore parete  
Finished Wall

Luce di passaggio Clear opening size		Misura d'ingombro Structural opening size		Spessore parete Finished wall
L	H	Li	Hi	Sp
600	2000÷2650	730	2065÷2715	125 o superiore Intonaco/Cartongesso 125 or over plastered /plasterboard
700		830		
800		930		
900		1030		
1000		1130		
1100	2000÷2530	1230	2065÷2595	

### Essential Battente EI 60 (X122)

Essential swinging door EI 60 (x122)

1 ORA  
1 HOUR

Luce di passaggio Clear opening size		Misura d'ingombro Structural opening size		Spessore parete Finished wall
L	H	Li	Hi	Sp
600	2000÷2650	730	2065÷2715	125 o superiore Intonaco/Cartongesso 125 or over plastered /plasterboard
700		830		
800		930		
900		1030		
1000		1130		
1100	2000÷2530	1230	2065÷2595	

Prodotto certificato UNI EN 1634-1:2009. La larghezza di passaggio effettiva è ridotta in larghezza di 60 mm.  
Product certified to the UNI EN 1634-1:2009 standards. The effective clear opening size is reduced in width by 60 mm.

# Essential Battente EI 30 (X122)

## Essential Swing EI 30 (X122)

Essential Battente EI 30 X122 per parete in muratura o Cartongesso.

Essential EI 30 X122 swinging door - for masonry and plasterboard walls.

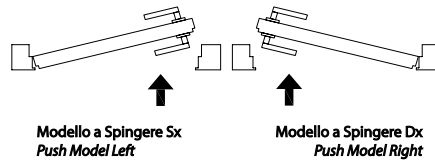
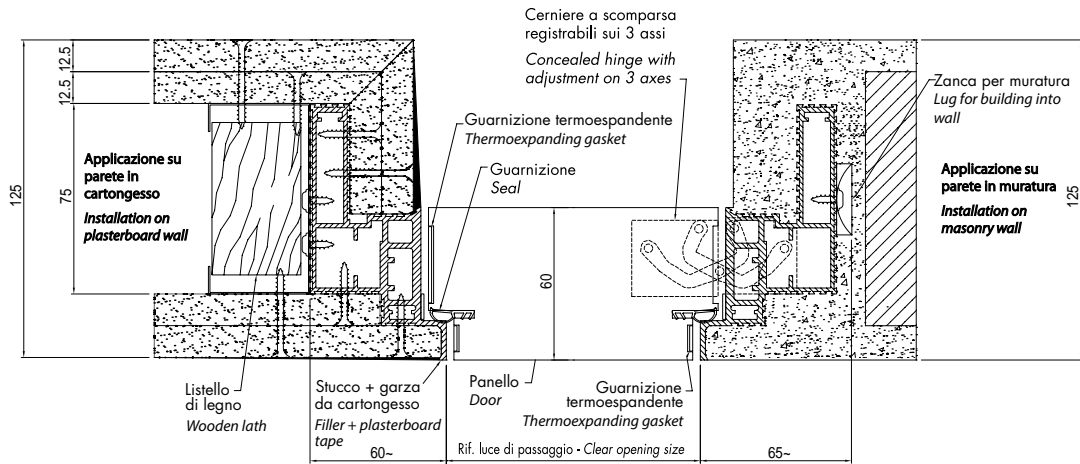

# Essential Battente EI 60 (X122)



## Essential Swing EI 60 (X122)

Essential Battente EI 60 X122 per parete in muratura o Cartongesso.

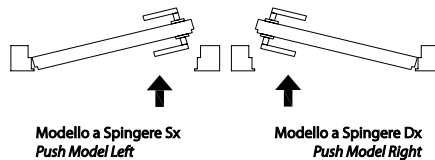
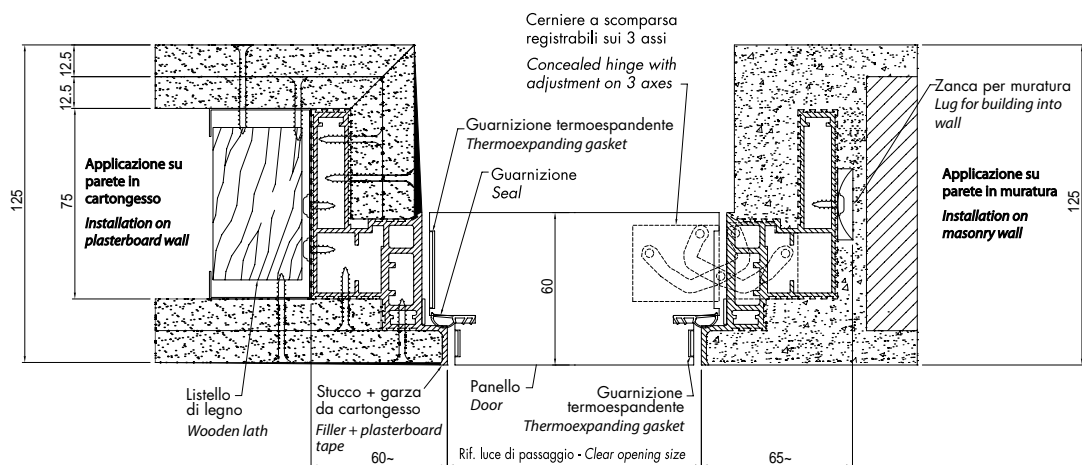

Essential EI 60 X122 swinging door - for masonry and plasterboard walls.

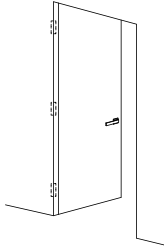
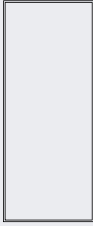

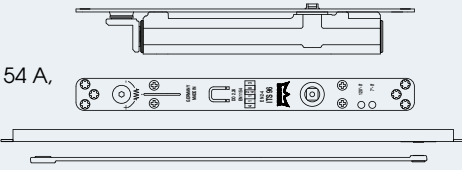

# Essential Battente EI 30/60 (X122)

<p>Funzionamento</p>	 <p>Porta a filo parete con gioco fra pannello e telaio di circa 3 mm. Rotazione su cerniere a scomparsa. Massima apertura 90°.</p>	
<p>Dimensioni disponibili</p>	 <ul style="list-style-type: none"> <li>• Larghezza da 600 a 1100* mm.</li> <li>• Altezza: tutte le misure da 2000 a 2650 mm.</li> </ul> <p>* Per la larghezza da 1100 mm, l'altezza massima è 2530 mm.</p>	
<p>Tipologia apertura</p>	 <p>Modello Sinistro a Spingere      Modello Destro a Spingere</p> <p>L'apertura a spingere consente l'apertura dell'anta a 90°, questo riduce la luce di passaggio di circa 60 mm.</p>	
<p>Classe di resistenza al fuoco</p>	<ul style="list-style-type: none"> <li>• EI 30 _ EI1 30'</li> <li>• EI 60 _ EI1 60'</li> </ul>	
<p>Certificazioni</p>	<p>Certificata secondo UNI EN 1634-1:2009 ed omologata come da D.M. 21/06/2004:</p> <ul style="list-style-type: none"> <li>• istanza di omologazione RN284EI1060P001 (EI 60)</li> <li>• istanza di omologazione RN284EI1060P001D30 (EI 30)</li> <li>• certificato di prova di resistenza al fuoco N° 52/U/12-164FR.</li> </ul>	<p>Abbattimento acustico: Rw 23(-1;0) dB secondo ISO 717-1(2000). Risultato ottenuto con chiudiporta incassato Dorma e guarnizione sottoporta.</p>
<p>Finiture Pannello</p>	<ul style="list-style-type: none"> <li>• Con fondo (primer)</li> </ul>	
<p>Spessore parete</p>	<p>Parete finita:</p> <ul style="list-style-type: none"> <li>• 125 mm o superiore in muratura</li> <li>• 125 mm o superiore in cartongesso</li> </ul>	
<p>Pannello</p>	<p>Spessore 60 mm composto da telaio in legno duro e materiale termoisolante, placcato con mdf da 3 mm con guarnizione perimetrale di battuta. Pannello predisposto con foro maniglia e cilindro.</p>	
<p>Guarnizioni</p>	<ul style="list-style-type: none"> <li>• In pvc di colore nero o bianco per la tenuta dell'aria</li> <li>• Termoespandenti di colore nero o bianco per la tenuta dei fumi caldi</li> <li>Optional:</li> <li>• Guarnizione sottoporta (paraspiifferi)</li> </ul>	
<p>Rostrì per porte tagliafuoco</p>	<p>n° 3 rostro passivo SC-Firebolt in Fe zincato n° 3 rostro attivo SC-Firebolt in Fe zincato</p>	
<p>Cerniere</p>	<p>n°5 Cerniere a scomparsa registrabili sui 3 assi, verniciate argento. Registrazioni consentite:</p> <ul style="list-style-type: none"> <li>• Regolazione verticale <math>\pm 2</math> mm</li> <li>• Regolazione in pressione <math>\pm 1</math> mm</li> <li>• Regolazione orizzontale <math>\pm 1,5</math> mm</li> </ul>	

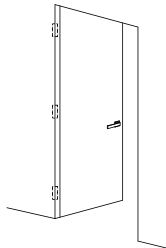
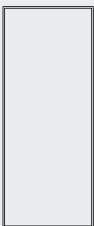

# Essential Battente EI 30/60 (X122)

<p>Chiudiporta</p>	<p>Incassato Dorma ITS 96 EN 2-4. Chiudiporta con azionamento a camma integrato nel pannello porta, marcato CE secondo la normativa EN 1154 A, con coppia di apertura/forza a decremento rapido. Forza di chiusura, velocità di chiusura e azione di scatto regolabili.</p> 
<p>Tipologia chiusura</p>	 <p>Serratura: A. Serratura Sicurezza E70 F22 B. Opera SL E70 F22 (senza antieffrazione) C. Opera DQ SL E70 F22</p>
<p>Finiture serrature e incontro elettrico</p>	<ul style="list-style-type: none"> <li>• Cromo opaco</li> </ul>
<p>Descrizione funzionamento serrature</p>	<p>Sicurezza SL entrata 70 frontale 22. Serratura tradizionale con scrocco e catenaccio azionato da cilindro a profilo Din V 18254. Lo scrocco a leva assicura il massimo silenzio nella chiusura della porta, specialmente quando è installato un chiudiporta automatico. La serratura è marcata CE secondo la normativa EN 12209:2003/AC:2005 ed è quindi certificata per l'utilizzo su porte tagliafuoco e tagliafuoco. Non è possibile installare le maniglie con viti passanti.</p>
	<p>Opera Hotel SL entrata 70 frontale 22 senza antieffrazione. Serratura antipánico per porte di Hotel e comunità. Dall'interno, abbassando la maniglia, si sbloccano istantaneamente scrocco e catenaccio consentendo l'uscita rapida dalla stanza in caso di emergenza. La serratura OPERA SL permette di utilizzare qualunque tipo di maniglia. Il segnalatore di presenza, infatti, è collocato direttamente sul cilindro. Da abbinare esclusivamente a Cilindro OPERA con rotazione limitata. Con l'utilizzo di incontri elettici, è possibile automatizzare l'apertura della porta per mezzo di badge e transponder. La serratura è marcata CE secondo la normativa EN 12209:2003/AC:2005 ed è quindi certificata per l'utilizzo su porte tagliafuoco e tagliafuoco.</p>
	<p>Opera hotel DQ SL entrata 70 frontale 22 (serratura con un solo lato antipánico). Serratura da infilare antipánico per porte di Hotel e comunità (centri di cura, di accoglienza per anziani e di villeggiatura, bagni, accessi comuni in edifici pubblici, per le quali sia utile o necessario l'utilizzo della maniglia da ambo i lati della porta). Dall'interno, abbassando la maniglia, si sbloccano istantaneamente scrocco e catenaccio consentendo l'uscita rapida dalla stanza in caso di emergenza. Abbassando la maniglia dal lato antipánico, catenaccio e scrocco rientrano nella serratura; dal lato opposto, l'abbassamento della maniglia determina il rientro solamente dello scrocco. Da abbinare esclusivamente a Cilindro OPERA a rotazione completa. Con l'utilizzo di appositi incontri elettici, è possibile automatizzare l'apertura della porta per mezzo di badge e transponder. La serratura è marcata CE secondo la normativa EN 12209:2003/AC:2005 ed è quindi certificata per l'utilizzo su porte tagliafuoco e tagliafuoco.</p>
<p>Incontro su telaio (valido per serrature sicurezza e Opera)</p>	<p>Descrizione Incontro con vaschetta regolabile (elettrificabile in un secondo momento). Utilizzo Su serrature antipánico Opera e sicurezza SL si ha un incontro normale che può diventare in secondo momento incontro elettrico sostituendo la vaschetta con un blocchetto. Non abbinabile con serratura Opera con antieffrazione.</p>
<p>Blocchetto elettrico</p>	<p>Blocchetto elettrico 12V. Ca 250/cc280mA, 24V ca 500/cc560mA senza memoria di apertura, senza leva sblocco manuale.</p>
<p>Composizione imballo</p>	<p>Composto da due colli: • collo telaio • collo anta Tutti gli accessori, cerniere, guarnizioni, chiudiporta, Firebolt e serratura sono forniti all'interno del collo telaio e sono da installare in fase di montaggio porta.</p>

# Essential Swing EI 30/60 (X122)

<p>Operation</p>	 <p>Door flush with the wall with a play of about 3 mm between the door panel and the frame. Rotation on concealed hinges.</p> <p>Maximum opening 90°.</p>
<p>Available sizes</p>	 <ul style="list-style-type: none"> <li>• Width from 600 to 1100 mm.*</li> <li>• Height: all sizes from 2000 to 2650 mm.</li> </ul> <p>* For the width of 1100 mm, the maximum height is 2530 mm.</p>
<p>Opening types</p>	 <p>Push opening allows doors to be opened to 90°, but this reduces the clear opening size by about 60 mm.</p> <p>Modello Sinistro a Spingere      Modello Destro a Spingere</p>
<p>Fire resistance class</p>	<ul style="list-style-type: none"> <li>• EI 30 _ EI 30'</li> <li>• EI 60 _ EI 60'</li> </ul>
<p>Certifications</p>	<p>Certified in accordance with UNI EN 1634-1:2009 and type-approved pursuant to Ministerial Decree 21/06/2004:</p> <ul style="list-style-type: none"> <li>• type-approval request RN284EI1060P001 (EI60)</li> <li>• type-approval request RN284EI1060P001 D30 (EI30)</li> <li>• fire resistance test certificate No. 52/U/12-164FR.</li> </ul> <p>Noise insulation: Rw 23(-1;0) dB in accordance with ISO 717-1(2000). Result obtained with incorporated Dorma door closer and bottom draught excluder.</p>
<p>Door panel finish</p>	<ul style="list-style-type: none"> <li>• Primer coat</li> </ul>
<p>Wall thickness</p>	<p>Finished wall:</p> <ul style="list-style-type: none"> <li>• 125 mm or more with plasterwork</li> <li>• 125 mm or more with plasterboard</li> </ul>
<p>Door panel</p>	<p>Thickness 60 mm, composed of a hardwood frame and heat insulation material, faced with 3 mm MDF with edging seals on closures. Door panel pre-fitted with hole for handle and lock cylinder.</p>
<p>Seals</p>	<ul style="list-style-type: none"> <li>• In black or white PVC for sealing against draughts</li> <li>• Black or white intumescent strips for sealing against hot fumes</li> </ul> <p>Optional accessories:</p> <ul style="list-style-type: none"> <li>• Bottom seal (draught excluder)</li> </ul>
<p>Bolts for fire doors</p>	<p>3 passive SC-Firebolts in galvanized steel 3 active SC-Firebolts in galvanized steel</p>
<p>Hinges</p>	<p>5 concealed hinges adjustable on 3 axes, painted silver. Possible adjustments:</p> <ul style="list-style-type: none"> <li>• Vertical adjustment <math>\pm 2</math> mm</li> <li>• Pressure adjustment <math>\pm 1</math> mm</li> <li>• Horizontal adjustment <math>\pm 1.5</math> mm</li> </ul>

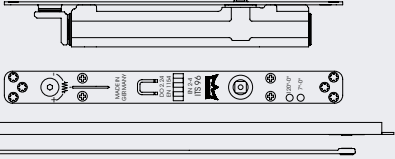
# Essential Swing EI 30/60 (X122)

<p>Door closer</p>	<p>Incorporated Dorma ITS 96 EN 2-4. Door closer with cam operation incorporated into the door, CE-marked in compliance with the EN 1154 A standard, with rapid opening/force torque decrease. Variable closing force, closing speed and latching action.</p> 
<p>Closure type</p>	 <p>Lock: A. E70 F22 safety lock B. Opera SL E70 F22 (without anti-intrusion protection) C. Opera DQ SL E70 F22</p>
<p>Lock and electric strike plate finish</p>	<ul style="list-style-type: none"> <li>• Mat chrome</li> </ul>
<p>Lock operation descriptions</p>	<p>SL safety lock, backset 70 mm, faceplate 22 mm. Conventional lock with latch and bolt operated by a cylinder with a DIN V 18254 profile. The lever latch ensures the maximum silence of door closure, particularly when an automatic door closer is also fitted. The lock is CE-marked in compliance with the EN 12209:2003/AC:2005 standard, and is therefore certified for use on smoke and fire doors. Handles with through screws cannot be fitted.</p>
	<p>Opera Hotel SL, backset 70 mm, faceplate 22 mm, without anti-intrusion protection. Panic lock for hotel and community doors. When the handle is lowered from the inside, the latch and lock are immediately released, allowing a rapid exit to be made from the room in case of an emergency. The OPERA SL lock allows any type of handle to be used. The occupancy indicator is in fact linked directly to the cylinder. Can be used only with an OPERA cylinder with limited rotation. When an electric strike plate is fitted, door opening can be automated using a badge and transponder. The lock is CE-marked in compliance with the EN 12209:2003/AC:2005 standard, and is therefore certified for use on smoke and fire doors.</p>
	<p>Opera hotel DQ SL, backset 70 mm, faceplate 22 mm (lock with only one panic side). Insertable panic lock hotel and community doors (healthcare centres, hospitality structures for the elderly and holidaymakers, bathrooms, common entrances in public buildings, where use of the handle from both sides of the door is preferred or necessary). When the handle is lowered from the inside, the latch and lock are immediately released, allowing a rapid exit to be made from the room in case of an emergency. When the handle is lowered on the panic side, the latch and bolt retract into the lock. From the opposite side, lowering the handle retracts only the latch. To be used only with an OPERA cylinder with complete rotation. When the specific electric strike plate is fitted, door opening can be automated using a badge and transponder. The lock is CE-marked in compliance with the EN 12209:2003/AC:2005 standard, and is therefore certified for use on smoke and fire doors.</p>
<p>Strike plate on frame (valid for safety locks and Opera locks)</p>	<p>Lock Strike plate with adjustable recess (can be electrified subsequently). Use Opera panic locks and SL safety locks are fitted with a normal strike plate that can later be converted into an electric strike plate by replacing the recess with an electrical unit. Cannot be combined with Opera locks with anti-intrusion protection.</p>
<p>Electrical unit</p>	<p>Electrical unit 12V. 250 V AC/ DC 280 mA, 24 V AC 500 V/ DC 560 mA, without opening memory, without manual release lever.</p>
<p>Packaging composition</p>	<p>Composed of two packages:  <ul style="list-style-type: none"> <li>• frame package</li> <li>• door panel package</li> </ul> All accessories, including hinges, seals, door closer, Firebolts and lock, are supplied inside the frame package, and must be fitted when the door is installed.</p>

# Essential Battente Zero

## Essential Swing Zero

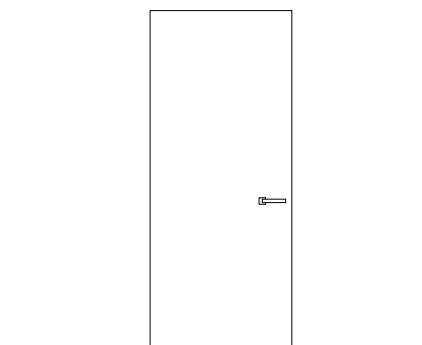
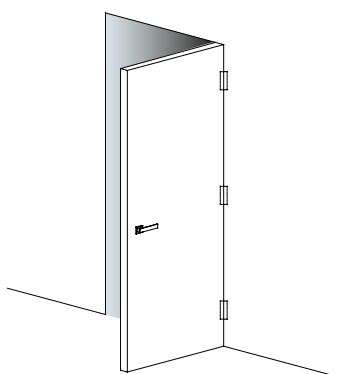

Luce di passaggio Clear opening size		Misura d'ingombro Structural opening size		Spessore parete Finished wall
L	H	Li	Hi	Sp
600	2000/2100	730	2065/2165	105 Intonaco 100 Cartongesso
700		830		
750		880		
800		930		
900		1030		

### Legenda Legend

- L = Larghezza luce  
Opening Width
- H = Altezza luce  
Opening Height
- Li = Ingombro in larghezza  
Overall Width
- Hi = Ingombro in altezza  
Overall Height
- Sp = Spessore parete  
Finished Wall

Nota: La fornitura comprende solo la serratura magnetica con chiave patent. Telaio e porta non vendibili separatamente.  
Note: The supply includes only the magnetic lock with "patent" key. Frame and door are not sold separately.

La versione a spingere consente l'apertura massima dell'anta di 90°/100°, con conseguente riduzione della luce di passaggio.  
The push model allows the maximum opening of the leaf of 90° / 100°, with the consequent reduction of the clear opening size.

### Modello a Tirare / Pull model

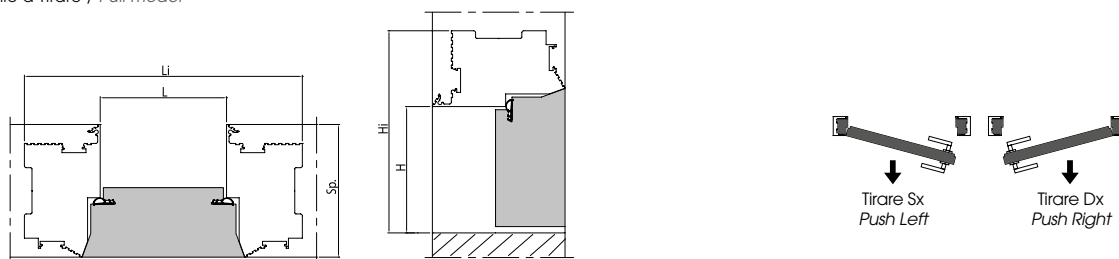

### Modello a Spingere / Push model

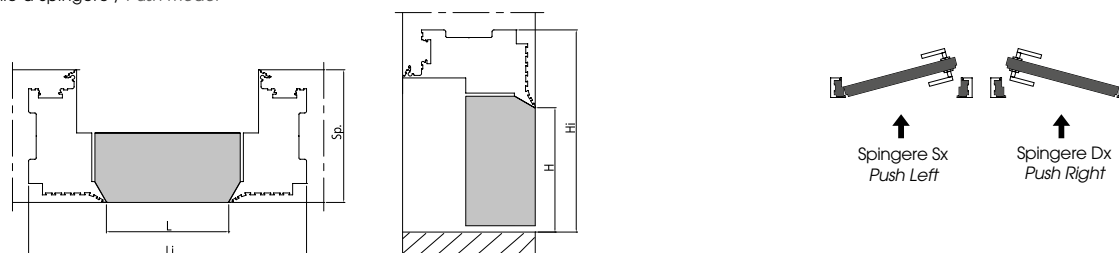

In caso di affiancamento di porte a spingere e a tirare sulla stessa parete, fra i due modelli, a parità di luce di passaggio, il foro luce del modello Tirare presenta una differenza di altezza di + 10 mm e in larghezza di + 20 mm.

In case of Push and Pull doors one beside the other on the same wall, between the two models with the same clear opening size, the light hole for the Pull model presents a difference of + 10 mm for the height and of + 20 mm for the width.

# Essential Battente Zero

## Essential Swing Zero

Essential Battente Zero per parete Intonaco 105 mm e cartogesso 100 mm - modello a Tirare.  
 Essential Battente Zero Swing door, pull model, for masonry thickness 105 mm and for plasterboard 100 mm.

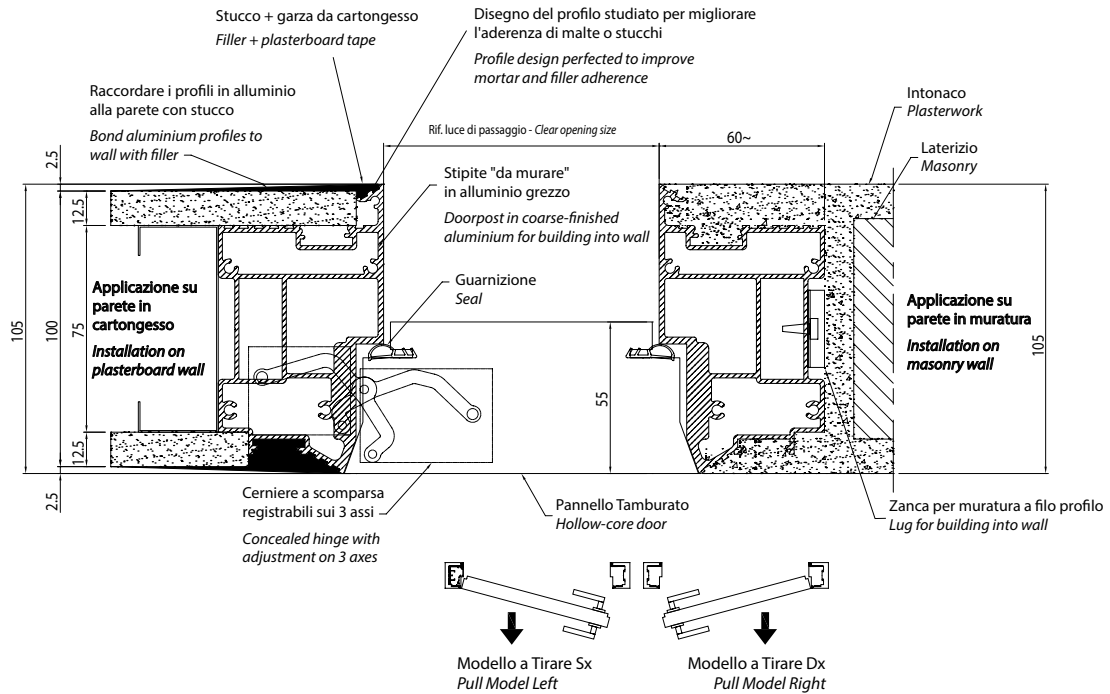

Essential Battente per parete Intonaco 105 mm e cartogesso 100 mm- modello a Spingere.  
 Essential Zero Swing door, push model, for masonry thickness 105 mm and for plasterboard 100 mm.

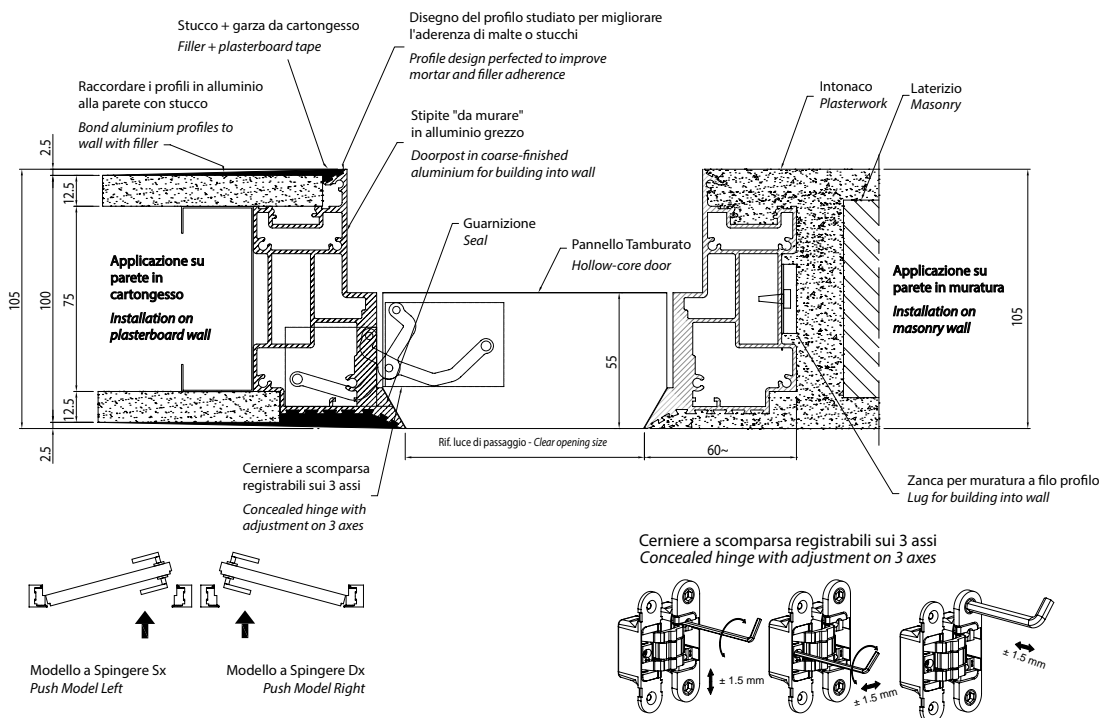

# Essential Little 1 anta • Apertura laterale

## Essential Little with side • Opening 1 door

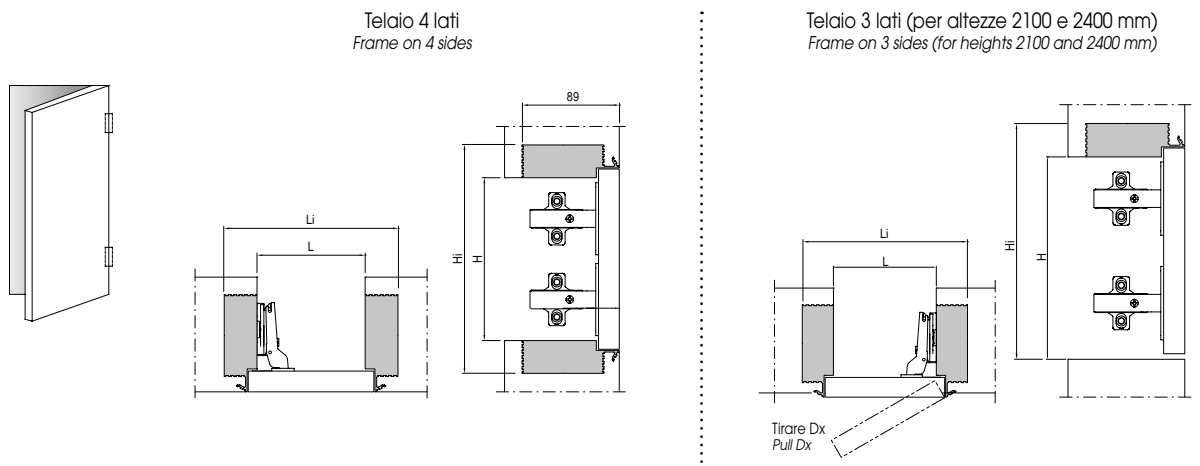

### Standard

Vano Opening dimensions		Telaio Frame dimensions		Vano Opening dimensions		Telaio Frame dimensions	
L	H	Li	Hi	L	H	Li	Hi
600	400	470	470	600	400	670	470
	600		670				
	800		870				
	1000		1070				
	1200		1270				
	1500		1570				
	1800		1870				
	*2100		*2135				
*2400	*2435						

\* H=2100 e 2400 Telaio in alluminio su 3 lati con anta tirare a DX  
For the High 2100 and 2400 mm aluminium frame on three sides with opening right pull.

### Fuori misura

Vano Opening dimensions		Telaio Frame dimensions	
L	H	Li	Hi
300 ÷ 600	300 ÷ 1500	370 ÷ 670	370 ÷ 1570

Serrature disponibili:

Push Lock pomolo bianco - Push Lock pomolo cromato opaco - Push Lock pomolo cromato lucido.

Serratura a leva con spina triangolare - Serratura a leva con cilindro - Premi/Apri.

Locking availables: white Push Lock, satin chrome Push Lock, polished chrome Push lock, cam lock for triangular socket key, cam locks with cylinder, push to open.

# Essential Little 2 ante • Apertura laterale

## Essential Little with side • Opening 2 doors

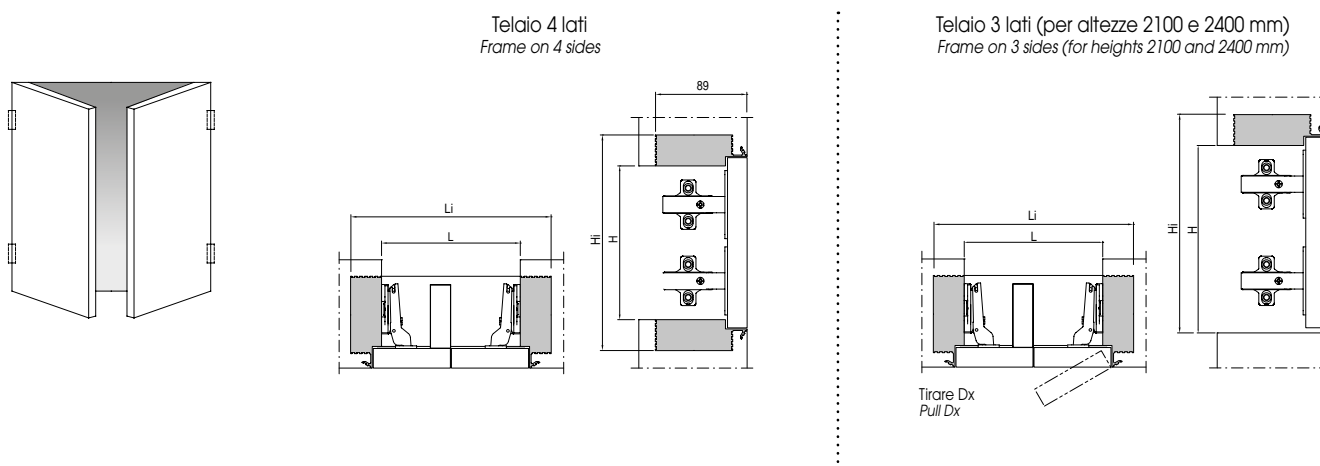

### Standard Standard

Vano Opening dimensions		Telaio Frame dimensions		Vano Opening dimensions		Telaio Frame dimensions	
L	H	Li	Hi	L	H	Li	Hi
816	400	886	470	1216	400	1286	470
	600		670		600		670
	800		870		800		870
	1000		1070		1000		1070
	1200		1270		1200		1270
	1500		1570		1500		1570
	1800		1870		1800		1870
	*2100		*2135		*2100		*2135
	*2400		*2435		*2400		*2435

\* H=2100 e 2400 Telaio in alluminio su 3 lati con anta tirare a DX  
For the High 2100 and 2400 mm aluminium frame on three sides with opening right pull.

### Fuori misura Extra Height

Vano Opening dimensions		Telaio Frame dimensions	
L	H	Li	Hi
600 ÷ 1200	300 ÷ 1500	670 ÷ 1270	370 ÷ 1570

Serrature disponibili:

Push Lock pomolo bianco - Push Lock pomolo cromato opaco - Push Lock pomolo cromato lucido.

Serratura a leva con spina triangolare - Serratura a leva con cilindro - Premi/Apri.

Locking availables: white Push Lock, satin chrome Push Lock, polished chrome Push lock, cam lock for triangular socket key, cam locks with cylinder, push to open.

# Essential Little 1 anta • Apertura orizzontale

*Essential Little with horizontal • Opening 1 door*

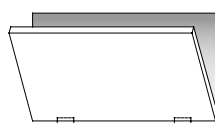

Apertura a ribalta  
Upwards opening

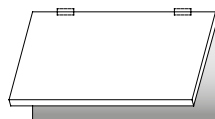

Apertura a vasistas  
Downwards opening

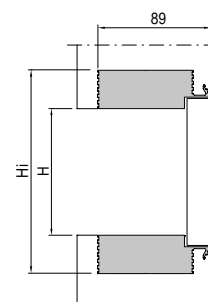
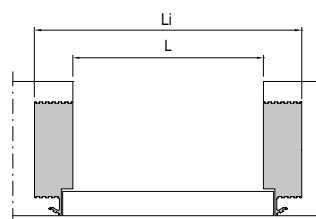

Vano Opening dimensions		Telaio Frame dimensions	
L	H	Li	Hi
300 ÷ 1500	300 ÷ 600	370 ÷ 1570	370 ÷ 670

**Serrature disponibili:**

Push Lock pomolo bianco - Push Lock pomolo cromato opaco - Push Lock pomolo cromato lucido.

Serratura a leva con spina triangolare - Serratura a leva con cilindro.

*Locking availables: white Push Lock, satin chrome Push Lock, polished chrome Push lock, cam lock for triangular socket key, cam locks with cylinder.*



# Essential Little Zero 1 anta • Apertura laterale

*Essential Little Zero with side • Opening 1 door*

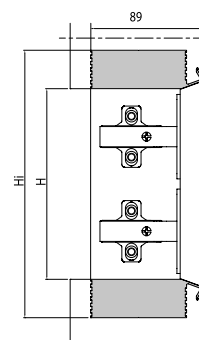
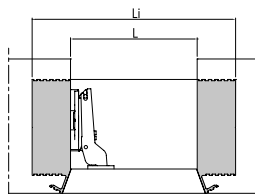
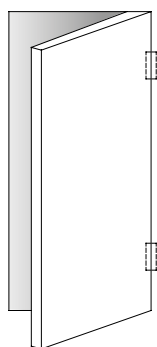

Vano <i>Opening dimensions</i>		Telaio <i>Frame dimensions</i>	
L	H	Li	Hi
300 ÷ 600	300 ÷ 1300	370 ÷ 670	370 ÷ 1370

# Essential Little Zero 1 anta • Apertura orizzontale

*Essential Little Zero with horizontal • Opening 1 door*

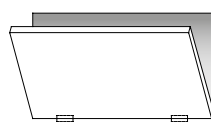

Apertura a ribalta  
*Upwards opening*

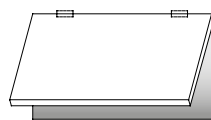

Apertura a vasistas  
*Downwards opening*

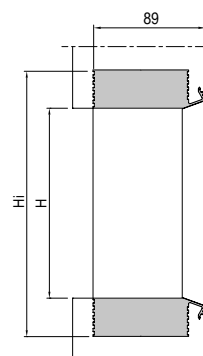
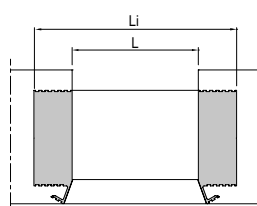

Vano <i>Opening dimensions</i>		Telaio <i>Frame dimensions</i>	
L	H	Li	Hi
300 ÷ 1300	300 ÷ 600	370 ÷ 1370	370 ÷ 670

Serrature disponibili:

Push Lock pomolo bianco - Push Lock pomolo cromato opaco - Push Lock pomolo cromato lucido.

Serratura a leva con spina triangolare - Serratura a leva con cilindro - Premi/Apri.

Locking available: white Push Lock, satin chrome Push Lock, polished chrome Push lock, cam lock for triangular socket key, cam locks with cylinder, push to open.

# Essential Little Zero

## Essential Little - Sportello a 1 anta apertura laterale Essential Little Single door with side opening

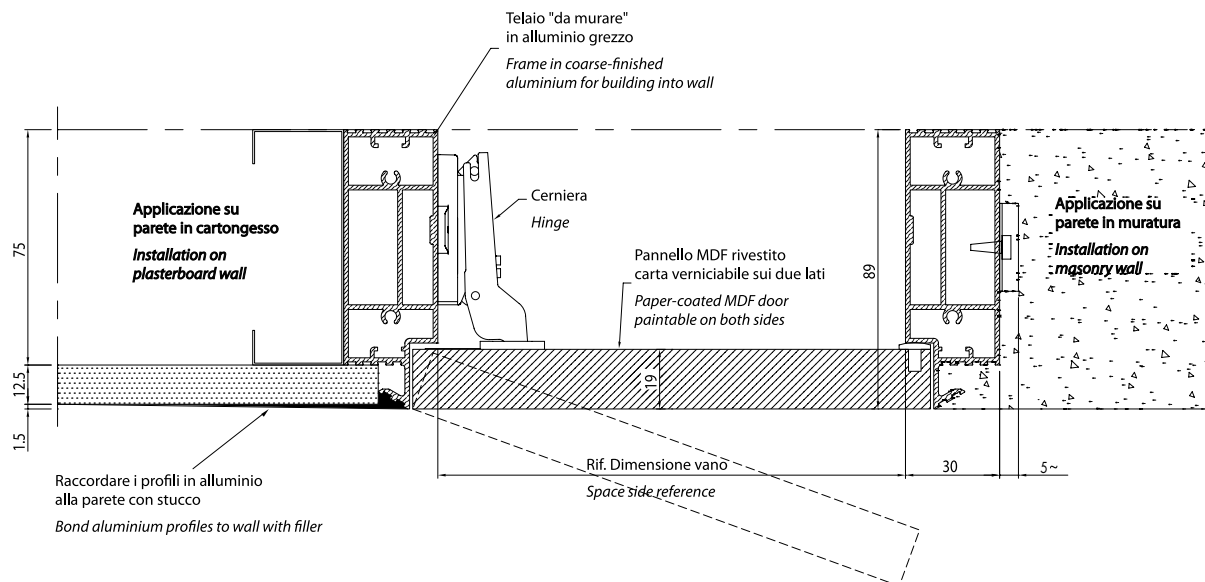

## Essential Little Zero - Sportello a 1 anta apertura laterale Essential Little Zero Single door with side opening

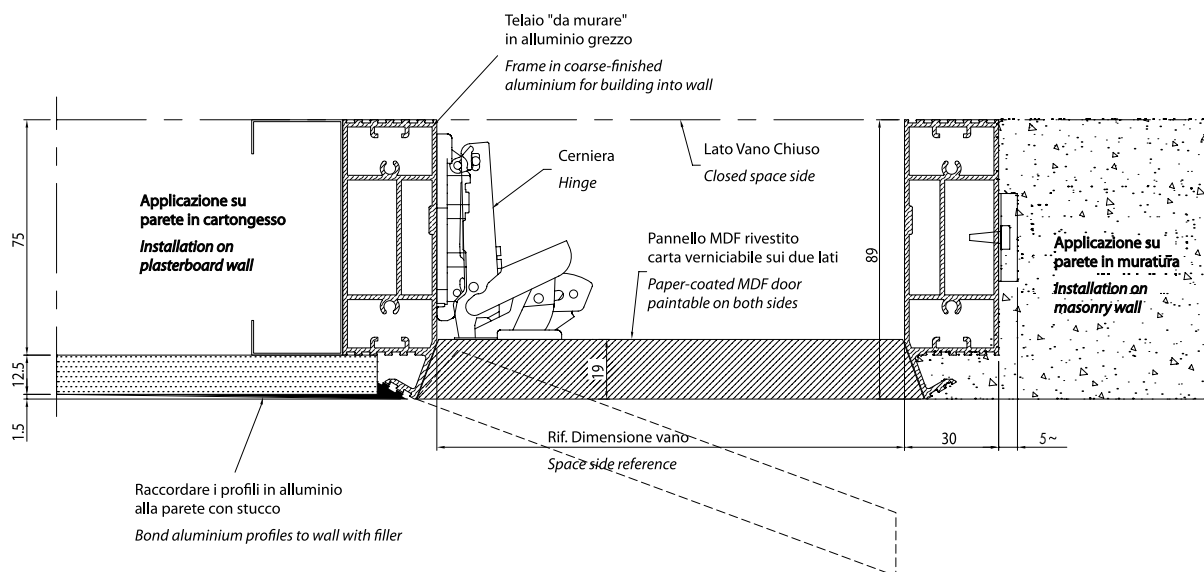

# Essential Little Cartongesso

## Essential Little Plasterboard



### Essential Little Cartongesso da soffitto

Essential Little Plasterboard for ceiling

Vano Opening dimensions		Telaio Frame dimensions	
L	H	Li	Hi
200	200		
300	300	600	600
400	400		
500	500	800	800
600	600		

Nota: apertura a spinta verso l'interno del soffitto.  
Note: push opening towards the inside of the ceiling.

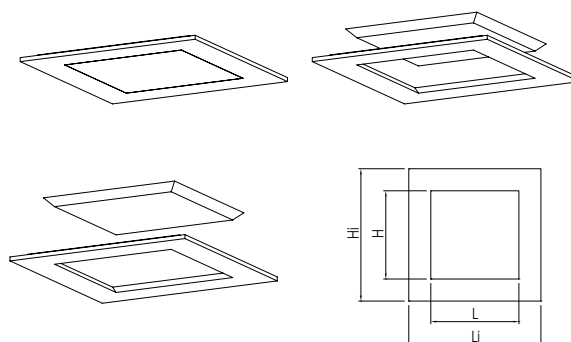

### Essential little Cartongesso da parete a fissaggio magnetico

Essential Little Plasterboard for wall, fixed magnetically

Vano Opening dimensions		Telaio Frame dimensions	
L	H	Li	Hi
200	200	600	600
400	600	600	800
1600	300	2000	600

Nota: maniglia in dotazione  
Note: handle provided

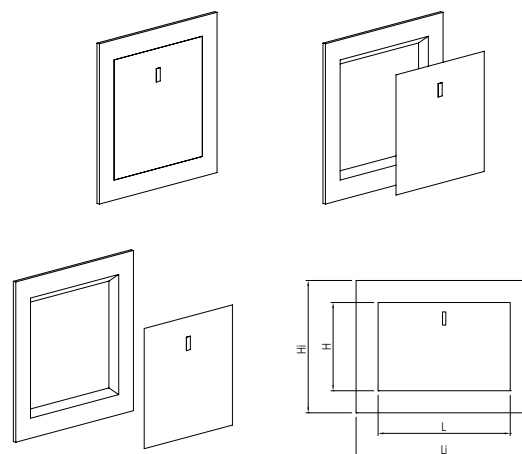

Tutti i modelli Essential Little Cartongesso presentano bordi conici, pertanto la luce di passaggio effettiva è ridotta di circa 15 mm per ogni lato.  
All Essential Little drywall models have edges, so the real clear opening size is reduced by approximately 15 mm on each side.

# Essential Little Cartongesso

## Essential Little Plasterboard

Essential Little Cartongesso da parete con cerniere - 1 anta  
 Essential Little plasterboard for wall, with hinge - 1 door

Vano Opening dimensions		Telaio Frame dimensions	
L	H	Li	Hi
300	400	600	800
400	600		
500	1000	800	1300

Nota: maniglia con nottolino asportabile in dotazione  
 Note: handle with removable lock provided

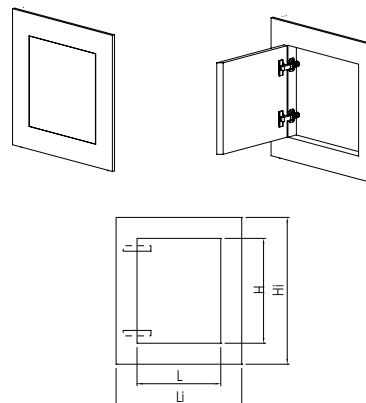

Essential Little Cartongesso da parete con cerniere - 2 ante  
 Essential Little plasterboard for wall, with hinge - 2 doors

Vano Opening dimensions		Telaio Frame dimensions	
L	H	Li	Hi
800	1500	1200	2000

Nota: maniglia con nottolino asportabile in dotazione  
 Note: handle with removable lock provided

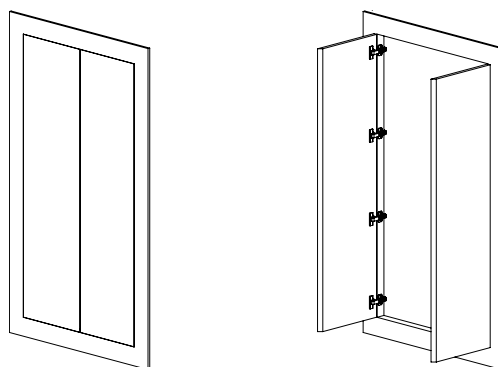
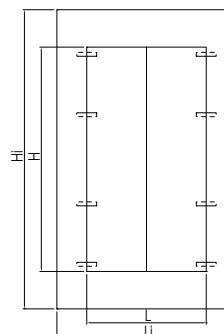

Tutti i modelli Essential Little Cartongesso presentano bordi conici, pertanto la luce di passaggio effettiva è ridotta di circa 15 mm per ogni lato.  
 All Essential Little drywall models have edges, so the real clear opening size is reduced by approximately 15 mm on each side.

# Essential Little Cartongesso

## Essential Little Plasterboard

Essential Little Cartongesso - Botola da soffitto.  
Essential Little hatch for plasterboard ceiling.

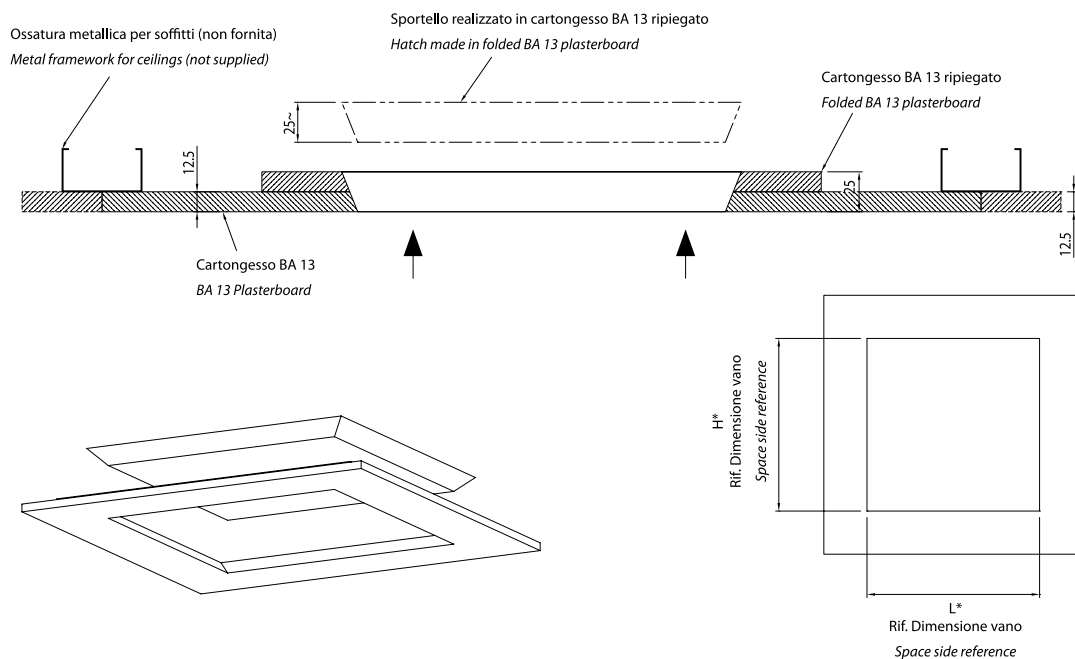

Essential Little Cartongesso - Botola da parete a fissaggio magnetico.  
Essential Little plasterboard wall hatch with magnetic catch.

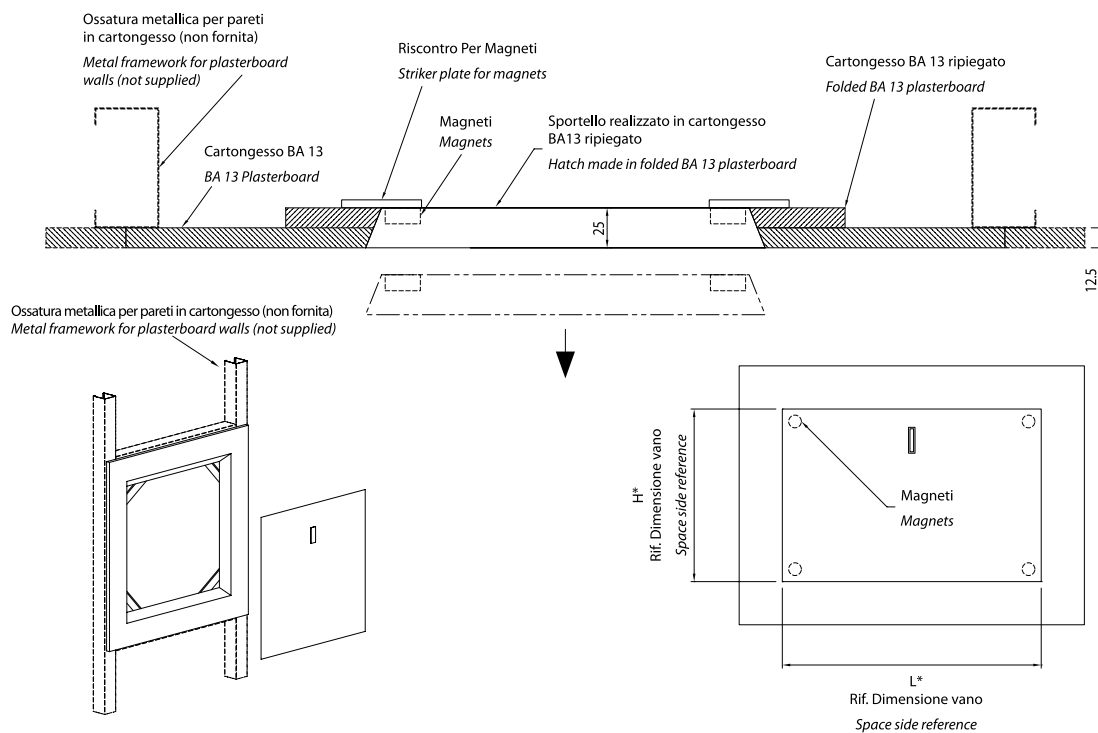

Tutti i modelli Essential Little Cartongesso presentano bordi conici, pertanto la luce di passaggio effettiva è ridotta di circa 15 mm per ogni lato.  
All Essential Little drywall models have edges, so the real clear opening size is reduced by approximately 15 mm on each side.

# Essential Little Cartongesso

## Essential Little Plasterboard

Essential Little Cartongesso - Sportello a 1 anta da parete e apertura laterale con cerniere.  
 Essential Little single plasterboard wall hatch, side opening with hinge.

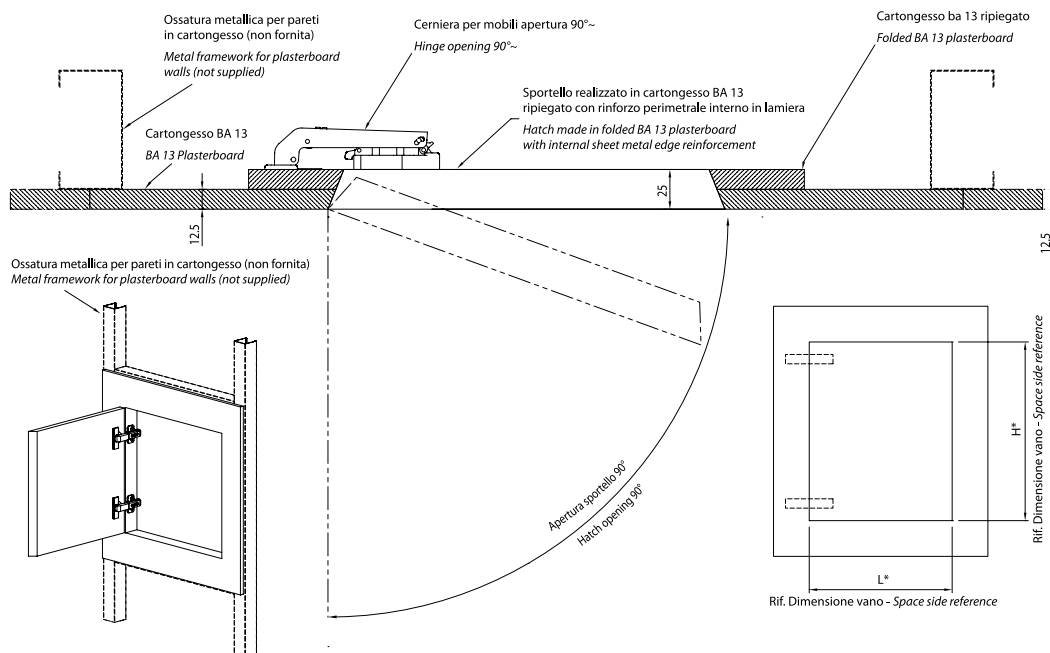

Essential Little Cartongesso - Sportello a 2 ante da parete e apertura laterale con cerniere.  
 Essential Little double plasterboard wall hatch, side opening with hinges.

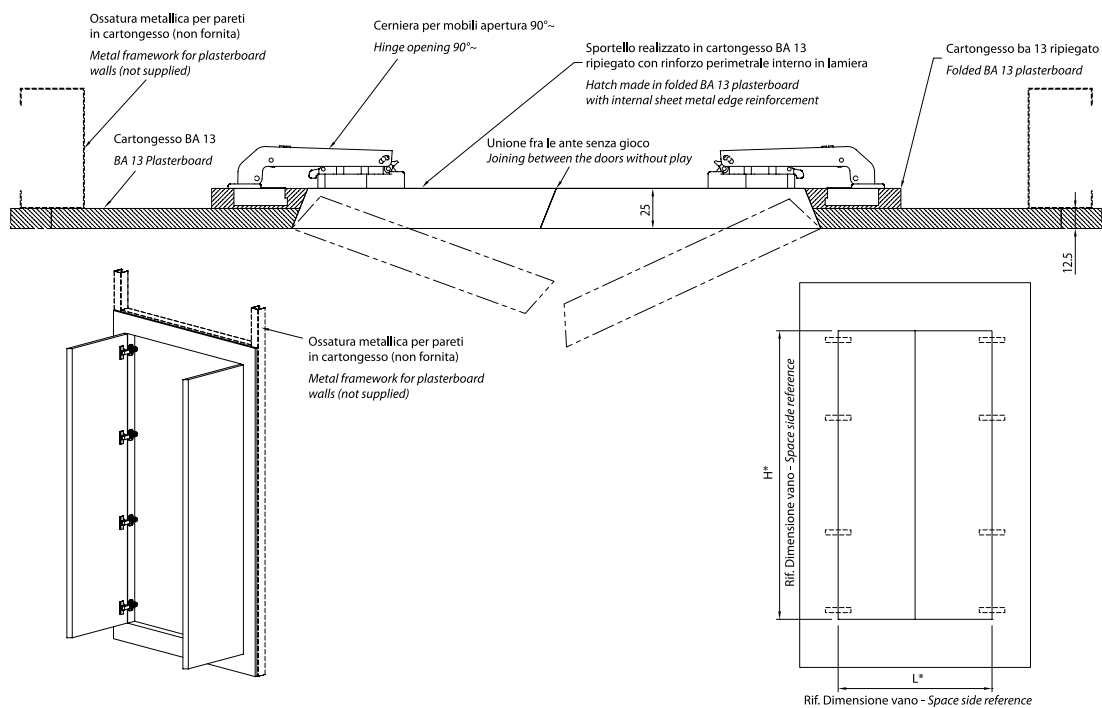

Tutti i modelli Essential Little Cartongesso presentano bordi conici, pertanto la luce di passaggio effettiva è ridotta di circa 15 mm per ogni lato.  
 All Essential Little drywall models have edges, so the real clear opening size is reduced by approximately 15 mm on each side.



Dettagli tecnici porte  
*Technical details doors*

---

152 Porte Comfort / *Comfort doors*

160 Porte Trésor / *Trésor doors*

187 Soluzioni vetro / *Glass solutions*

---

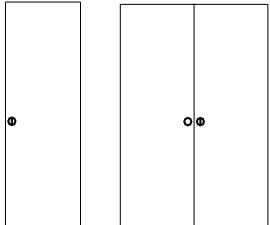
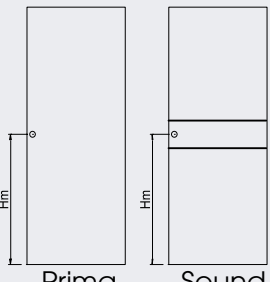
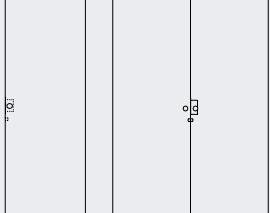
<p>Porte Comfort</p>	<p><b>Scorrevole per Essential</b></p> <p>Porta scorrevole tamburata, telaio in abete giuntato e anima in carta a nido d'ape a cella esagonale, placcata con pannello di fibra di legno MDF (Medium Density Fiberboard) nobilitato in superficie con decorativo melaminico. Bordi in abs da 10/10. Anta spessore 40 mm con venatura orizzontale sui piani e verticale sui bordi. Predisposta per l'inserimento delle speciali staffe di sospensione essential.</p>
<p>Versioni</p>	 <p>Dimensione pannello L+15 e H-5 (es. luce 800 x 2100 mm pannello da 815 x 2095 mm).</p>
<p>Modelli</p>	 <ul style="list-style-type: none"> <li>• Prima pannello cieco spessore 40 mm con bordi da 10/10</li> <li>• Sound pannello cieco spessore 40 mm con 2 inserti in alluminio.</li> </ul> <p><b>Le misure in pronta consegna sono predisposte con il foro maniglia con serratura.</b></p> <p>Altezza maniglia:</p> <ul style="list-style-type: none"> <li>• luce 2100 mm Hm=1047</li> <li>• luce 2000 mm Hm=997</li> </ul>
<p>Tipologia stipite</p>	<p>Il prodotto non necessita di stipite</p>
<p>Dimensioni Standard</p>	<ul style="list-style-type: none"> <li>• Anta singola luce 600 - 700 - 750 - 800 - 900 - 1000 mm, altezza da 1910 a 2100 mm passo 1 mm.</li> <li>• Anta doppia luce 1200 - 1400 - 1600 - 1800 - 2000 mm, altezza da 1910 a 2100 mm passo 1 mm.</li> </ul>
<p>Finiture</p>	<ul style="list-style-type: none"> <li>• Bianco</li> <li>• Venato Bianco</li> <li>• Palissandro Bianco</li> <li>• Rovere</li> <li>• Rovere antracite</li> </ul>
<p>Spessore parete</p>	<ul style="list-style-type: none"> <li>• Installabile su essential scorrevole, qualsiasi spessore parete previsto a listino</li> </ul>
<p>Finiture accessori (compresi nella fornitura)</p>	<ul style="list-style-type: none"> <li>• Predisposizione foro maniglia a richiesta</li> <li>• Fresate per inserimento staffe Essential</li> <li>• Fresata inferiore per nasello guida</li> </ul>
<p>Tipologia chiusura</p>	 <p>Solo predisposizione per kit chiudiscigno:</p> <ul style="list-style-type: none"> <li>• con serratura</li> <li>• senza serratura</li> <li>• cilindro Europeo</li> <li>• nessun foro</li> </ul> <p>Serratura e maniglia non fornita.</p>

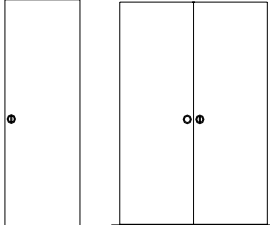
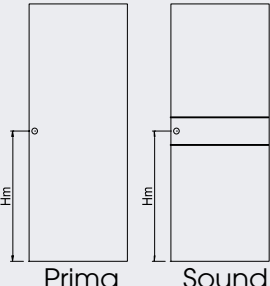
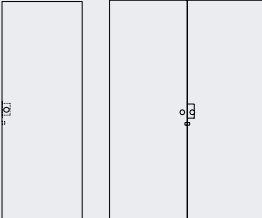
<p>Comfort doors</p>	<p><b>Sliding door for Essential</b></p> <p>Sliding hollow-core door with jointed fir frame and paper honeycomb core with hexagonal cells, covered with panels of wood fibreboard or medium density fibreboard (MDF) with a decorative melamine finish. Edges in 1 mm ABS.</p> <p>Door thickness 40 mm with horizontal grain on panels and vertical grain on edges. Pre-fitted for insertion of special suspension brackets for Essential.</p>
<p>Versions</p>	 <p>Panel dimensions L+15 and H+5 (e.g. opening size 800x2100 mm, door 815x2095 mm).</p>
<p>Models</p>	 <ul style="list-style-type: none"> <li>• Prima full panel, thickness 40 mm with 1 mm edges</li> <li>• Sound full panel, thickness 40 mm with 2 aluminium inserts Sizes in stock for immediate delivery are pre-mortised with a hole for a handle with lock.</li> </ul> <p>Handle height:</p> <ul style="list-style-type: none"> <li>• opening size 2100 Hm = 1047</li> <li>• opening size 2000 Hm = 997</li> </ul>
<p>Doorpost typology</p>	<p>This product requires no doorpost</p>
<p>Standard dimensions</p>	<ul style="list-style-type: none"> <li>• Single door opening size 600 – 700 – 750 – 800 – 900 – 1000 mm, height 1910 and 2100 mm, in steps of 1 mm</li> <li>• Double door opening size 1200 – 1400 – 1600 – 1800 – 2000 mm, height 1910 and 2100 mm, in steps of 1 mm</li> </ul>
<p>Finishes</p>	<ul style="list-style-type: none"> <li>• White</li> <li>• Veined White</li> <li>• White rosewood</li> <li>• Oak</li> <li>• Anthracite oak</li> </ul>
<p>Wall thickness</p>	<ul style="list-style-type: none"> <li>• Can be installed on Essential sliding frames for any wall thickness indicated in the price list</li> </ul>
<p>Accessory finishes (included)</p>	<ul style="list-style-type: none"> <li>• Pre-mortised hole for handle on request</li> <li>• Machined recesses for insertion of Essential brackets</li> <li>• Machined groove for floor guide</li> </ul>
<p>Closure typology</p>	 <p>Lock and handle not supplied.</p> <p>Pre-mortised only for Chiodiscrigno Kit:</p> <ul style="list-style-type: none"> <li>• with lock</li> <li>• without lock</li> <li>• European cylinder</li> <li>• without hole</li> </ul>

# Porta Scorrevole Comfort modello Prima e Sound per Essential

## Comfort Sliding door Prima and Sound model for Essential

Singola  
Single

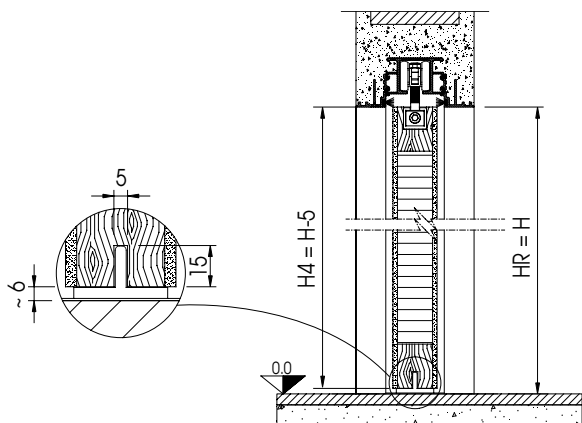

Eseguire sempre il rilievo misure prima di ordinare la porta  
Always take measurements before ordering the door

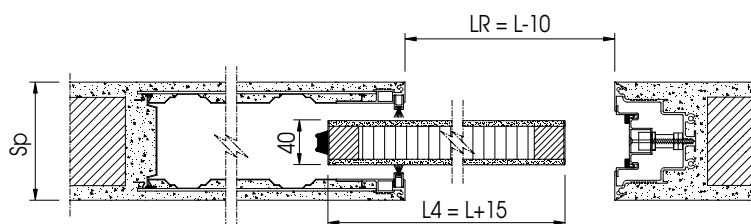

 MDF
  ABETE GIUNTATO JOINTED FIR
  STRUTTURA ALVEOLARE A NIDO D'APE HONEYCOMB HOLLOW-CORE STRUCTURE

Luce di passaggio Clear opening size L x H	Luce reale Effective opening dimensions LR x HR	Misura anta Door measurement L4 x H4	Spessore parete Finished wall Sp
600 x 1910 ÷ 2100	590 x 1910 ÷ 2100	615 x 1905 / 2095	Intonaco Plastered 105 - 125 - 145
700 x 1910 ÷ 2100	690 x 1910 ÷ 2100	715 x 1905 / 2095	
750 x 1910 ÷ 2100	740 x 1910 ÷ 2100	755 x 1905 / 2095	
800 x 1910 ÷ 2100	790 x 1910 ÷ 2100	815 x 1095 / 2095	Cartongesso Plasterboard 100 - 125
900 x 1910 ÷ 2100	890 x 1910 ÷ 2100	915 x 1905 / 2095	
1000 x 1910 ÷ 2100	990 x 1910 ÷ 2100	1015 x 1905 / 2095	

# Porta Scorrevole Comfort modello Prima e Sound per Essential

## Comfort Sliding door Prima and Sound model for Essential

Doppia  
Double

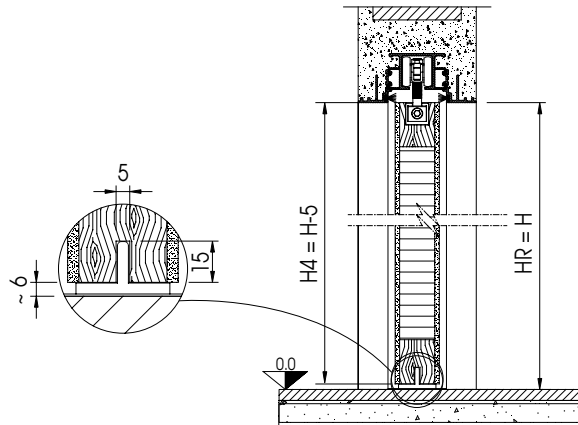

Eseguire sempre il rilievo misure prima di ordinare la porta  
Always take measurements before ordering the door

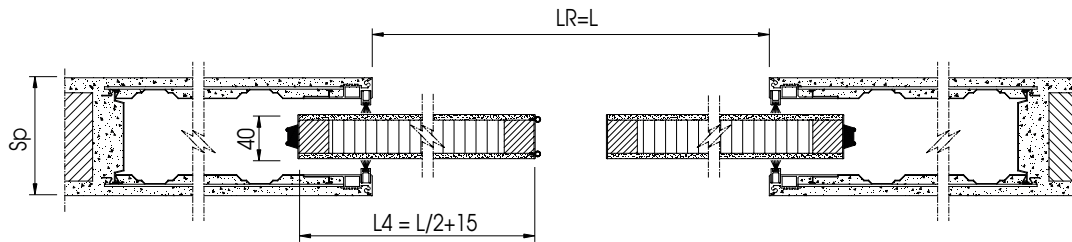

 MDF    
  ABETE GIUNTATO JOINTED FIR    
  STRUTTURA ALVEOLARE A NIDO D'APE HONEYCOMB HOLLOW-CORE STRUCTURE

Luce di passaggio <i>Clear opening size</i> L x H	Luce reale <i>Effective opening dimensions</i> LR x HR	Misura anta <i>Door measurement</i> L4 x H4	Spessore parete <i>Finished wall</i> Sp
1200 x 1910 ÷ 2100	1200 x 1910 ÷ 2100	615 x 1905 / 2095	Intonaco <i>Plastered</i> 105 - 125 - 145
1400 x 1910 ÷ 2100	1400 x 1910 ÷ 2100	715 x 1905 / 2095	
1600 x 1910 ÷ 2100	1600 x 1910 ÷ 2100	815 x 1905 / 2095	
1800 x 1910 ÷ 2100	1800 x 1910 ÷ 2100	915 x 1905 / 2095	Cartongesso <i>Plasterboard</i> 100 - 125
2000 x 1910 ÷ 2100	2000 x 1910 ÷ 2100	1015 x 1905 / 2095	

# Predisposizione maniglie per porte Comfort Scorrevole

## *Handles pre-arranged for Sliding Comfort doors*

Singola  
*Single*

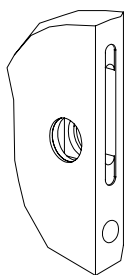
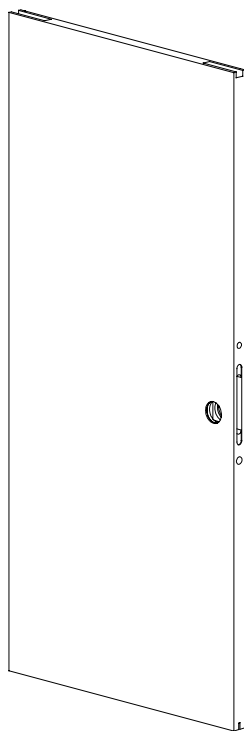

Anta predisposta con foro per  
kit Chiudiscigno con serratura o  
con chiave pieghevole  
*Door pre-mortised with recess for  
Chiudiscigno Kit with lock or with  
folding key*

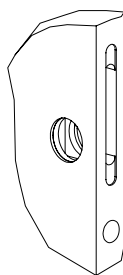

Anta predisposta con foro per  
kit Chiudiscigno con serratura o  
con cilindro europeo  
*Door pre-mortised with recess for  
Chiudiscigno Kit with lock or with  
European cylinder*

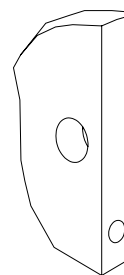

Anta predisposta con foro per  
kit Chiudiscigno senza serratura  
*Door pre-mortised with recess for  
Chiudiscigno Kit without lock*

# Predisposizione maniglie per porte Comfort Scorrevole

## *Handles pre-arranged for Sliding Comfort doors*

Doppia  
*Double*

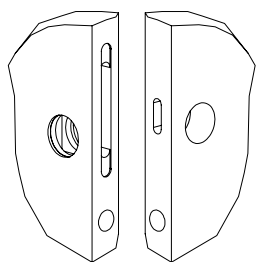
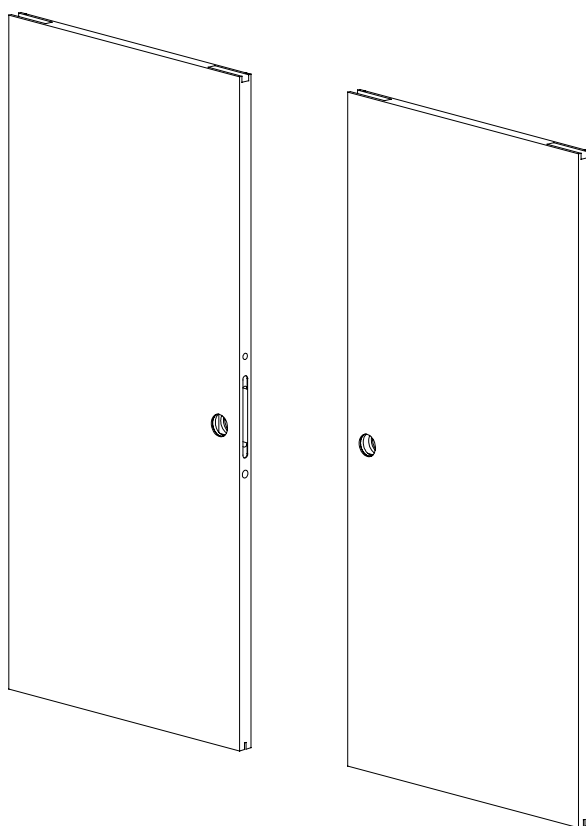

Anta predisposta con foro per  
kit Chiudiscigno con serratura o  
con chiave pieghevole

*Door pre-mortised with recess for  
Chiudiscigno Kit with lock or with  
folding key*

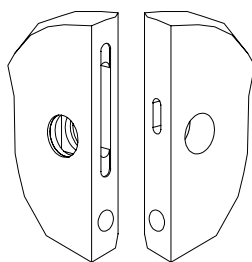

Anta predisposta con foro per  
kit Chiudiscigno con serratura o  
con cilindro europeo

*Door pre-mortised with recess for  
Chiudiscigno Kit with lock or with  
European cylinder*

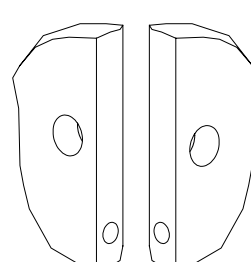

Anta predisposta con foro per  
kit Chiudiscigno senza serratura

*Door pre-mortised with recess for  
Chiudiscigno Kit without lock*



Porte Trésor  
*Trésor doors*

# Composizione porte

Porte Trésor
Versioni
Modelli
Tipologia stipite
Dimensioni Standard
Finiture
Spessore parete
Finiture accessori (compresi nella fornitura)
Tipologia chiusura

## Scorrevole per Essential

Porta scorrevole tamburata, telaio in abete giuntato o massello di toulipier/frassino e anima in carta a nido d'ape a cella esagonale, placcata con pannello di fibra di legno MDF (Medium Density Fiberboard) nobilitato in superficie tranciato di frassino per la finitura frassino laccato.

Anta spessore 40 mm con venatura orizzontale sui piani e verticale sui bordi per la finitura frassino laccato.

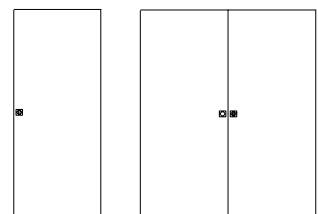

Versione:

- Anta singola
- Anta doppia

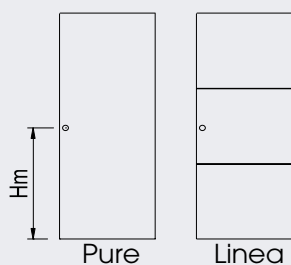

- Pure pannello cieco spessore 40 mm
- Linea pannello cieco spessore 40 mm con 2 piccole fresate laccate come la porta

Altezza maniglia:

- Hm=1030

Il prodotto non necessita di stipite

- Anta singola luce da 600 a 1200\* mm • altezza da 1800 a 2700 mm
- Anta doppia luce da 1200 a 2400\* mm • altezza da 1800 a 2700 mm
- \* per parete 100 cartongesso dimensione massima 1000 per anta singola e 2000 per il doppia anta, altezza massima 2100 mm.

- Frassino a poro aperto laccato opaco
- Laccato opaco
- Laccato Lucido
- Colori standard RAL1013/1015/9001/9002/9003/9010/9016/9018
- A richiesta è disponibile tutta la gamma di colori RAL.

- Si installa su essential scorrevole, qualsiasi spessore parete previsto a listino

- Predisposizione foro maniglia a richiesta
- Fresate per inserimento staffe essential
- Fresata inferiore per nasello guida
- Asta raddrizzante interna al pannello per altezza superiore a 2200 mm

Solo predisposizione (foratura) per kit chiudiscritto:

- con serratura
  - senza serratura
  - cilindro europeo
  - foro vaschetta
  - maniglia ricavata con incasso
  - nessun foro
- Maniglia e serratura fornite su richiesta.

Trésor  
doors

Versions

Models

Doorpost  
typology

Standard  
dimensions

Finishes

Wall  
thickness

Accessory  
finishes  
(included)

Closure  
typology

## Sliding door for Essential

Sliding hollow-core door, with frame in jointed fir or solid tulipwood/ash and paper honeycomb core with hexagonal cells, covered with panels of wood fibreboard or medium density fibreboard (MDF) with a decorative ash veneer surface for the lacquered ash finish.  
Door thickness 40 mm with horizontal grain on panels and vertical grain on edges for the lacquered ash finish.

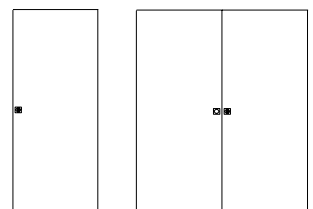

Version:

- Single door
- Double door

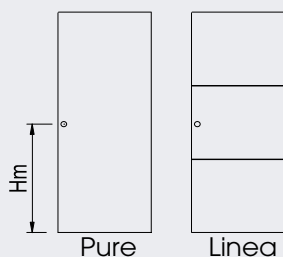

- Pure full panel, thickness 40 mm
- Linea full panel, thickness 40 mm with 2 small machined grooves, lacquered like the door

Handle height:

- Hm = 1030

This product requires no doorpost

- Single door opening size 600 to 1200\* mm, height from 1800 to 2700 mm
- Double door opening size 1200 to 2400\* mm, height from 1800 to 2700 mm
- \* For 100 plasterboard walls, maximum dimension 1000 for single doors and 2000 for double doors

- Open-pore ash with matt lacquer
  - Matt Lacquer
  - Gloss lacquer
- Standard RAL colours 1013/1015/9001/9002/9003/9010/9016/9018  
The entire range of RAL colours is available on request

- Can be installed on Essential sliding frames for any wall thickness indicated in the price list

- Pre-mortised hole for handle on request
- Machined recesses for insertion of Essential brackets
- Machined groove for floor guide
- Straightener rod inside door for heights over 2200 mm

Pre-mortised only for Chiudiscigno Kit:

- with lock
  - without lock
  - European cylinder
  - mortised for recessed handles
  - inset handle with mortise
  - without hole
- Handle and lock supplied on request.

# Porta Scorrevole Trésor modello Pure e Linea per Essential

## Trésor Sliding door Pure and Linea model for Essential

Singola  
Single

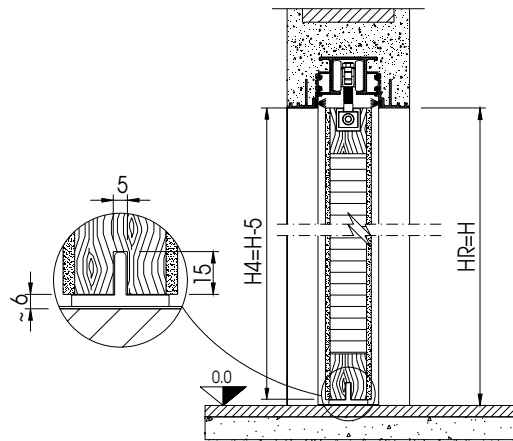

Eeguire sempre il rilievo misure prima di ordinare la porta  
Always take measurements before ordering the door

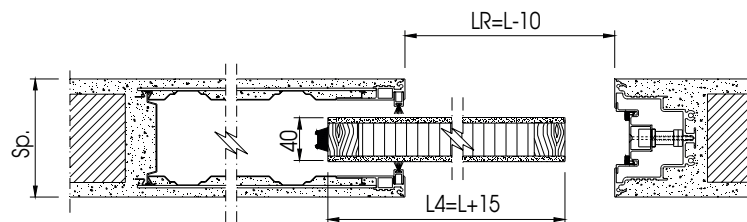

MDF ABETE GIUNTATO JOINTED FIR STRUTTURA ALVEOLARE A NIDO D'APE HONEYCOMB HOLLOW-CORE STRUCTURE

Luce di passaggio Clear opening size L x H	Luce reale Effective opening dimensions LR x HR	Misura anta Door measurement L4 x H4	Spessore parete Finished wall Sp
600 x 1800 ÷ 2700	590 x 1800 ÷ 2700	615 x 1795 ÷ 2695	Intonaco Plastered 105 - 125 - 145
700 x 1800 ÷ 2700	690 x 1800 ÷ 2700	715 x 1795 ÷ 2695	
750 x 1800 ÷ 2700	740 x 1800 ÷ 2700	755 x 1795 ÷ 2695	
800 x 1800 ÷ 2700	790 x 1800 ÷ 2700	815 x 1795 ÷ 2695	Cartongesso Plasterboard 100* - 125 *H massima 2100 *maximum height 2100
900 x 1800 ÷ 2700	890 x 1800 ÷ 2700	915 x 1795 ÷ 2695	
1000 x 1800 ÷ 2700	990 x 1800 ÷ 2700	1015 x 1795 ÷ 2695	
*1100 x 1800 ÷ 2700	1090 x 1800 ÷ 2700	1115 x 1795 ÷ 2695	
*1200 x 1800 ÷ 2700	1190 x 1800 ÷ 2700	1215 x 1795 ÷ 2695	

\* Solo per spessore parete 105 - 125 • Only for walls thickness 105 - 125 - 145

# Porta Scorrevole Trésor modello Pure e Linea per Essential

## Trésor Sliding door Pure and Linea model for Essential

Doppia  
Double

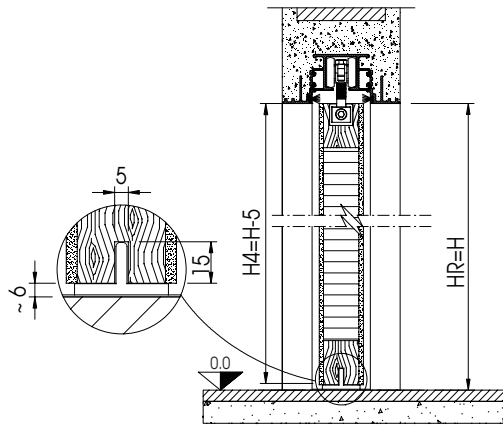

Eseguire sempre il rilievo misure prima di ordinare la porta  
Always take measurements before ordering the door

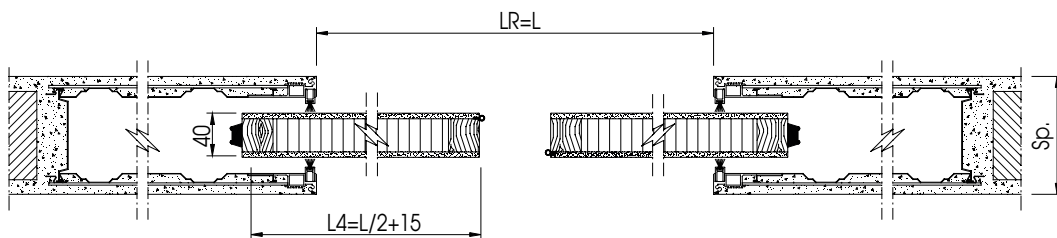

 MDF    
  ABETE GIUNTATO JOINTED FIR    
  STRUTTURA ALVEOLARE A NIDO D'APE HONEYCOMB HOLLOW-CORE STRUCTURE

Luce di passaggio Clear opening size L x H	Luce reale Effective opening dimensions LR x HR	Misura anta Door measurement L4 x H4	Spessore parete Finished wall Sp
1200 x 1800 ÷ 2700	1200 x 1800 ÷ 2700	615 x 1795 ÷ 2695	Intonaco Plastered 105 - 125 - 145
1400 x 1800 ÷ 2700	1400 x 1800 ÷ 2700	715 x 1795 ÷ 2695	
1600 x 1800 ÷ 2700	1600 x 1800 ÷ 2700	815 x 1795 ÷ 2695	
1800 x 1800 ÷ 2700	1800 x 1800 ÷ 2700	915 x 1795 ÷ 2695	Cartongesso Plasterboard 100* - 125 *H massima 2100 *maximum height 2100
2000 x 1800 ÷ 2700	2000 x 1800 ÷ 2700	1015 x 1795 ÷ 2695	
*2200 x 1800 ÷ 2700	*2200 x 1800 ÷ 2700	1115 x 1795 ÷ 2695	
*2400 x 1800 ÷ 2700	*2400 x 1800 ÷ 2700	1215 x 1795 ÷ 2695	

\* Solo per spessore parete 105 - 125 • Only for walls thickness 105 - 125 - 145

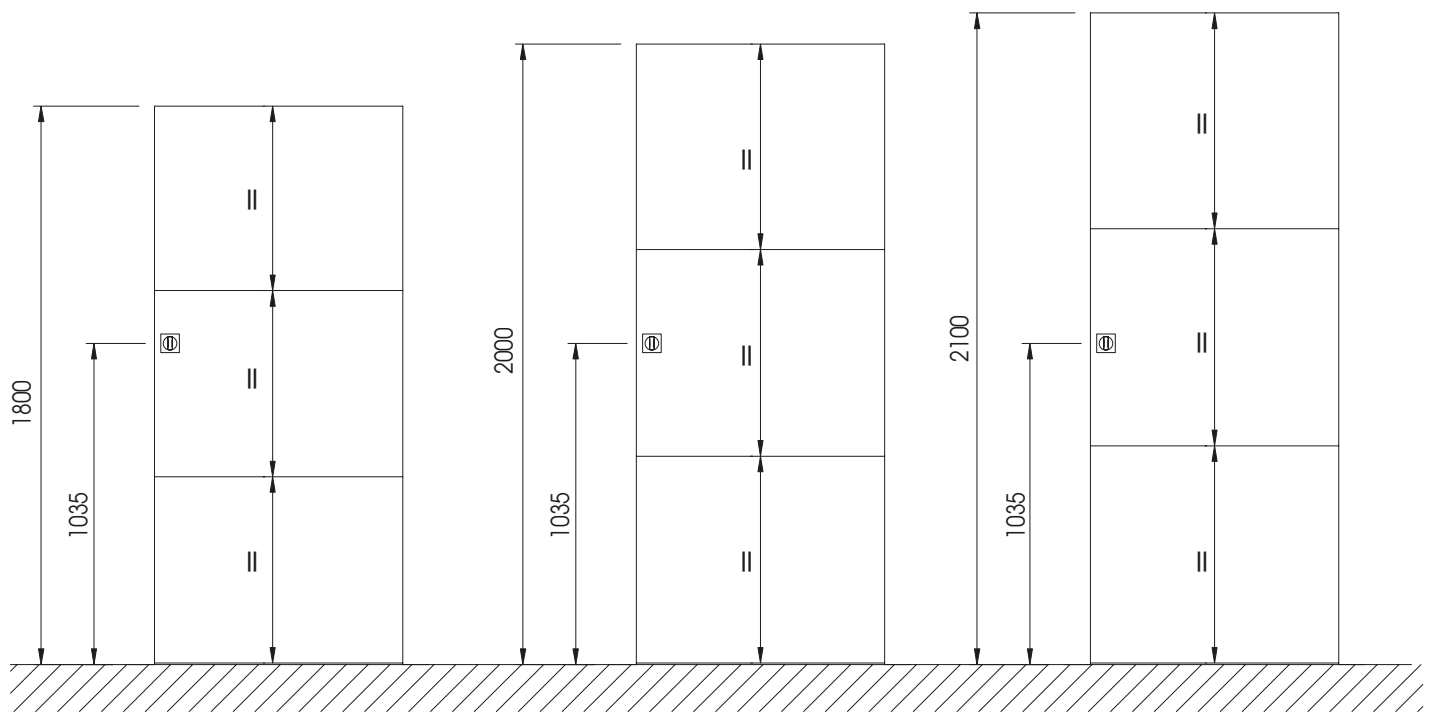

■ *Position of machined recesses on Trésor doors for Linea model*

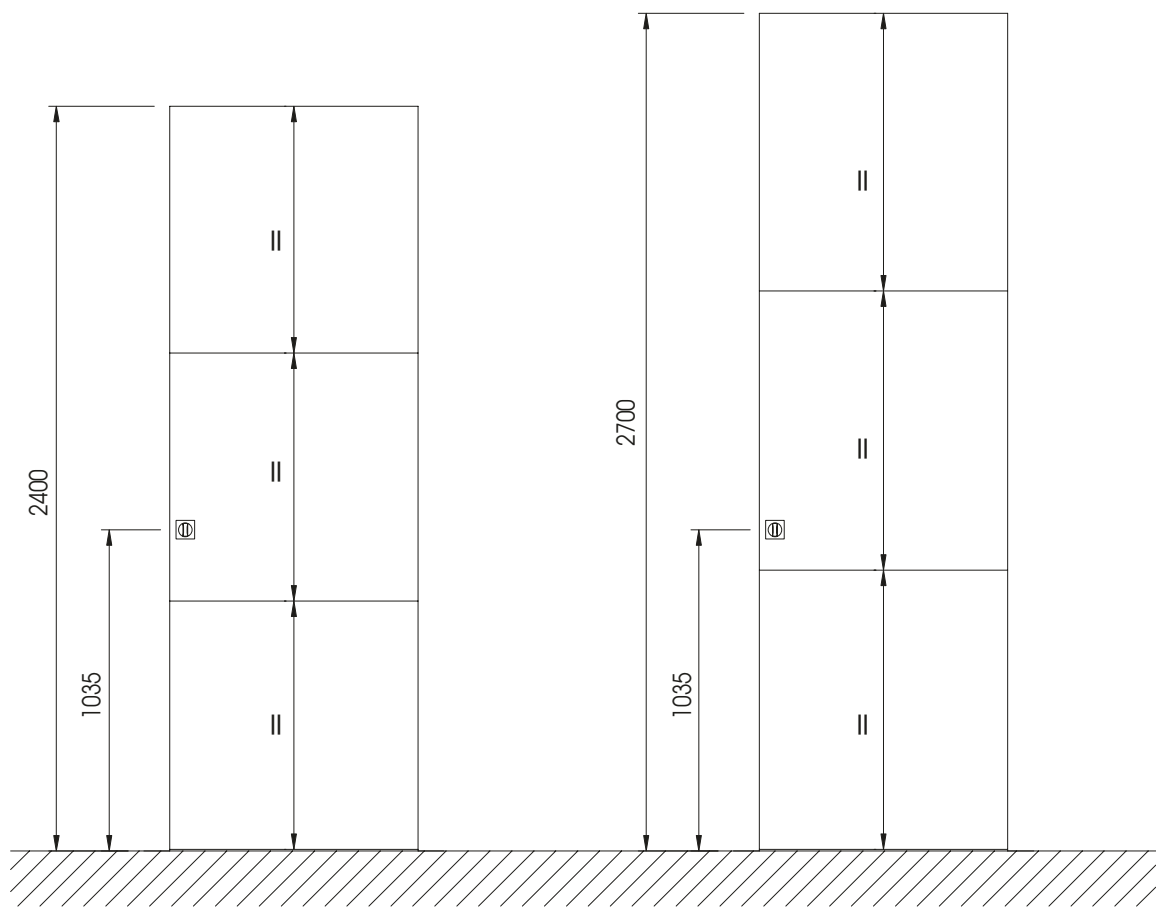









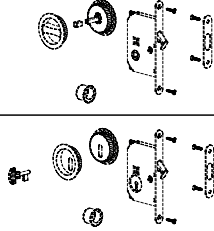

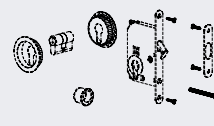

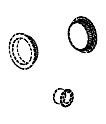

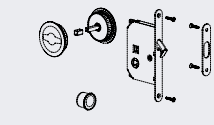
# Predisposizione maniglie per porte Trésor Scorrevole

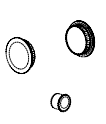
## Handles pre-arranged for Sliding Trésor doors

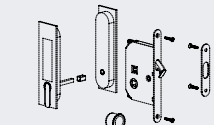
### Singola

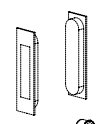
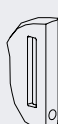
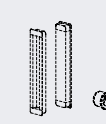
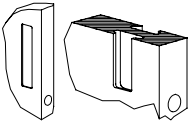
#### Single

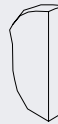



Scelta lavorazione maniglia Choice of machining for handle	Predisposizione Machining	Maniglia da ordinare Handle to be ordered
<p>Predisposizione kit CHIUDISCRIGNO con serratura o con chiave pieghevole.</p> <p><i>Pre-mortised for CHIUDISCRIGNO Kit with lock or with folding key.</i></p>		
<p>Predisposizione kit CHIUDISCRIGNO con cilindro europeo.</p> <p><i>Pre-mortised for CHIUDISCRIGNO Kit with European lock.</i></p>		
<p>Predisposizione kit CHIUDISCRIGNO senza serratura.</p> <p><i>Pre-mortised for CHIUDISCRIGNO Kit without lock.</i></p>		
<p>Predisposizione Kit CHIUDISCRIGNO SEGNO Tonda o Quadra con serratura</p> <p><i>Pre-mortised for Kit CHIUDISCRIGNO SIGN Rund or Square with lock.</i></p>		
<p>Predisposizione Kit Chiudiscigno SEGNO Tonda o Quadra senza con serratura</p> <p><i>Pre-mortised for CHIUDISCRIGNO SIGN Rund or Square without lock.</i></p>		
<p>Predisposizione Kit CHIUDISCRIGNO SEGNO Rettangolare con serratura</p> <p><i>Pre-mortised for Kit CHIUDISCRIGNO SIGN Rectangular with lock.</i></p>		
<p>Predisposizione Kit CHIUDISCRIGNO SEGNO Rettangolare senza serratura</p> <p><i>Pre-mortised for Kit CHIUDISCRIGNO SIGN Rectangular without lock.</i></p>		
<p>Predisposizione foro Vaschetta.</p> <p><i>Pre-mortised for recessed handle.</i></p>		
<p>* Maniglia ricavata con incasso. Disponibile solo per le ante laccate opache o con il solo fondo.</p> <p>* <i>Mortised for inset handle. Available for matt lacquer finishes or with primer only.</i></p>		
<p>Nessuna lavorazione.</p> <p><i>Without machining.</i></p>		

\* Non disponibile nei laccati lucidi e frassinati • *Not available in gloss lacquered or ash finishes*

# Predisposizione maniglie per porte Trésor Scorrevole

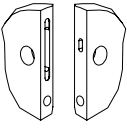
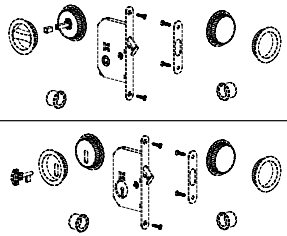
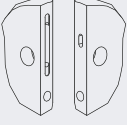
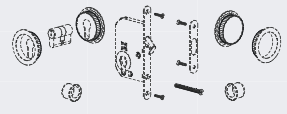
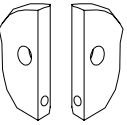
## Handles pre-arranged for Sliding Trésor doors

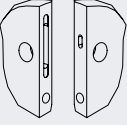
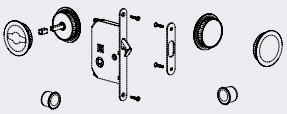
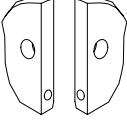
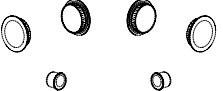
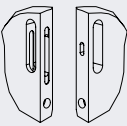
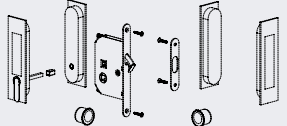
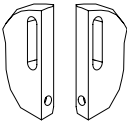
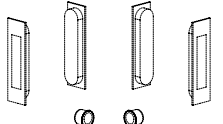
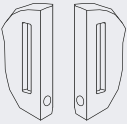
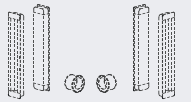
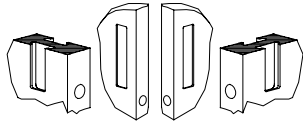
Doppia  
Double

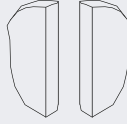
Scelta lavorazione maniglia Choice of machining for handle	Predisposizione Machining	Maniglia da ordinare Handle to be ordered
<p>Predisposizione kit CHIUDISCRIGNO con serratura o con chiave pieghevole.</p> <p><i>Pre-mortised for CHIUDISCRIGNO Kit with lock or with folding key.</i></p>		
<p>Predisposizione kit CHIUDISCRIGNO con cilindro europeo.</p> <p><i>Pre-mortised for CHIUDISCRIGNO Kit with European lock.</i></p>		
<p>Predisposizione kit CHIUDISCRIGNO senza serratura.</p> <p><i>Pre-mortised for CHIUDISCRIGNO Kit without lock.</i></p>		
<p>Predisposizione Kit CHIUDISCRIGNO SEGNO Tonda o Quadra con serratura</p> <p><i>Pre-mortised for Kit CHIUDISCRIGNO SIGN Rund or Square with lock.</i></p>		
<p>Predisposizione Kit Chiudiscigno SEGNO Tonda o Quadra senza con serratura</p> <p><i>Pre-mortised for CHIUDISCRIGNO SIGN Rund or Square without lock.</i></p>		
<p>Predisposizione Kit CHIUDISCRIGNO SEGNO Rettangolare con serratura</p> <p><i>Pre-mortised for Kit CHIUDISCRIGNO SIGN Rectangular with lock.</i></p>		
<p>Predisposizione Kit CHIUDISCRIGNO SEGNO Rettangolare senza serratura</p> <p><i>Pre-mortised for Kit CHIUDISCRIGNO SIGN Rectangular without lock.</i></p>		
<p>Predisposizione foro Vaschetta.</p> <p><i>Pre-mortised for recessed handle.</i></p>		
<p>* Maniglia ricavata con incasso. Disponibile solo per le ante laccate opache o con il solo fondo.</p> <p>* <i>Mortised for inset handle. Available for matt lacquer finishes or with primer only.</i></p>		
<p>Nessuna lavorazione.</p> <p><i>Without machinin.</i></p>		

\* Non disponibile nei laccati lucidi e frassinati • *Not available in gloss lacquered or ash finishes*

# Composizione porte

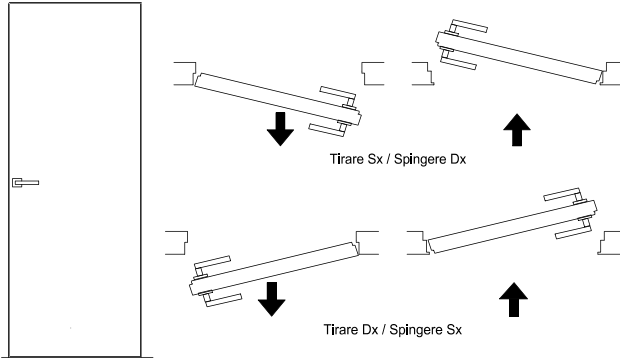
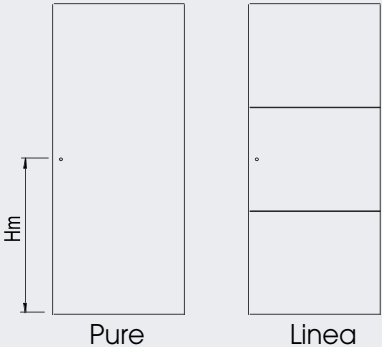
<p>Porte Trésor</p>	<p><b>Battente Essential anta unica (solo Anta)</b></p> <p>Porta tamburata con battuta su 3lati, telaio in abete giuntato o massello di toulprier/frassino e anima in carta a nido d'ape a cella esagonale, placcata con pannello di fibra di legno MDF (Medium Density Fiberboard) impiallacciato con tranciato di frassino naturale per la finitura frassino laccato. Anta spessore mm 55 con venatura orizzontale sui piani e verticale sui bordi per la finitura frassino laccato.</p>
<p>Versioni</p>	 <p>Versione:</p> <ul style="list-style-type: none"> <li>• Tirare destra/Spingere sinistra</li> <li>• Tirare sinistra/Spingere destra</li> </ul> <p>Nota : La versione a spingere consente l'apertura massima dell'anta di 90°/100°, con conseguente riduzione della luce di passaggio</p>
<p>Modelli</p>	 <ul style="list-style-type: none"> <li>• Pure pannello cieco spessore 55 mm</li> <li>• Linea pannello cieco spessore 55 mm con 2 piccole fresate laccate come la porta</li> </ul> <p>Altezza maniglia:</p> <ul style="list-style-type: none"> <li>• Hm=1035</li> </ul>
<p>Tipologia stipite</p>	<p>il prodotto non necessita di stipite</p>
<p>Dimensioni Standard</p>	<ul style="list-style-type: none"> <li>• Larghezza (in mm) da 600 a1000</li> <li>• Altezza (in mm) da 1800 a 2700</li> </ul>
<p>Finiture</p>	<ul style="list-style-type: none"> <li>• Frassino a poro aperto laccato opaco</li> <li>• Laccato opaco</li> <li>• Laccato Lucido</li> <li>• Fondo</li> </ul> <p>Colori standard RAL1013/1015/9001/9002/9003/9010/9016/9018 A richiesta è disponibile tutta la gamma di colori RAL</p>
<p>Spessore parete</p>	<ul style="list-style-type: none"> <li>• si installa su telaio essential battente, qualsiasi spessore parete previsto a listino</li> </ul>
<p>Finiture accessori (compresi nella fornitura)</p>	<ul style="list-style-type: none"> <li>• Lavorazioni cerniere, 3 fino a 2399, 4 da 2400.</li> <li>• Lavorazione serratura*</li> <li>• Fresata per guarnizione di battuta</li> <li>• Asta raddrizzate interna al pannello per altezze superiori a 2400</li> </ul> <p>* il foro chiave è realizzato solo su richiesta</p>
<p>Tipologia chiusura</p>	<p>Solo predisposizione (foratura) per :</p> <ul style="list-style-type: none"> <li>• serratura magnetica (chiave,quadro, cilindro)</li> <li>• serratura rullo</li> <li>• serratura rullo + foro vaschetta</li> <li>• serratura rullo con maniglia ricavata con incasso *</li> <li>• serratura con foro chiave per riscontro elettrico</li> </ul> <p>* Disponibile solo per le ante laccate opache o con fondo.</p>

### Battente Essential anta unica senza traverso (solo Anta)

Porta tamburata con battuta su 2 lati, telaio in abete giuntato o massello di toulipier/frassino e anima in carta a nido d'ape a cella esagonale, placcata con pannello di fibra di legno MDF (Medium Density Fiberboard) impiallaciato con tranciato di frassino naturale per la finitura frassino laccato.  
Anta spessore mm 55 con venatura orizzontale sui piani e verticale sui bordi per la finitura frassino laccato.

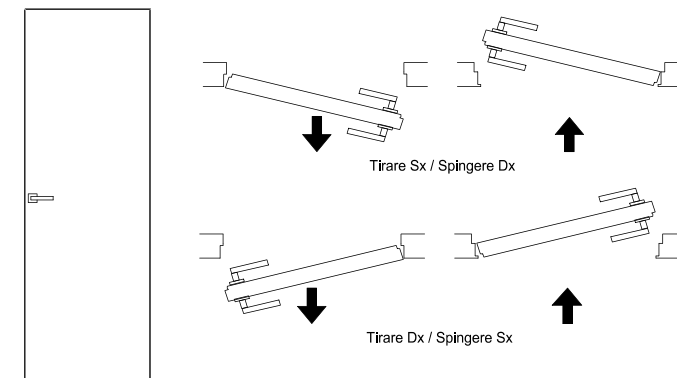

Versione:

- Tirare destra/Spingere sinistra
- Tirare sinistra/Spingere destra

Nota: La versione a spingere consente l'apertura massima dell'anta di 90°/100°, con conseguente riduzione della luce di passaggio

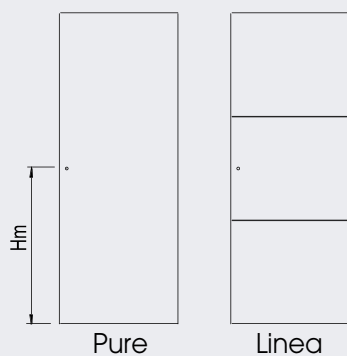

- Pure pannello cieco spessore 55 mm
- Linea pannello cieco spessore 55 mm con 2 piccole fresate laccate come la porta

Altezza maniglia:

- Hm=1030

il prodotto non necessita di stipite

- Larghezza (in mm) da 600 a 1000
- Altezza (in mm) da 1800 a 3000

- Frassino a poro aperto laccato opaco
- Laccato opaco
- Laccato Lucido
- Fondo

Colori standard RAL1013/1015/9001/9002/9003/9010/9016/9018

A richiesta è disponibile tutta la gamma di colori RAL

- si installa su telaio essential battente, qualsiasi spessore parete previsto a listino

- Lavorazioni cerniere, 3 fino altezza 2399, 4 da 2400.
- Lavorazione serratura\*
- Fresata per guarnizione di battuta
- Asta raddrizzate interna al pannello per altezze superiori a 2400
- \* il foro chiave è realizzato solo su richiesta

Solo predisposizione (foratura) per :

- serratura magnetica (chiave,quadro, cilindro)
- serratura rullo
- serratura rullo + foro vaschetta
- serratura rullo con maniglia ricavata con incasso \*
- serratura con foro chiave per riscontro elettrico
- predisposizione chiudiporta incassato

\* Disponibile solo per le ante laccate opache o con fondo.

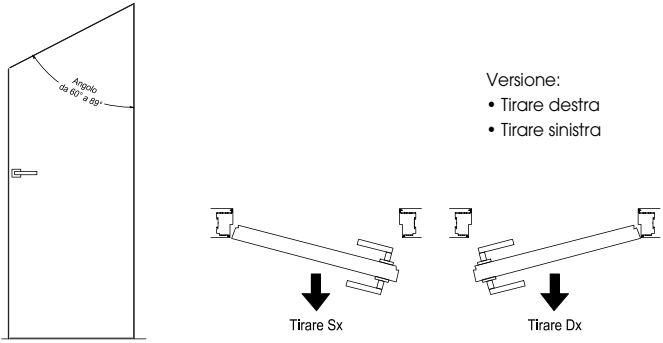
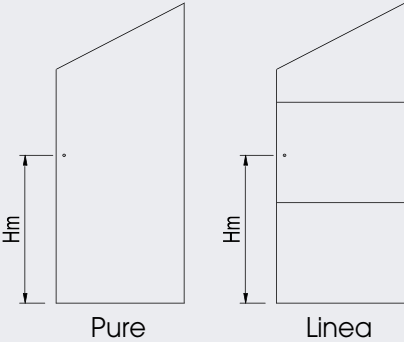
<p>Porte Trésor</p>	<p><b>Battente Essential anta unica trapezoidale (solo Anta)</b></p> <p>Porta tamburata con battuta su 3 lati, telaio in abete giuntato o massello di toulipier/frassino e anima in carta a nido d'ape a cella esagonale, placcata con pannello di fibra di legno MDF (Medium Density Fiberboard) impiallacciato con tranciato di frassino naturale per la finitura frassino laccato. Anta spessore 55 mm con venatura orizzontale sui piani e verticale sui bordi per la finitura frassino laccato.</p>
<p>Versioni</p>	 <p>Versione:</p> <ul style="list-style-type: none"> <li>• Tirare destra</li> <li>• Tirare sinistra</li> </ul>
<p>Modelli</p>	 <ul style="list-style-type: none"> <li>• Pure pannello cieco spessore 55 mm</li> <li>• Linea pannello cieco spessore 55 mm con 2 piccole fresate laccate come la porta</li> <li>• Vendita abbinata al telaio</li> </ul> <p>Altezza maniglia:</p> <ul style="list-style-type: none"> <li>• Hm=1035</li> </ul>
<p>Tipologia stipite</p>	<p>il prodotto non necessita di stipite</p>
<p>Dimensioni Standard</p>	<ul style="list-style-type: none"> <li>• Larghezza (in mm) da 600 a 1000</li> <li>• Altezza (in mm) da 1800 a 2700</li> </ul>
<p>Finiture</p>	<ul style="list-style-type: none"> <li>• Frassino a poro aperto laccato opaco</li> <li>• Laccato opaco</li> <li>• Laccato Lucido</li> <li>• Fondo</li> </ul> <p>Colori standard RAL1013/1015/9001/9002/9003/9010/9016/9018 A richiesta è disponibile tutta la gamma di colori RAL</p>
<p>Spessore parete</p>	<ul style="list-style-type: none"> <li>• si installa su telaio essential battente, qualsiasi spessore parete previsto a listino</li> </ul>
<p>Finiture accessori (compresi nella fornitura)</p>	<ul style="list-style-type: none"> <li>• Lavorazioni cerniere, 3 fino altezza 2399, 4 da 2400.</li> <li>• Lavorazione serratura*</li> <li>• Fresata per guarnizione di battuta</li> </ul> <p>* il foro chiave è realizzato solo su richiesta</p>
<p>Tipologia chiusura</p>	<p>Solo predisposizione (foratura) per:</p> <ul style="list-style-type: none"> <li>• serratura magnetica (chiave, quadro, cilindro)</li> <li>• serratura rullo</li> <li>• serratura rullo + foro vaschetta</li> <li>• serratura rullo con maniglia ricavata con incasso*</li> <li>• serratura con foro chiave per riscontro elettrico</li> </ul> <p>* Disponibile solo per le ante laccate opache o con fondo.</p>

## Battente Essential anta doppia (solo Anta)

Porta tamburata con battuta su 3lati, telaio in abete giuntato o massello di toulipier/frassino e anima in carta a nido d'ape a cella esagonale, placcata con pannello di fibra di legno MDF (Medium Density Fiberboard) impiallaciato con tranciato di frassino naturale per la finitura frassino laccato.

Anta spessore 55 mm con venatura orizzontale sui piani e verticale sui bordi per la finitura frassino laccato.

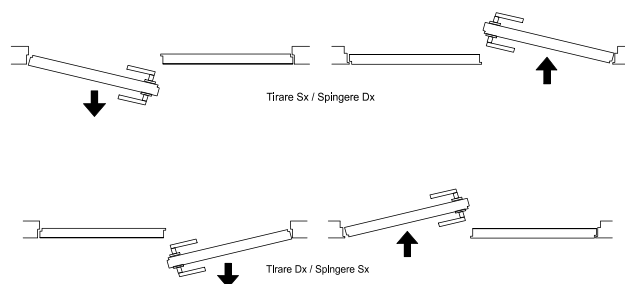
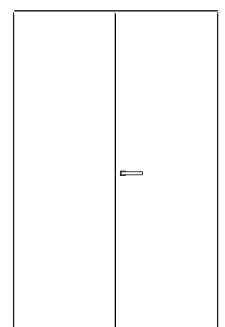

Versione:

- Tirare destra/Spingere sinistra
- Tirare sinistra/Spingere destra

Nota: La versione a spingere consente l'apertura massima dell'anta di 90°/100°, con conseguente riduzione della luce di passaggio

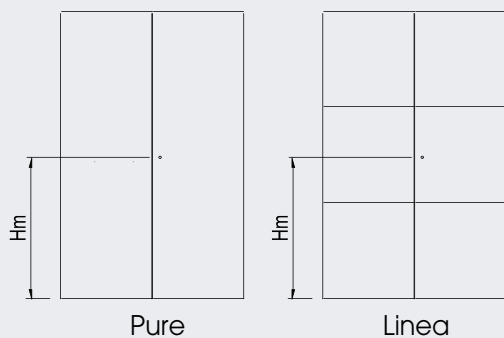

- Pure pannello cieco spessore 55 mm
- Linea pannello cieco spessore 55 mm con 2 piccole fresate laccate come la porta

Altezza maniglia:

- Hm=1035

il prodotto non necessita di stipite

- Larghezza (in mm) da 1200 a 1800
- Altezza (in mm) da 1800 a 2700

- Frassino a poro aperto laccato opaco
- Laccato opaco
- Laccato Lucido
- Fondo

Colori standard RAL1013/1015/9001/9002/9003/9010/9016/9018

A richiesta è disponibile tutta la gamma di colori RAL

- si installa su telaio essential battente, qualsiasi spessore parete previsto a listino

- Lavorazioni cerniere, 3 fino altezza 2399, 4 da 2400.
- Lavorazione serratura\*
- Fresata per guarnizione di battuta
- Fresata per catenacci su anta seconda anta
- Asta raddrizzate interna al pannello per altezze superiori a 2400
- \* il foro chiave è realizzato solo su richiesta

Solo predisposizione (foratura) per:

- serratura magnetica (chiave,quadro, cilindro)
- serratura rullo
- serratura rullo + foro vaschetta
- serratura rullo con maniglia ricavata con incasso\*
- serratura con foro chiave per riscontro elettrico

\* Disponibile solo per le ante laccate opache o con fondo.

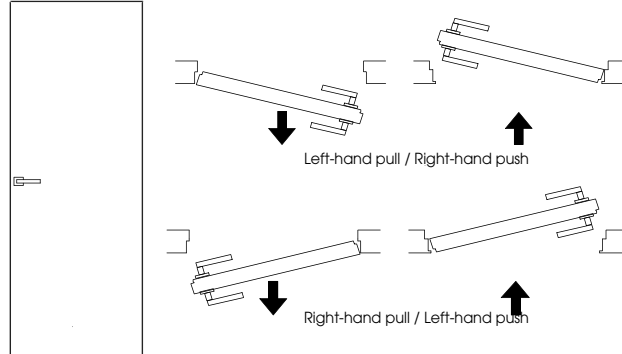
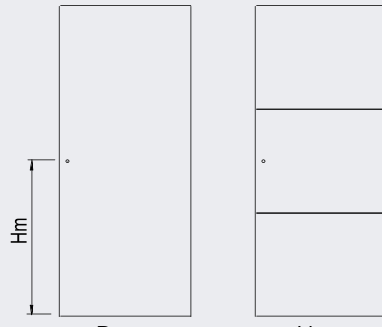
<p>Trésor doors</p>	<p><b>Essential Swing single door (door only)</b>                  Hollow-core door with rebate on 3 sides, with frame in jointed fir or solid tulipwood or ash and paper honeycomb core with hexagonal cells, covered with panels of wood fibreboard or medium density fibreboard (MDF) with a natural ash veneer surface for the lacquered ash finish.                  Door thickness 55 mm with horizontal grain on panels and vertical grain on edges for the lacquered ash finish.</p>
<p>Versions</p>	 <p>Version:</p> <ul style="list-style-type: none"> <li>• Right-hand pull / Left-hand push</li> <li>• Left-hand pull / Right-hand push</li> </ul> <p>NB: The push version permits maximum door opening to 90°/100°, with a consequent reduction of the clear opening width.</p>
<p>Models</p>	 <ul style="list-style-type: none"> <li>• Pure full panel, thickness 55 mm</li> <li>• Linea full panel, thickness 55 mm with 2 small machined grooves, lacquered like the door</li> </ul> <p>Handle height:</p> <ul style="list-style-type: none"> <li>• Hm=1035</li> </ul>
<p>Doorpost type</p>	<p>This product requires no doorpost</p>
<p>Standard dimensions</p>	<ul style="list-style-type: none"> <li>• Width (in mm) from 600 to 1000</li> <li>• Height (in mm) from 1800 to 2700</li> </ul>
<p>Finishes</p>	<ul style="list-style-type: none"> <li>• Open-pore ash with matt lacquer</li> <li>• Matt lacquer</li> <li>• Gloss lacquer</li> <li>• Primer</li> </ul> <p>Standard colours RAL1013/1015/9001/9002/9003/9010/9016/9018                  On request the entire range of RAL colours is available.</p>
<p>Wall thickness</p>	<ul style="list-style-type: none"> <li>• Can be installed on Essential swing frames for any wall thickness indicated in the price list</li> </ul>
<p>Finishes on accessories (included in supply)</p>	<ul style="list-style-type: none"> <li>• Mortised for hinges, 3 up to height 2399, 4 over 2400</li> <li>• Mortised for lock*</li> <li>• Machined grooves for seal</li> <li>• Straightener rod inside door for heights over 2400</li> </ul> <p>* Pre-mortised keyholes by request only</p>
<p>Closure type</p>	<p>Pre-mortised (hole) for:</p> <ul style="list-style-type: none"> <li>• Magnetic lock (key/spindle/cylinder)</li> <li>• Roller catch</li> <li>• Roller catch + recessed handles</li> <li>• Roller catch with inset handle and recess *</li> <li>• Lock + keyhole for electric strike plate</li> </ul> <p>* Available for matt lacquer finishes or with primer only.</p>

### Essential Swing single door without crosspiece (door only)

Hollow-core door with rebate on 2 sides, with frame in jointed fir or solid tulipwood or ash and paper honeycomb core with hexagonal cells, covered with panels of wood fibreboard or medium density fibreboard (MDF) with a natural ash veneer surface for the lacquered ash finish.  
Door thickness 55 mm with horizontal grain on panels and vertical grain on edges for the lacquered ash finish.

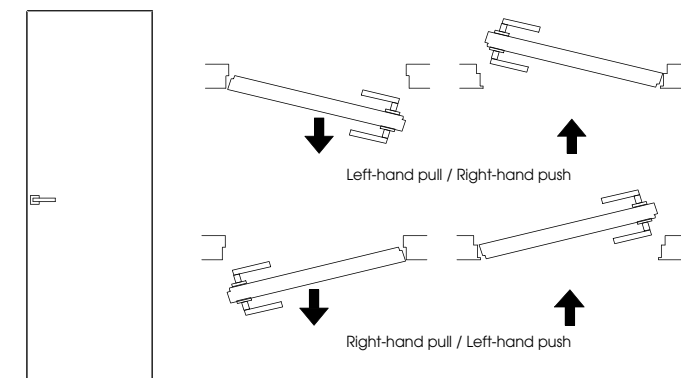

Version:

- Right-hand pull / Left-hand push
- Left-hand pull / Right-hand push

NB: The push version permits maximum door opening to 90°/100°, with a consequent reduction of the clear opening width.

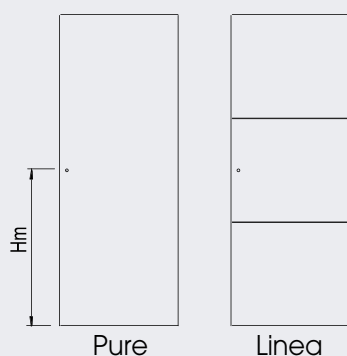

- Pure full panel, thickness 55 mm
- Linea full panel, thickness 55 mm with 2 small machined grooves, lacquered like the door

Handle height:

- Hm=1030

This product requires no doorpost

- Width (in mm) from 600 to 1000
- Height (in mm) from 1800 to 2700

- Open-pore ash with matt lacquer
- Matt lacquer
- Gloss lacquer
- Primer

Standard colours RAL1013/1015/9001/9002/9003/9010/9016/9018  
On request the entire range of RAL colours is available.

- Can be installed on Essential swing frames for any wall thickness indicated in the price list

- Mortised for hinges, 3 up to height 2399, 4 over 2400
- Mortised for lock\*
- Machined grooves for seal
- Straightener rod inside door for heights over 2400
- \* Pre-mortised keyholes by request only

Pre-mortised (hole) for:

- Magnetic lock (key/spindle/cylinder)
- Roller catch
- Roller catch + recessed handles
- Roller catch with inset handle and recess \*
- Lock + keyhole for electric strike plate
- Machined for incorporated door closer
- \* Available for matt lacquer finishes or with primer only.

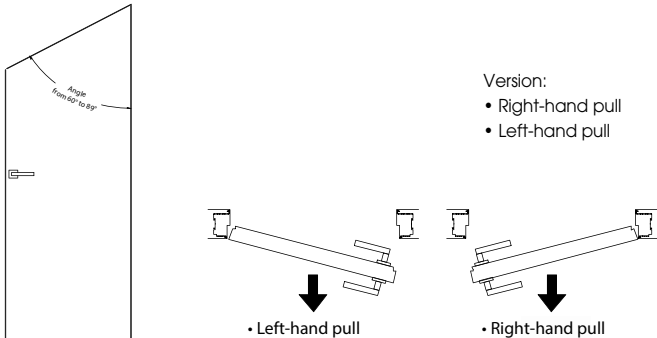
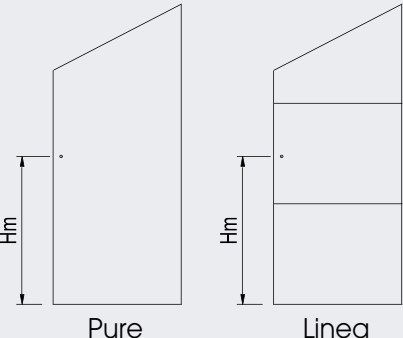
<p>Trésor doors</p>	<p><b>Essential Swing single trapezoidal door (door only)</b></p> <p>Hollow-core door with rebate on 3 sides, with frame in jointed fir or solid tulipwood or ash and paper honeycomb core with hexagonal cells, covered with panels of wood fibreboard or medium density fibreboard (MDF) with a natural ash veneer surface for the lacquered ash finish. Door thickness 55 mm with horizontal grain on panels and vertical grain on edges for the ash finish.</p>
<p>Versions</p>	 <p>Version:</p> <ul style="list-style-type: none"> <li>• Right-hand pull</li> <li>• Left-hand pull</li> </ul>
<p>Models</p>	 <p>Pure                      Linea</p> <ul style="list-style-type: none"> <li>• Pure full panel, thickness 55 mm</li> <li>• Linea full panel, thickness 55 mm with 2 small machined grooves, lacquered like the door</li> <li>• Sold together with the frame</li> </ul> <p>Handle height:</p> <ul style="list-style-type: none"> <li>• Hm=1035</li> </ul>
<p>Doorpost type</p>	<p>This product requires no doorpost</p>
<p>Standard dimensions</p>	<ul style="list-style-type: none"> <li>• Width (in mm) from 600 to 1000</li> <li>• Height (in mm) from 1800 to 3000</li> </ul>
<p>Finishes</p>	<ul style="list-style-type: none"> <li>• Open-pore ash with matt lacquer</li> <li>• Matt lacquer</li> <li>• Gloss lacquer</li> <li>• Fondo</li> </ul> <p>Standard colours RAL 1013/1015/9001/9002/9003/9010/9016/9018 On request the entire range of RAL colours is available.</p>
<p>Wall thickness</p>	<ul style="list-style-type: none"> <li>• Can be installed on Essential swing frames for any wall thickness indicated in the price list</li> </ul>
<p>Finishes on accessories (included in supply)</p>	<ul style="list-style-type: none"> <li>• Mortised for hinges, 3 up to height 2399, 4 over 2400</li> <li>• Mortised for lock*</li> <li>• Machined grooves for seal</li> </ul> <p>* Pre-mortised keyholes by request only</p>
<p>Closure type</p>	<p>Pre-mortised (hole) for:</p> <ul style="list-style-type: none"> <li>• Magnetic lock (key/spindle/cylinder)</li> <li>• Roller catch</li> <li>• Roller catch + recessed handles</li> <li>• Roller catch with inset handle and recess *</li> <li>• Lock + keyhole for electric strike plate</li> </ul> <p>* Available for matt lacquer finishes or with primer only.</p>

## Essential Swing double door (doors only)

Hollow-core door with rebate on 3 sides, with frame in jointed fir or solid tulipwood or ash and paper honeycomb core with hexagonal cells, covered with panels of wood fibreboard or medium density fibreboard (MDF) with a natural ash veneer surface for the lacquered ash finish.

Door thickness 55 mm with horizontal grain on panels and vertical grain on edges for the lacquered ash finish.

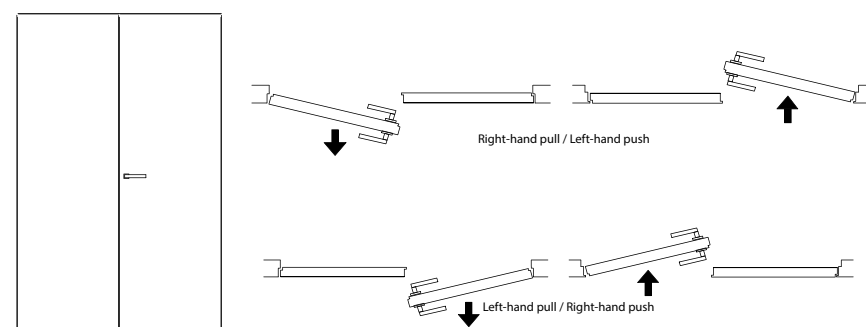

Version:

- Right-hand pull / Left-hand push
- Left-hand pull / Right-hand push

NB: The push version permits maximum door opening to 90°/100°, with a consequent reduction of the clear opening width.

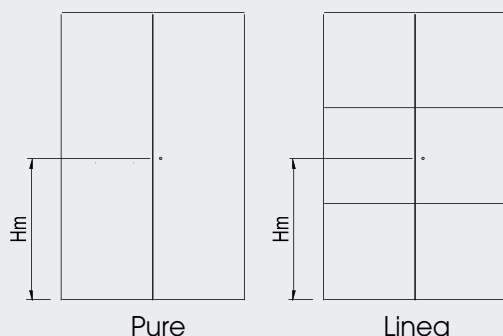

- Pure full panel, thickness 55 mm
- Linea full panel, thickness 55 mm with 2 small machined grooves, lacquered like the door

Handle height:

- Hm=1035

This product requires no doorpost

- Width (in mm) from 1200 to 1800
- Height (in mm) from 1800 to 2700

- Open-pore ash with matt lacquer
- Matt lacquer
- Gloss lacquer
- Primer

Standard colours RAL 1013/1015/9001/9002/9003/9010/9016/9018

On request the entire range of RAL colours is available.

- Can be installed on Essential swing frames for any wall thickness indicated in the price list

- Mortised for hinges, 3 up to height 2399, 4 over 2400
- Mortised for lock\*
- Machined grooves for seal
- Grooved for bolts on second door
- Straightener rod inside door for heights over 2400
- \* Pre-mortised keyholes by request only

Pre-mortised (hole) for:

- Magnetic lock (key/spindle/cylinder)
- Roller catch
- Roller catch + recessed handles
- Roller catch with inset handle and recess \*
- Lock + keyhole for electric strike plate

\* Available for matt lacquer finishes or with primer only.

# Porta Trésor Battente per Essential modello Pure e Linea

## Trésor Swing door Pure and Linea model for Essential

Singola  
Single

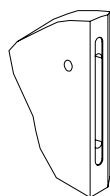
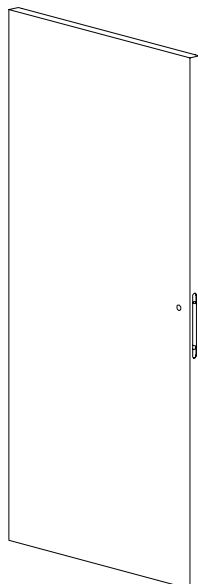

Anta con foro  
Serratura Magnetica  
Door with magnetic  
lock hole

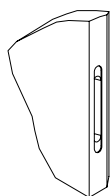

Anta con foro  
Serratura Rullo  
Door with  
roll lock hole

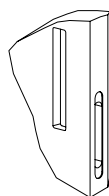

Anta con foro  
Serratura Rullo e  
foro per Vaschetta  
Door with lock hole  
and hole for roll pan

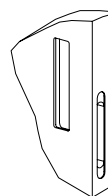

Anta con foro  
Serratura Rullo e  
Maniglia ricavata con incasso\*  
Door with lock hole and roller  
with integrated handle\*

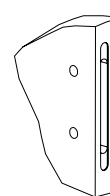

Anta con foro  
Serratura e foro chiave  
Door with lock and key hole

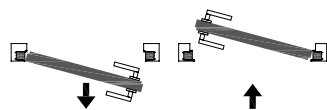

Tirare Sx / Spingere Dx  
Pull Left / Push Right

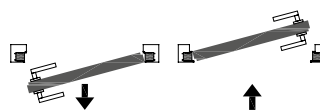

Tirare Dx / Spingere Sx  
Pull Right / Push Left

Luce di passaggio / Clear opening size	
L	H
600 ÷ 1000	1800 ÷ 2700

\* Disponibile solo per ante laccate opache o con solo fondo / Available only for mat panel or panel with primer.

Prima di ordinare la porta è necessario verificare che la misura del telaio ordinato corrisponda all'effettiva misura della luce rilevata in cantiere dopo la posa.

Before ordering the panels, it is necessary to check that the measure of the frame corresponds to the effective clear opening size after onsite installation.

# Porta Trésor Battente per Essential modello Pure e Linea

## *Trésor Swing door Pure and Linea model for Essential*

Doppia  
*Double*

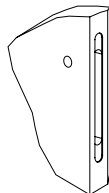
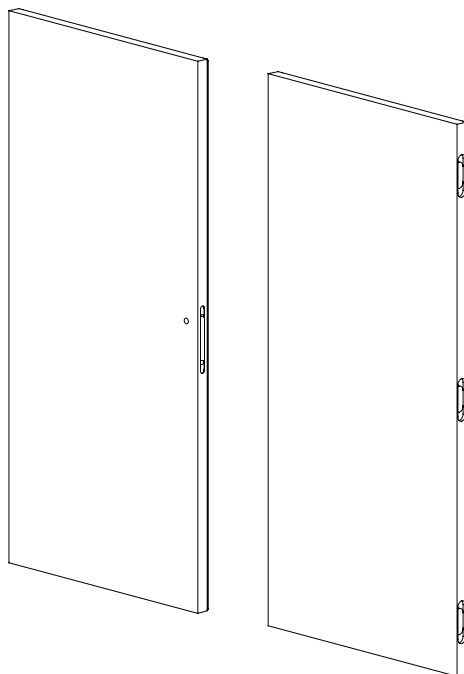

Anta mobile con foro Serratura Magnetica  
*Mobile door with hole for magnetic lock*

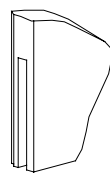

Anta fissa con fresata per Catenacci  
*Fixed door with hole for bolts*

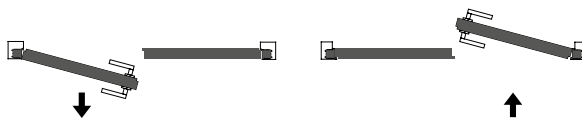

Tirare Sx / Spingere Dx  
*Pull Left / Push Right*

Luce di passaggio / <i>Clear opening size</i>	
L	H
1200 ÷ 1800	1800 ÷ 2700

Prima di ordinare la porta è necessario verificare che la misura del telaio ordinato corrisponda all'effettiva misura della luce rilevata in cantiere dopo la posa.

*Before ordering the panels, it is necessary to check that the measure of the frame corresponds to the effective clear opening size after onsite installation.*

# Porta Trésor Battente Senza Traverso per Essential modello Pure e Linea

*Trésor Swing door without upper crosspiece Pure and Linea  
model for Essential*

Singola  
*Single*

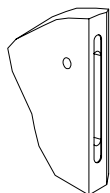
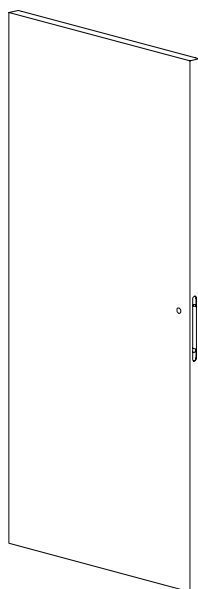

Anta con foro  
Serratura Magnetica  
*Door with magnetic  
lock hole*

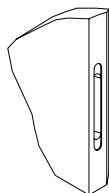

Anta con foro  
Serratura Rullo  
*Door with  
roll lock hole*

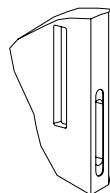

Anta con foro  
Serratura Rullo e  
foro per Vaschetta  
*Door with lock hole and hole for roll pan*

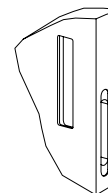

Anta con foro  
Serratura Rullo e  
Maniglia ricavata con incasso\*  
*Door with lock hole and roller  
with integrated handle\**



Tirare Sx / Spingere Dx  
*Pull Left / Push Right*

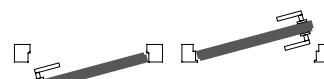

Tirare Dx / Spingere Sx  
*Pull Right / Push Left*

Luce di passaggio / <i>Clear opening size</i>	
L	H
600 ÷ 1000	1800 ÷ 3000

\* Disponibile solo per ante laccate opache o con solo fondo / *Available only for mat panel or panel with primer.*

Prima di ordinare la porta è necessario verificare che la misura del telaio ordinato corrisponda all'effettiva misura della luce rilevata in cantiere dopo la posa.

*Before ordering the panels, it is necessary to check that the measure of the frame corresponds to the effective clear opening size after onsite installation.*

# Porta Trésor Trapezoidale per Essential

modello Pure e Linea

*Trésor Swing door Trapezoidal shape Pure and Linea*

*model for Essential*

Singola  
*Single*

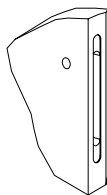
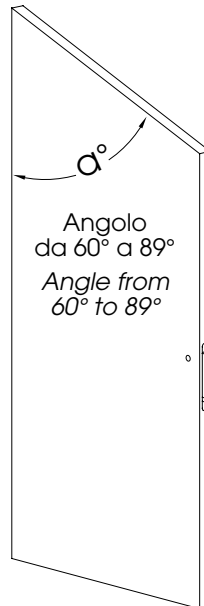

Anta con foro Serratura Magnetica  
Door with magnetic lock hole

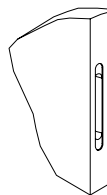

Anta con foro Serratura Rullo  
Door with roll lock hole

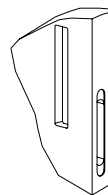

Anta con foro Serratura Rullo e foro per Vaschetta  
Door with lock hole and hole for roll pan

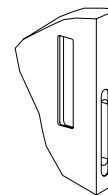

Anta con foro Serratura Rullo e Maniglia ricavata con incasso\*  
Door with lock hole and roller with integrated handle\*

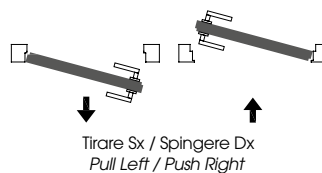

Luce di passaggio / Clear opening size	
L	H
600 ÷ 1000	1800 ÷ 2700

\* Disponibile solo per ante laccate opache o con solo fondo / Available only for mat panel or panel with primer.

Prima di ordinare la porta è necessario verificare che la misura del telaio ordinato corrisponda all'effettiva misura della luce rilevata in cantiere dopo la posa.

Before ordering the panels, it is necessary to check that the measure of the frame corresponds to the effective clear opening size after onsite installation.

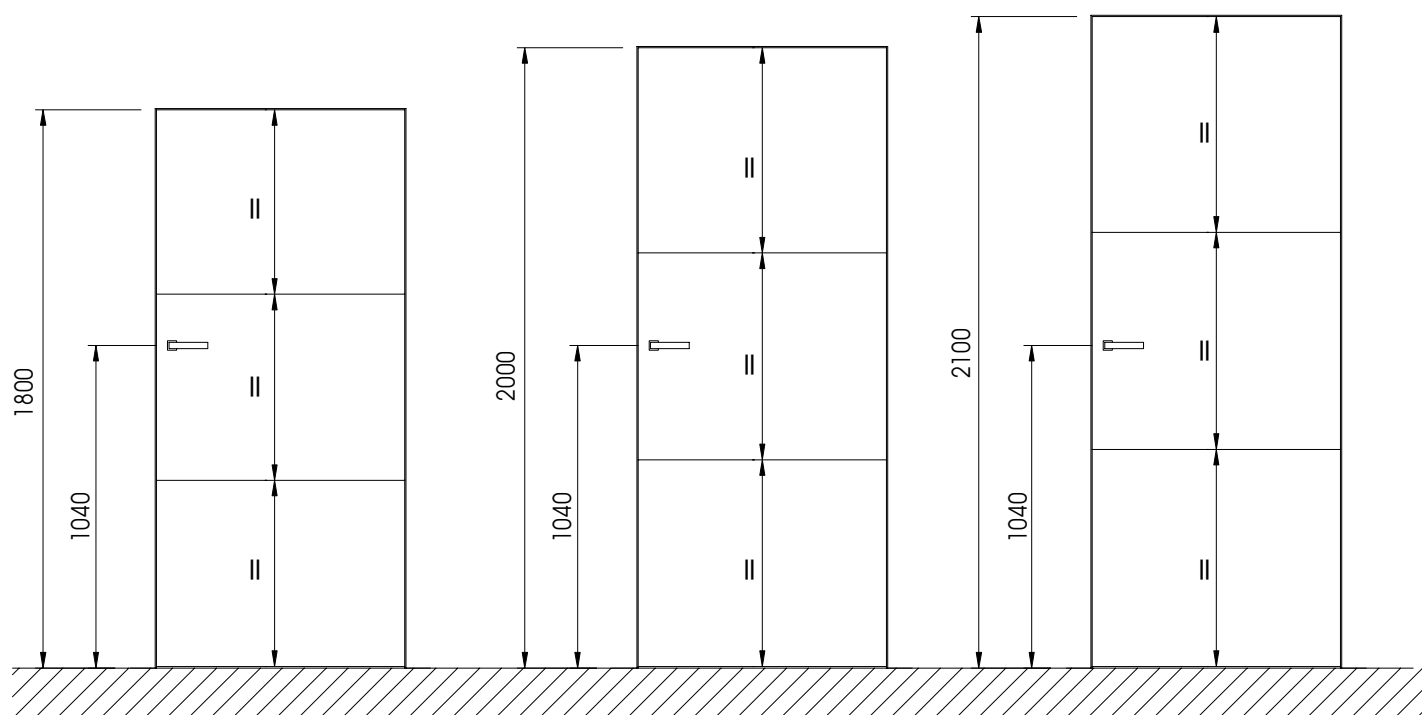

■ *Position of machined recesses on Trésor doors for Linea model*

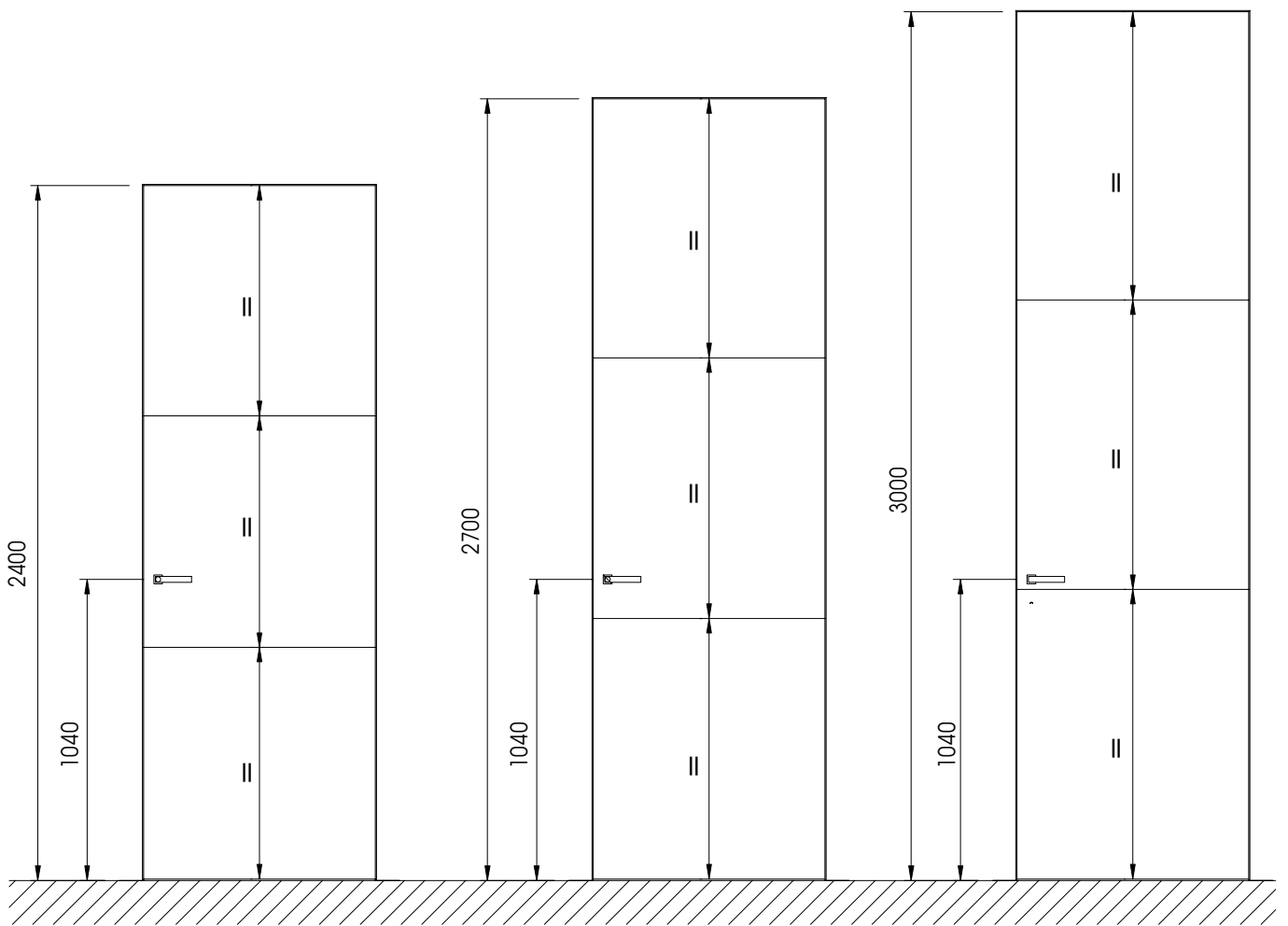

# Lavorazione serratura/maniglia ■ modello Pure e Linea per Essential Battente

## Singola Single

Lavorazione per serratura Magnetica (Quadro - Cilindro Europeo - Chiave)  
Door manufacturing for magnetic lock (square - european cylinder - key)

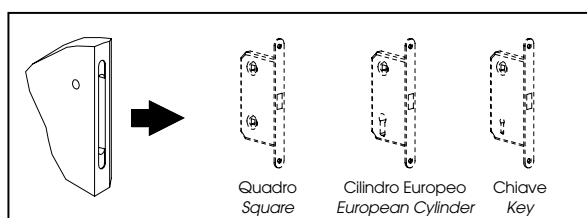

Lavorazione per serratura Rullo + Maniglia ricavata con incasso\*  
Door manufacturing for lock + integrated handle\*

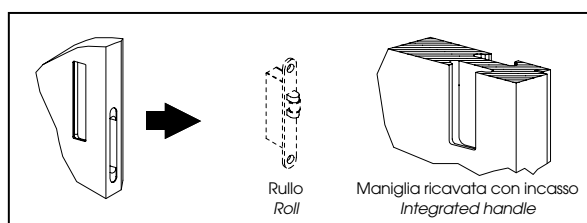

\* Ecluso frassinato e laccato lucido

Lavorazione per serratura Rullo  
Door manufacturing for roll lock

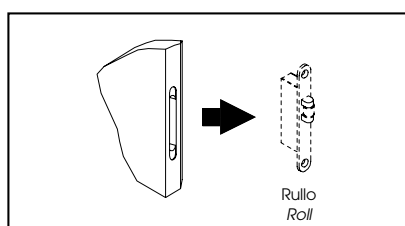

Lavorazione per serratura Rullo + foro per Vaschetta  
Door manufacturing for lock + hole for pocket handles

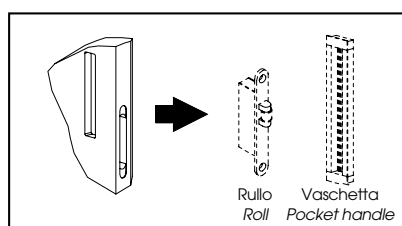

Lavorazione serratura + foro Chiave per riscontro elettrico  
Door manufacturing for lock + hole for electric strike

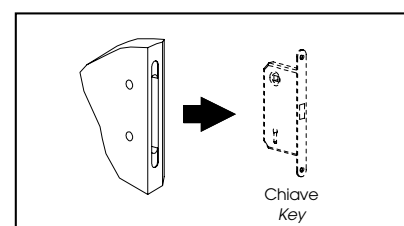

# Machining for lock/handles

## Pure and Linea models for Essential Swing doors

### Doppia Double

Lavorazione per serratura Magnetica (Quadro - Cilindro Europeo - Chiave)  
Door manufacturing for magnetic lock (square - european cylinder - key)

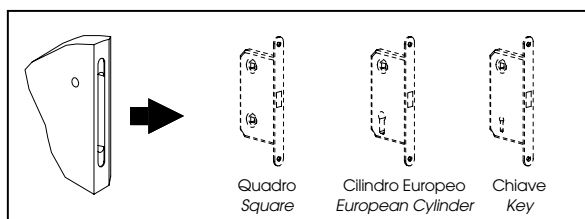

Lavorazione per serratura Rullo + Maniglia ricavata con incasso\*  
Door manufacturing for lock + integrated handle\*

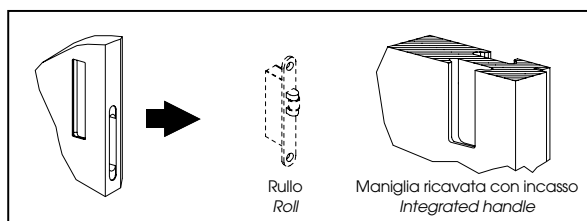

\* Ecluso frassinato e laccato lucido

Lavorazione per serratura Rullo  
Door manufacturing for roll lock

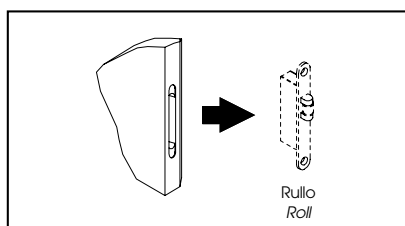

Lavorazione per serratura Rullo + foro per Vaschetta  
Door manufacturing for lock + hole for pocket handles

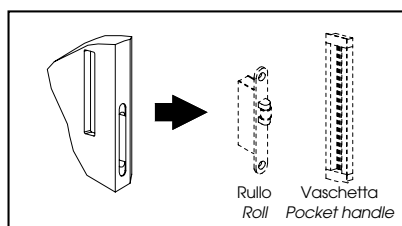

Lavorazione serratura + foro Chiave per riscontro elettrico  
Door manufacturing for lock + hole for electric strike

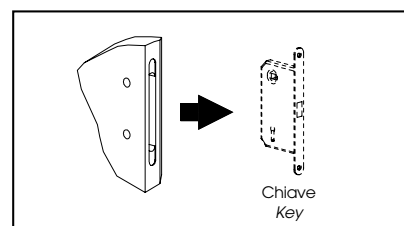

## Maniglie per Anta Battente

### Handles for swing door

Maniglia + borchia foro chiave  
Handle + escutcheon standard keyway

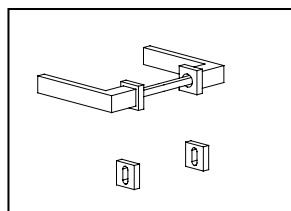

Maniglia + borchia foro cilindro europeo  
Handle + escutcheon cylinder profile

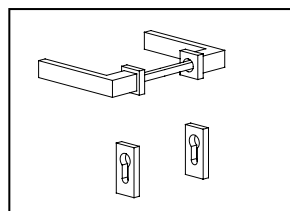

Maniglia + borchia con nottolino  
Handle + wc release and inside turns

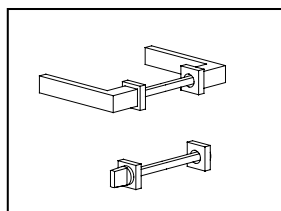

Coppia vaschetta  
Pocket handles

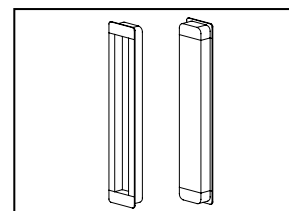



Soluzioni vetro  
*Glass solutions*

# Porta Scorrevole in vetro per Essential

## Sliding glass door for Essential

Singola  
Single

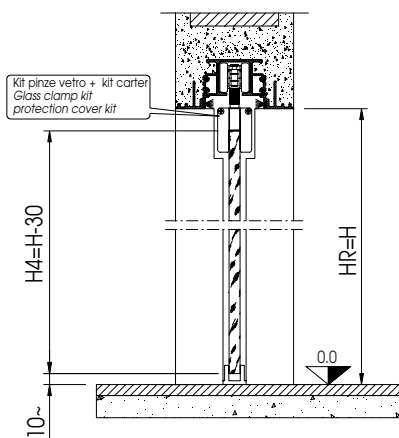

Eseguire sempre il rilievo misure prima di ordinare la porta  
Always take measurements before ordering the door

Esempio composizione prodotto:  
Example of product composition:

- n°1 Kit pinze clamp kit
- n°1 Kit carter Protection cover kit
- n°1 Kit compensatori anta singola Compensation profile kit for single doors
- n°1 Anta vetro Essential singola Single glass door Essential
- n°1 Coppia maniglia Pair of handles

Optional:

- n°1 Slow glass Slow Glass kit

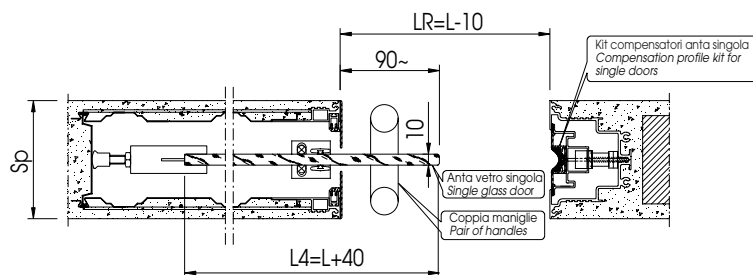

Apertura a SX - Left-hand opening

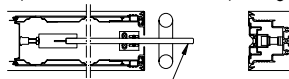

Lato acidato  
Frosted side

Apertura a DX - Right-hand opening

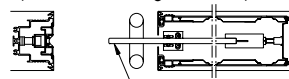

Lato acidato  
Frosted side



ALLUMINIO  
ALUMINIUM



VETRO TEMPERATO  
TEMPERED GLASS

Luca di passaggio Clear opening size L x H	Luca reale Effective opening dimensions LR x HR	Misura anta Door measurement L4 x H4	Spessore parete Finished wall Sp
600 x 1800 ÷ 2700	590 x 1800 ÷ 2700	640 x 1770 ÷ 2670	Intonaco Plastered 105 - 125 - 145
700 x 1800 ÷ 2700	690 x 1800 ÷ 2700	740 x 1770 ÷ 2670	
750 x 1800 ÷ 2700	740 x 1800 ÷ 2700	790 x 1770 ÷ 2670	
800 x 1800 ÷ 2700	790 x 1800 ÷ 2700	840 x 1770 ÷ 2670	Cartongesso Plasterboard 100* - 125 *H. max 2100
900 x 1800 ÷ 2700	890 x 1800 ÷ 2700	940 x 1770 ÷ 2670	
1000 x 1800 ÷ 2700	990 x 1800 ÷ 2700	1040 x 1770 ÷ 2670	
*1100 x 1800 ÷ 2700	1090 x 1800 ÷ 2700	1140 x 1770 ÷ 2670	
*1200 x 1800 ÷ 2700	1190 x 1800 ÷ 2700	1240 x 1770 ÷ 2670	

\* Solo per spessore parete 105 - 125 - Only for walls thickness 105 - 125 - 145

# Porta Scorrevole in vetro per Essential

## Sliding glass door for Essential

Doppia  
Double

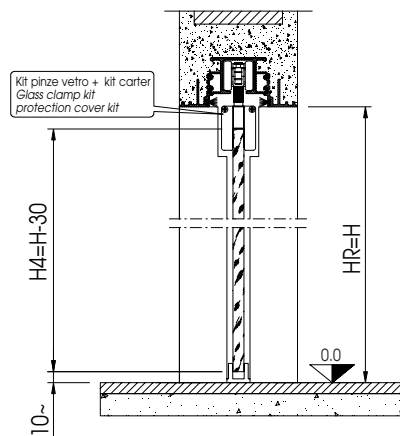

Eeguire sempre il rilievo misure prima di ordinare la porta  
Always take measurements before ordering the door

Esempio composizione prodotto:  
Example of product composition:

- n°2 Kit pinze  
clamp kits
- n°2 Kit carter  
Protection cover kits
- n°1 Kit compensatori anta doppia  
Compensation profile kit for double doors
- n°1 Anta vetro Essential doppia  
Double glass door Essential
- n°2 Coppia maniglia  
Pairs of handles

Optional:  
n°2 Slow glass  
Slow Glass kits

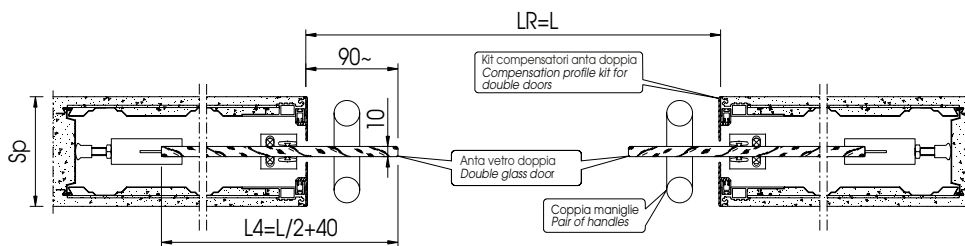

ALLUMINIO  
ALUMINIUM

VETRO TEMPERATO  
TEMPERED GLASS

Luca di passaggio Clear opening size L x H	Luca reale Effective opening dimensions LR x HR	Misura anta Door measurement L4 x H4	Spessore parete Finished wall Sp
1200 x 1800 ÷ 2700	1200 x 1800 ÷ 2700	640 x 1770 ÷ 2670	Intonaco Plastered 105 - 125 - 145
1400 x 1800 ÷ 2700	1400 x 1800 ÷ 2700	740 x 1770 ÷ 2670	
1600 x 1800 ÷ 2700	1600 x 1800 ÷ 2700	840 x 1770 ÷ 2670	
1800 x 1800 ÷ 2700	1800 x 1800 ÷ 2700	940 x 1770 ÷ 2670	Cartongesso Plasterboard 100* - 125 *H. max 2100
2000 x 1800 ÷ 2700	2000 x 1800 ÷ 2700	1040 x 1770 ÷ 2670	
*2200 x 1800 ÷ 2700	2200 x 1800 ÷ 2700	1140 x 1770 ÷ 2670	
*2400 x 1800 ÷ 2700	2400 x 1800 ÷ 2700	1240 x 1770 ÷ 2670	

\* Solo per spessore parete 105 - 125 - Only for walls thickness 105 - 125 - 145

# Porta Scorrevole in vetro per Trial

## Sliding glass door for Trial

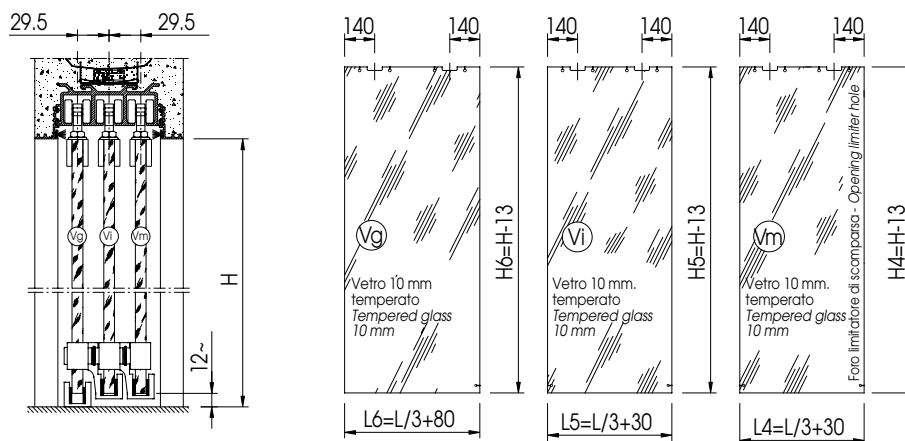

Eeguire sempre il rilievo misure prima di ordinare la porta  
Always take measurements before ordering the door

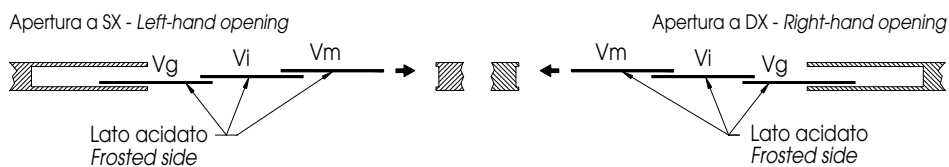
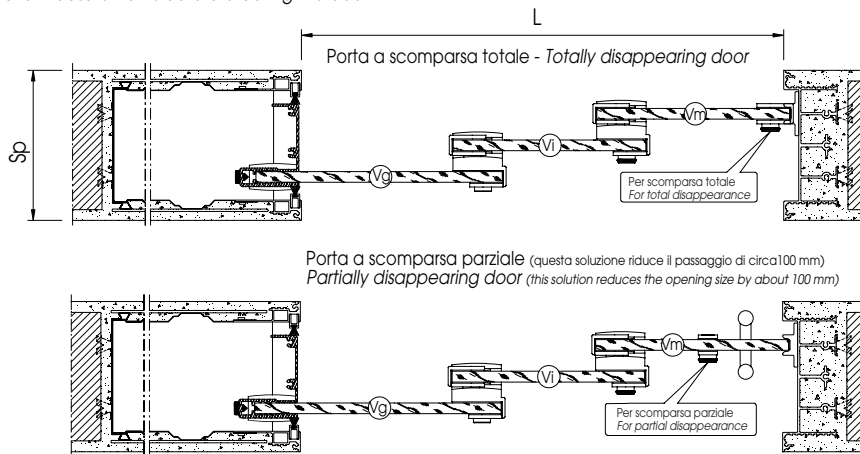

ALLUMINIO / ALUMINIUM

VETRO TEMPERATO / TEMPERED GLASS

Luce di passaggio Clear opening size L x H	Misura anta Vm Door measurement VM L4 x H4	Misura anta Vi Door measurement VI L5 x H5	Misura anta Vg Door measurement VG L6 x H6	Spessore parete Finished wall Sp
1650 x 2100	580 x 2087	580 x 2087	630 x 2087	Intonaco Plastered 140 Cartongesso Plasterboard 158
1800 x 2100	630 x 2087	630 x 2087	680 x 2087	
1950 x 2100	680 x 2087	680 x 2087	780 x 2087	
2100 x 2100	730 x 2087	730 x 2087	780 x 2087	
2250 x 2100	780 x 2087	780 x 2087	830 x 2087	
2400 x 2100	830 x 2087	830 x 2087	880 x 2087	
2550 x 2100	880 x 2087	880 x 2087	930 x 2087	
2700 x 2100	930 x 2087	930 x 2087	980 x 2087	
2850 x 2100	980 x 2087	980 x 2087	1030 x 2087	

# Porta Scorrevole in vetro per Dual

## Sliding glass door for Dual

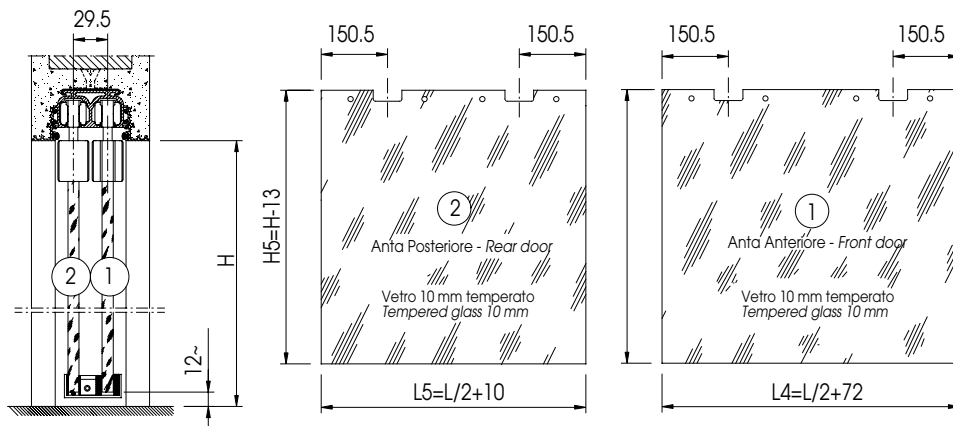

Eeguire sempre il rilievo misure prima di ordinare la porta  
Always take measurements before ordering the door

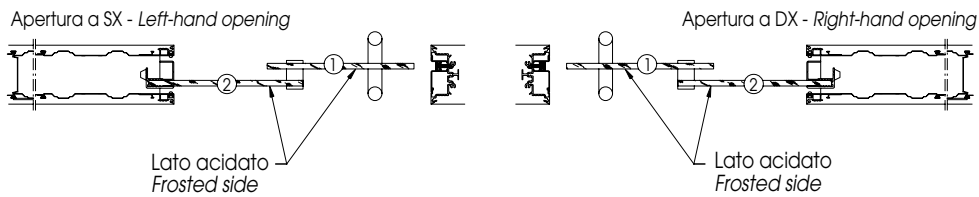
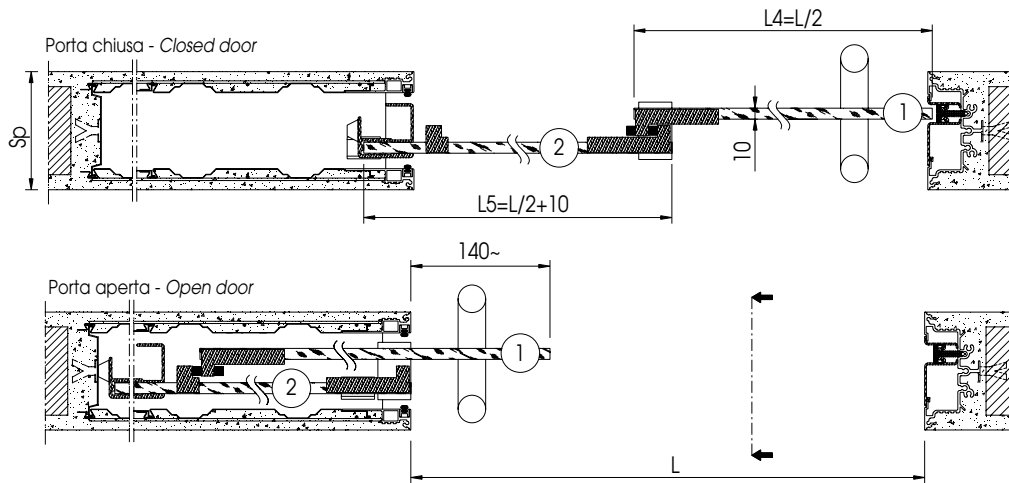

ALLUMINIO ALUMINIUM  
VETRO TEMPERATO TEMPERED GLASS

Luce di passaggio Clear opening size L x H	Misura anta 1 Door measurement 1 L4 x H4	Misura anta 2 Door measurement 2 L5 x H5	Spessore parete Finished wall Sp
1200 x 2000 ÷ 2400	672 x 1987 ÷ 2387	610 x 1987 ÷ 2387	Intonaco Plastered 105
1400 x 2000 ÷ 2400	772 x 1987 ÷ 2387	710 x 1987 ÷ 2387	
1600 x 2000 ÷ 2400	872 x 1987 ÷ 2387	810 x 1987 ÷ 2387	

# Porta Acqua Scorrevole in vetro e alluminio per Essential

## Acqua glass and aluminium Sliding door for Essential

Singola  
Single

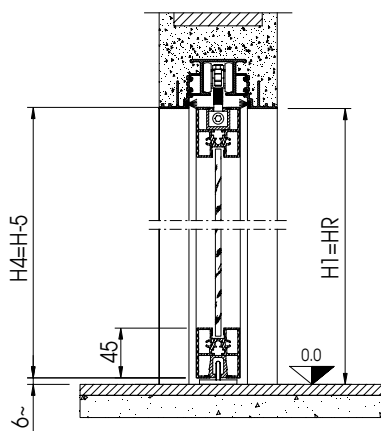

Eseguire sempre il rilievo misure prima di ordinare la porta  
Always take measurements before ordering the door

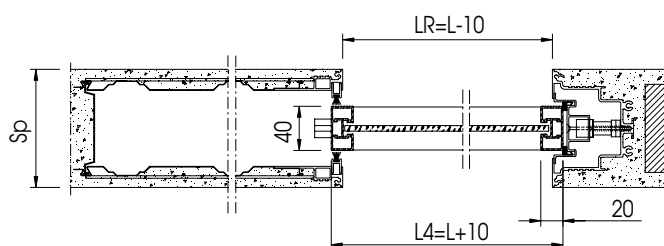

Apertura a SX - Left-hand opening

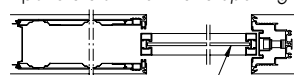

Lato satinato  
Satin-finished side

Apertura a DX - Right-hand opening

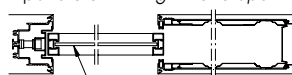

Lato satinato  
Satin-finished side



ALLUMINIO  
ALUMINIUM



VETRO TEMPERATO O STRATIFICATO  
TEMPERED OR LAMINATED GLASS

Luce di passaggio Clear opening size L x H	Luce reale Effective opening dimensions LR x HR	Misura anta Door measurement L4 x H4	Spessore parete Finished wall Sp
600 x 1900 ÷ 2700	590 x 1900 ÷ 2700	610 x 1895 ÷ 2695	Intonaco Plastered 105 - 125 - 145
700 x 1900 ÷ 2700	690 x 1900 ÷ 2700	710 x 1895 ÷ 2695	
750 x 1900 ÷ 2700	740 x 1900 ÷ 2700	760 x 1895 ÷ 2695	
800 x 1900 ÷ 2700	790 x 1900 ÷ 2700	810 x 1895 ÷ 2695	Cartongesso Plasterboard 100* - 125 *H. max 2100
900 x 1900 ÷ 2700	890 x 1900 ÷ 2700	910 x 1895 ÷ 2695	
1000 x 1900 ÷ 2700	990 x 1900 ÷ 2700	1010 x 1895 ÷ 2695	
*1100 x 1900 ÷ 2700	1090 x 1900 ÷ 2700	1110 x 1895 ÷ 2695	
*1200 x 1900 ÷ 2700	1190 x 1900 ÷ 2700	1210 x 1895 ÷ 2695	

\* Solo per spessore parete 105 - 125 - Only for walls thickness 105 - 125

# Porta Acqua Scorrevole in vetro e alluminio per Essential Acqua glass and aluminium Sliding door for Essential

Doppia  
Double

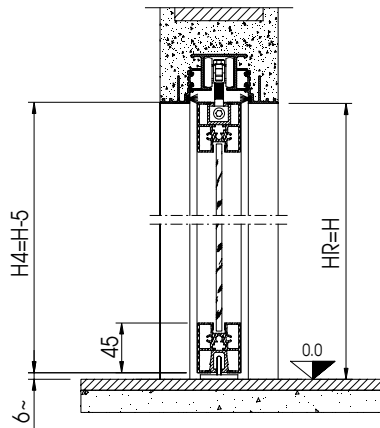

Eeguire sempre il rilievo misure prima di ordinare la porta  
Always take measurements before ordering the door

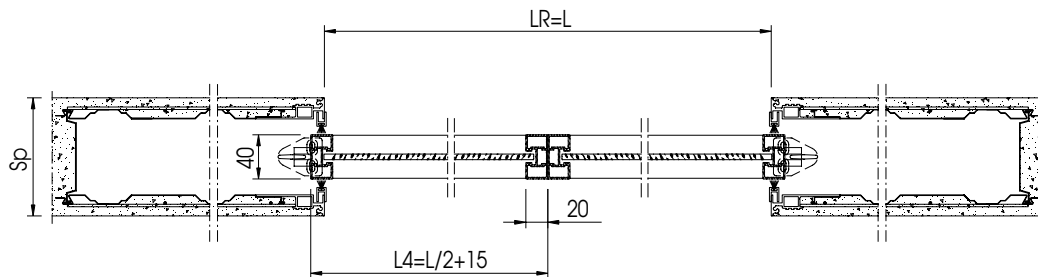

 ALLUMINIO  
ALUMINIUM

 VETRO TEMPERATO O STRATIFICATO  
TEMPERED OR LAMINATED GLASS

Luce di passaggio Clear opening size L x H	Luce reale Effective opening dimensions LR x HR	Misura anta Door measurement L4 x H4	Spessore parete Finished wall Sp
1200 x 1900 ÷ 2700	1200 x 1900 ÷ 2700	615 x 1895 ÷ 2695	Intonaco Plastered 105 - 125 - 145
1400 x 1900 ÷ 2700	1400 x 1900 ÷ 2700	715 x 1895 ÷ 2695	
1600 x 1900 ÷ 2700	1600 x 1900 ÷ 2700	815 x 1895 ÷ 2695	
1800 x 1900 ÷ 2700	1800 x 1900 ÷ 2700	915 x 1895 ÷ 2695	Cartongesso Plasterboard 100* - 125 *H. max 2100
2000 x 1900 ÷ 2700	2000 x 1900 ÷ 2700	1015 x 1895 ÷ 2695	
*2200 x 1900 ÷ 2700	2200 x 1900 ÷ 2700	1115 x 1895 ÷ 2695	
*2400 x 1900 ÷ 2700	2400 x 1900 ÷ 2700	1215 x 1895 ÷ 2695	

\* Solo per spessore parete 105 - 125 - Only for walls thickness 105 - 125

Le fotografie, i disegni, le illustrazioni e i colori hanno valore puramente indicativo.

SCRIGNO S.p.A. Unipersonale declina ogni responsabilità per le possibili inesattezze contenute, dovute ad errori di stampa, di trascrizione o per qualsiasi altro motivo e si riserva il diritto di apportare modifiche, atte a migliorare i prodotti, senza preavviso.  
La riproduzione anche parziale è severamente vietata a norma di legge.

*Photographs, diagrams, illustrations and colours are provided solely as an approximate guide.*

*SCRIGNO SpA Unipersonale declines all and any liability for possible inaccuracies herein, due to errors of printing or transcription or to any other reason, and reserves the right to make changes to improve its products without giving prior notice.  
The reproduction of this document, even partially, is strictly prohibited by law.*





Numero Verde

**800-314413**

SCRIGNO Spa Unipersonale

Via Casale S. Ermete 975 - 47822 Santarcangelo di Romagna (RN) - ITALY

Tel. +39 0541 757711 - Fax +39 0541 757780

scrigno@scrigno.it - www.scrigno.it

**SCRIGNO**<sup>®</sup>  
SINONIMO DI ECCELLENZA



[www.scrigno.net](http://www.scrigno.net)