

nice

nice line

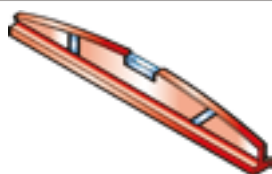

Copyright by Fontanot S.p.A., first publication February 2, 2012



2 mm 4 mm
 2,5 mm 5 mm
 3 mm 12 mm

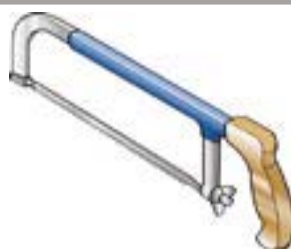

PH 2



10 mm 17 mm
 13 mm 30 mm



Ø 2,5 mm
 Ø 5 mm



Ø 8 x 300 mm
 Ø 12 x 120 mm



Ø 10 mm
 Ø 13 mm



nice line

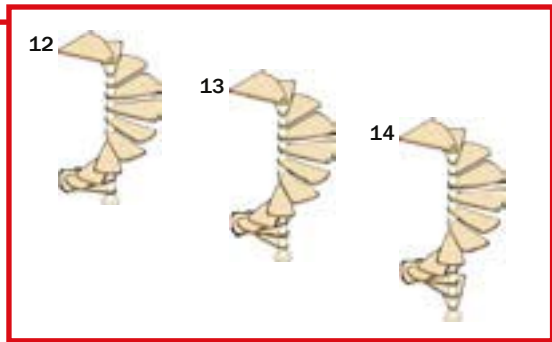
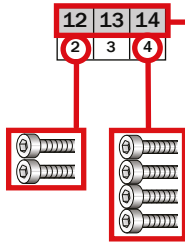

<p>A02</p> <table border="1"> <tr> <td>12</td> <td>13</td> <td>14</td> </tr> <tr> <td>1</td> <td>1</td> <td>1</td> </tr> </table>	12	13	14	1	1	1	<p>A03</p> <table border="1"> <tr> <td>12</td> <td>13</td> <td>14</td> </tr> <tr> <td>6</td> <td>6</td> <td>6</td> </tr> </table>	12	13	14	6	6	6	<p>A18</p> <table border="1"> <tr> <td>12</td> <td>13</td> <td>14</td> </tr> <tr> <td>1</td> <td>1</td> <td>1</td> </tr> </table>	12	13	14	1	1	1
12	13	14																		
1	1	1																		
12	13	14																		
6	6	6																		
12	13	14																		
1	1	1																		
<p>A20</p> <table border="1"> <tr> <td>12</td> <td>13</td> <td>14</td> </tr> <tr> <td>1</td> <td>1</td> <td>1</td> </tr> </table>	12	13	14	1	1	1	<p>B01</p> <table border="1"> <tr> <td>12</td> <td>13</td> <td>14</td> </tr> <tr> <td>1</td> <td>1</td> <td>1</td> </tr> </table>	12	13	14	1	1	1	<p>B02</p> <table border="1"> <tr> <td>12</td> <td>13</td> <td>14</td> </tr> <tr> <td>35</td> <td>37</td> <td>39</td> </tr> </table>	12	13	14	35	37	39
12	13	14																		
1	1	1																		
12	13	14																		
1	1	1																		
12	13	14																		
35	37	39																		
<p>B03</p> <table border="1"> <tr> <td>12</td> <td>13</td> <td>14</td> </tr> <tr> <td>1</td> <td>1</td> <td>1</td> </tr> </table>	12	13	14	1	1	1	<p>B04</p> <table border="1"> <tr> <td>12</td> <td>13</td> <td>14</td> </tr> <tr> <td>1</td> <td>1</td> <td>1</td> </tr> </table>	12	13	14	1	1	1	<p>B05</p> <table border="1"> <tr> <td>12</td> <td>13</td> <td>14</td> </tr> <tr> <td>1</td> <td>1</td> <td>1</td> </tr> </table>	12	13	14	1	1	1
12	13	14																		
1	1	1																		
12	13	14																		
1	1	1																		
12	13	14																		
1	1	1																		

B08



12	13	14
2	2	2

B12



12	13	14
7	7	7

B17



12	13	14
1	1	1

B23



12	13	14
2	2	2

B27



12	13	14
2	2	2

B46



12	13	14
2	2	2

B47



12	13	14
1	1	1

B54



12	13	14
20	21	22

B55



12	13	14
20	21	22

B82



12	13	14
11	12	13

B85



12	13	14
2	2	2

B86



12	13	14
2	2	2

BE3



12	13	14
19	20	21

C04



12	13	14
1	1	1

C13



12	13	14
23	25	27

C69



12	13	14
133	140	147

C76



12	13	14
28	28	28

C77



12	13	14
133	140	147

C84



12	13	14
2	2	2

C85



12	13	14
5	5	5

C87



12	13	14
4	4	4

C88



12	13	14
5	5	5

C89



12	13	14
57	61	65

C90



12	13	14
7	7	7

C91



12	13	14
5	5	5

C92



12	13	14
2	2	2

CB6



12	13	14
12	13	14

CB7



12	13	14
7	7	7

CC5



12	13	14
19	20	21

CC6



12	13	14
19	20	21

D01



12	13	14
4	4	6

D36



12	13	14
28	28	28

D37



12	13	14
28	28	28

D45



12	13	14
84	91	97

D47



12	13	14
12	13	14

E04



12	13	14
1	1	1

F01



12	13	14
8	8	8

F07



12	13	14
1	1	1

F08



12	13	14
4	4	4

F09



12	13	14
2	2	2

F12



12	13	14
2	2	2

F23



12	13	14
23	25	27

F30



12	13	14
1	1	1

G01



12	13	14
1	1	1

G02



12	13	14
2	2	2

G03



12	13	14
1	1	1

L31



12	13	14
11	12	13

X01



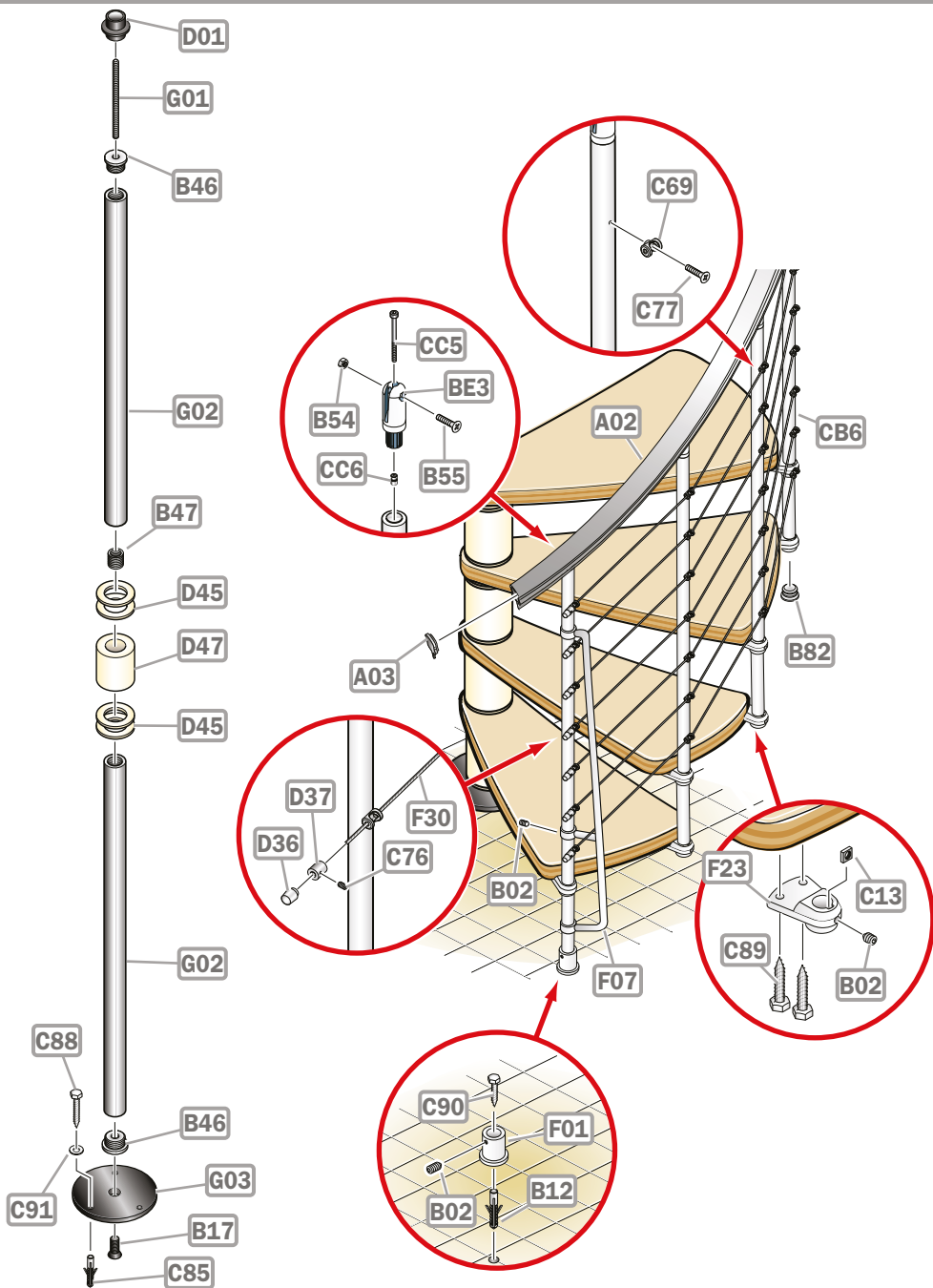

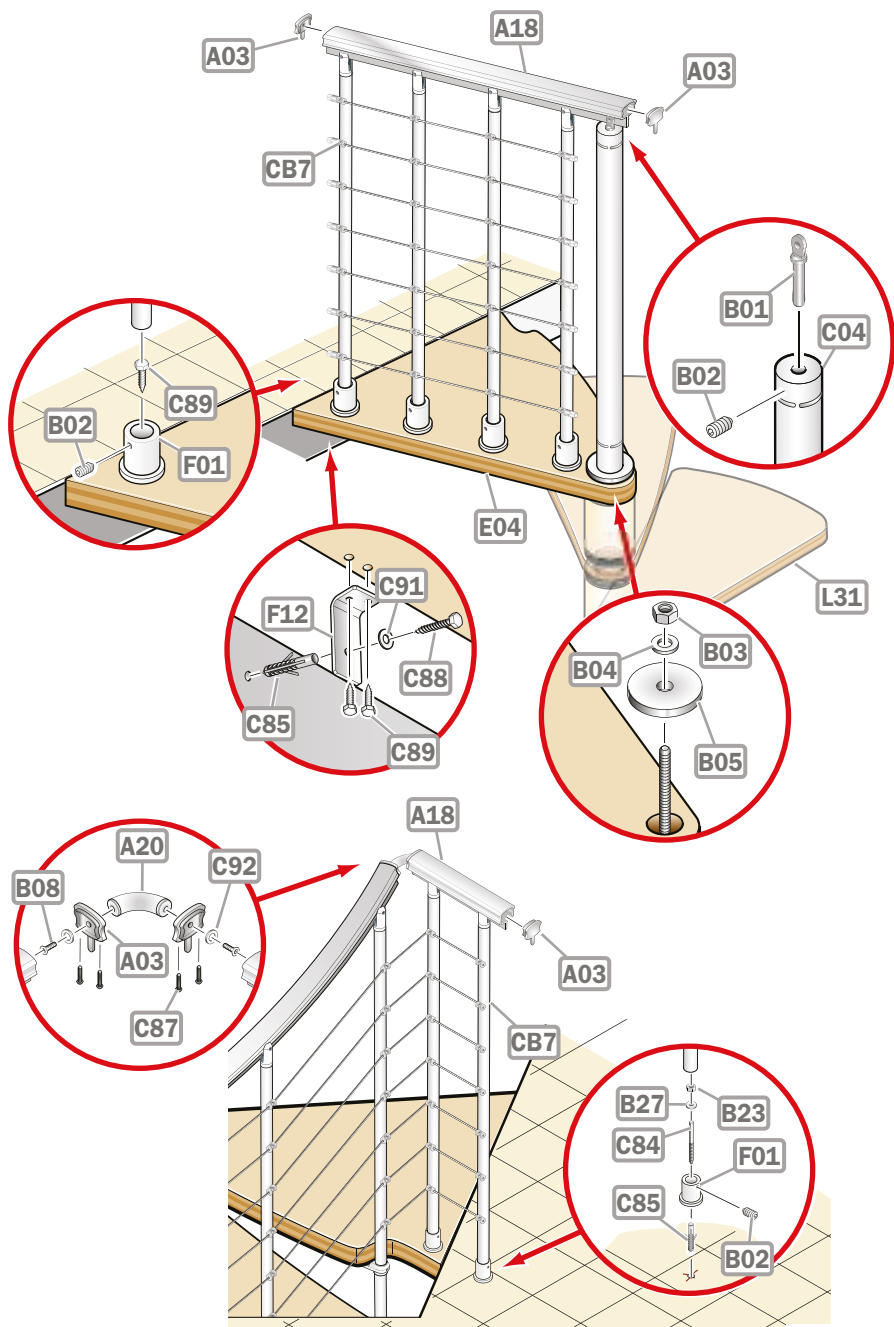

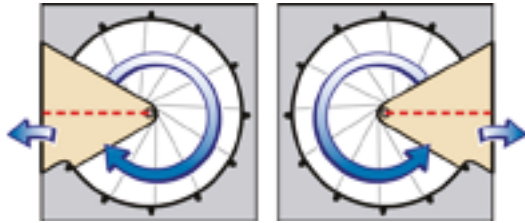

4 a

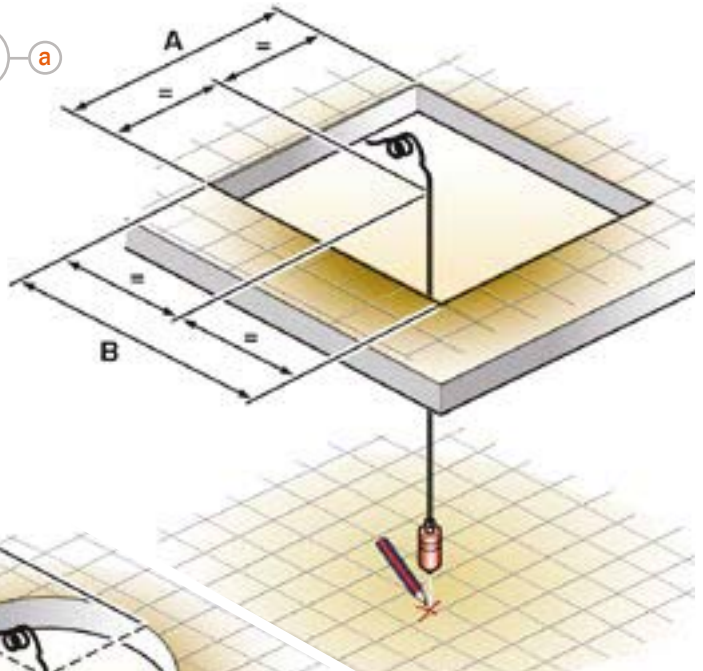

4 b

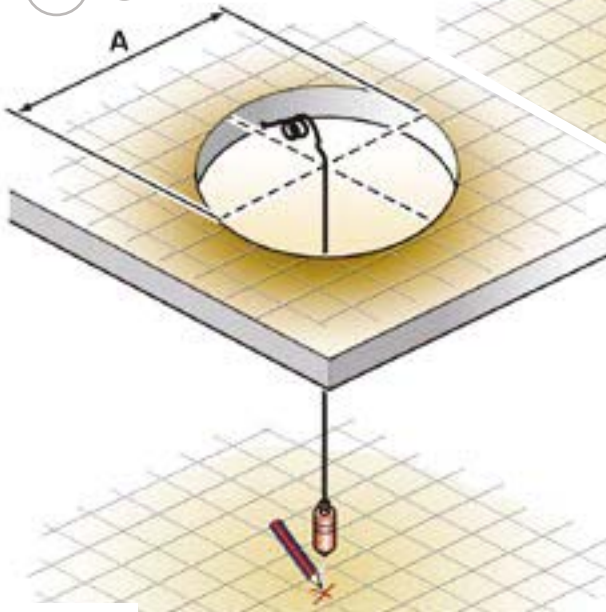

nice line

5 a

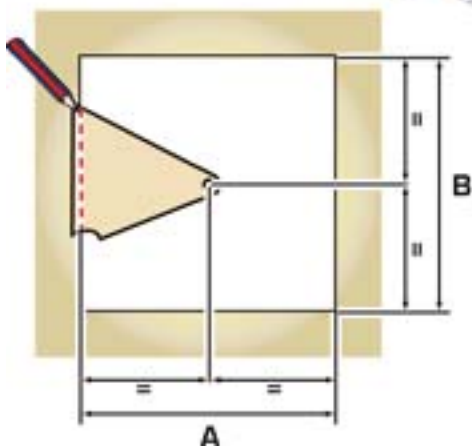
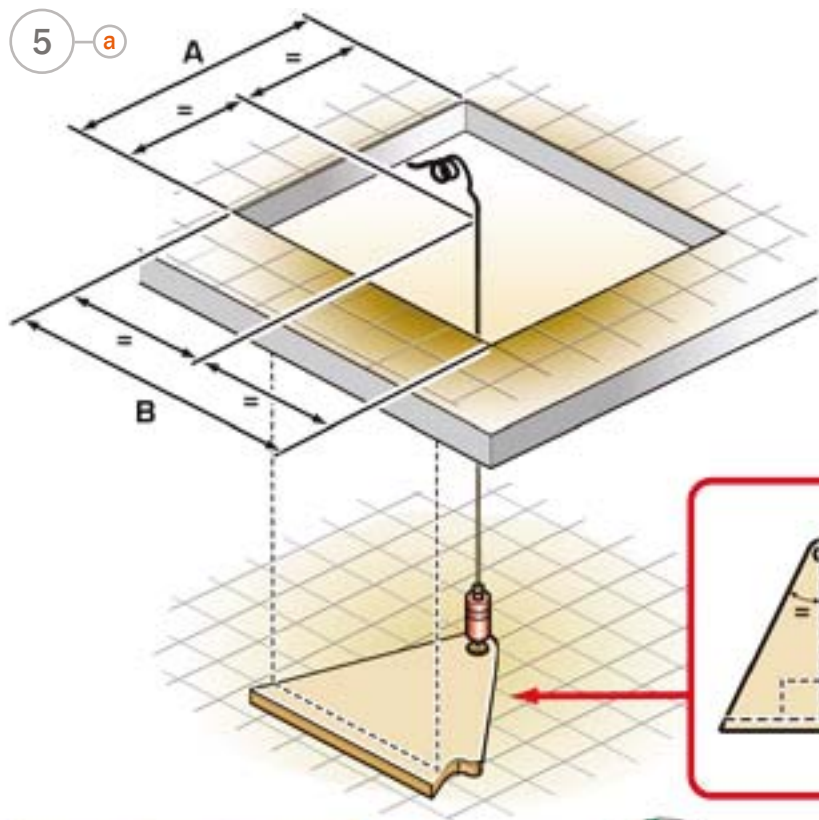

6 a

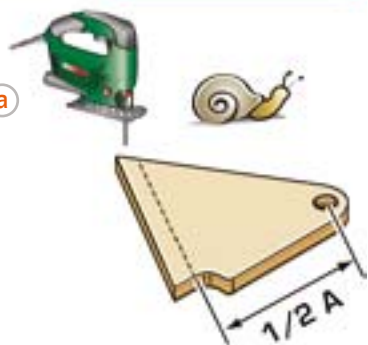

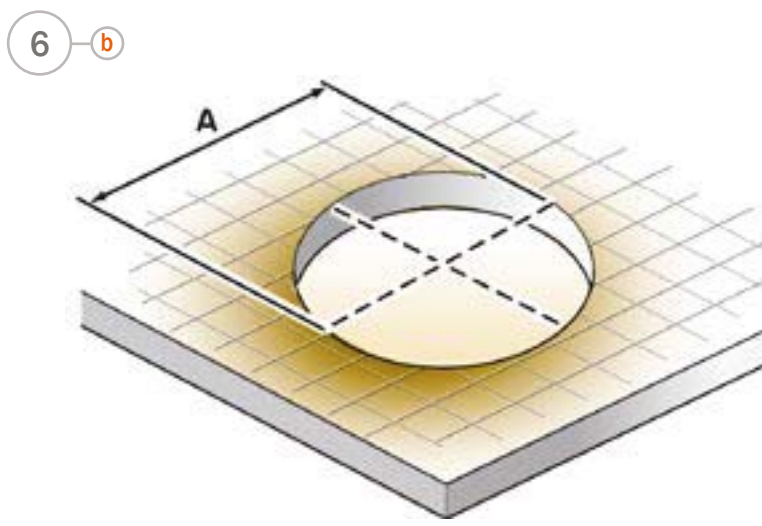
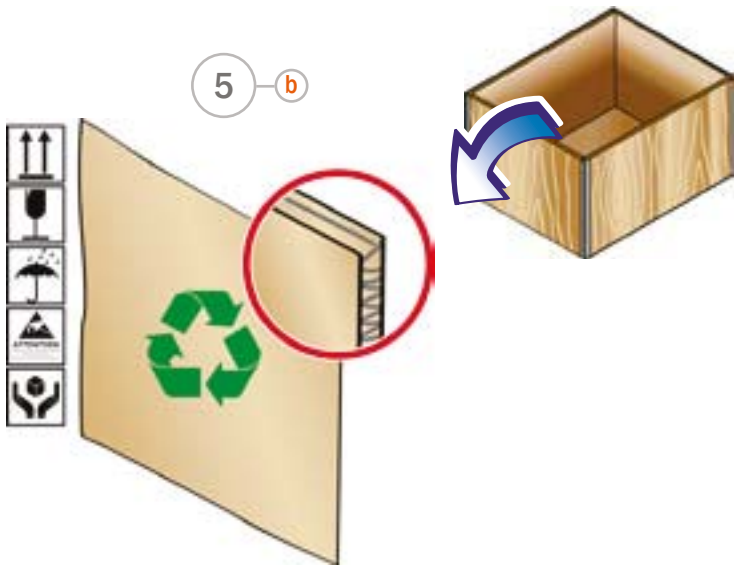

7 b

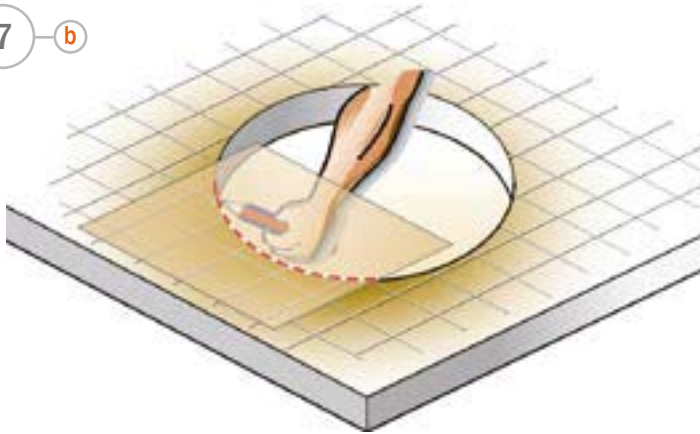

8 b

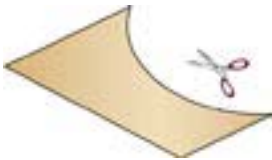

9 b

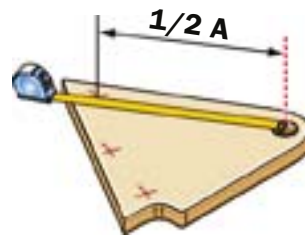

10 b



11 b



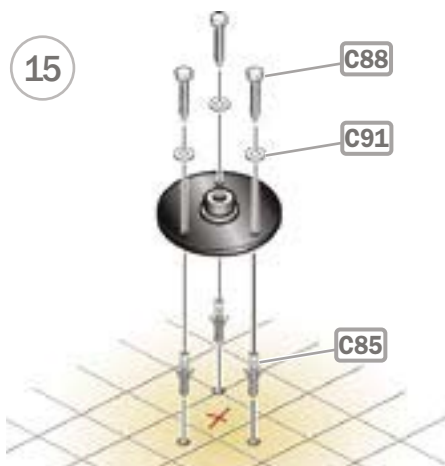
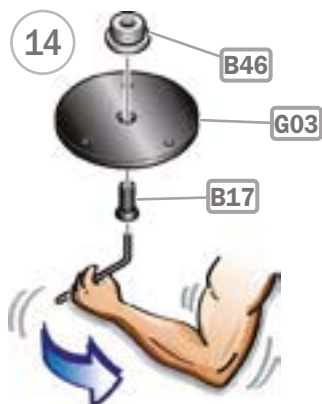
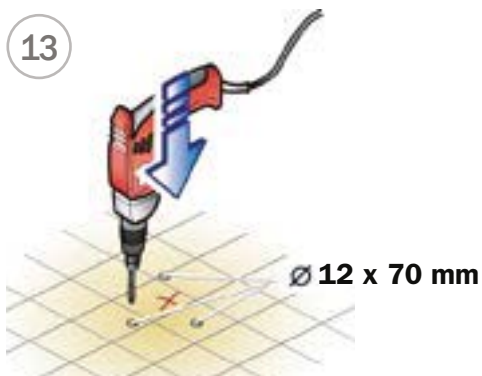

16



17

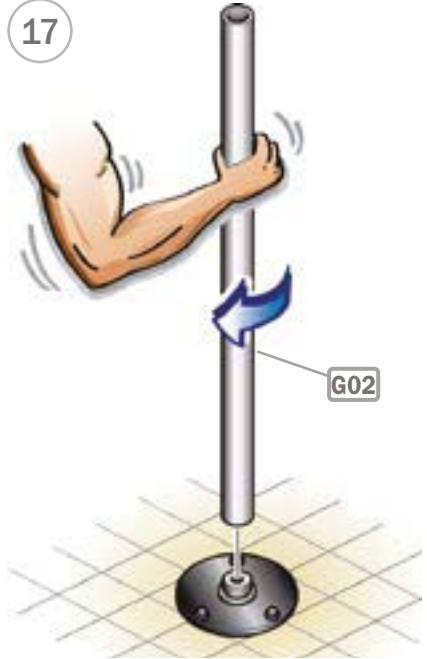

18

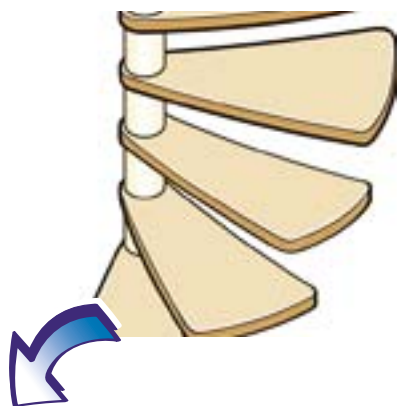

19

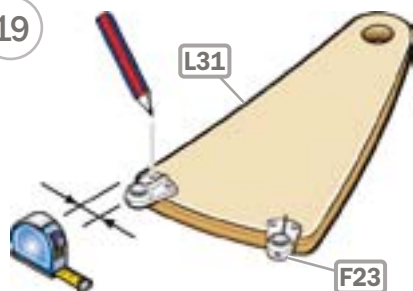

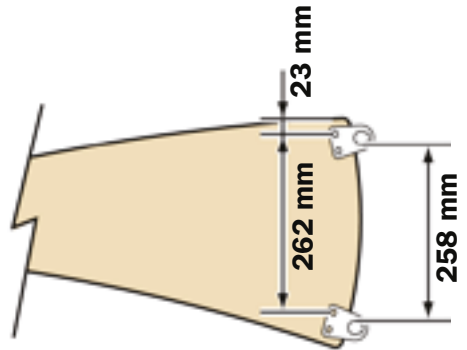
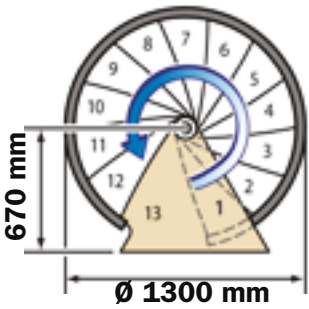
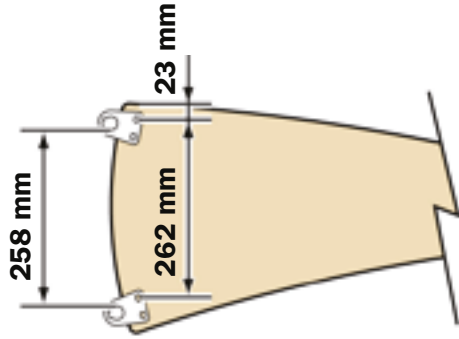
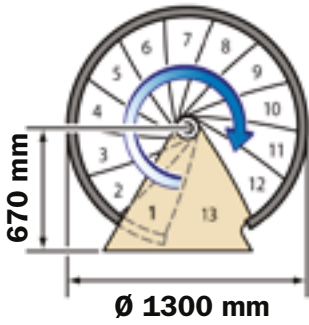

20

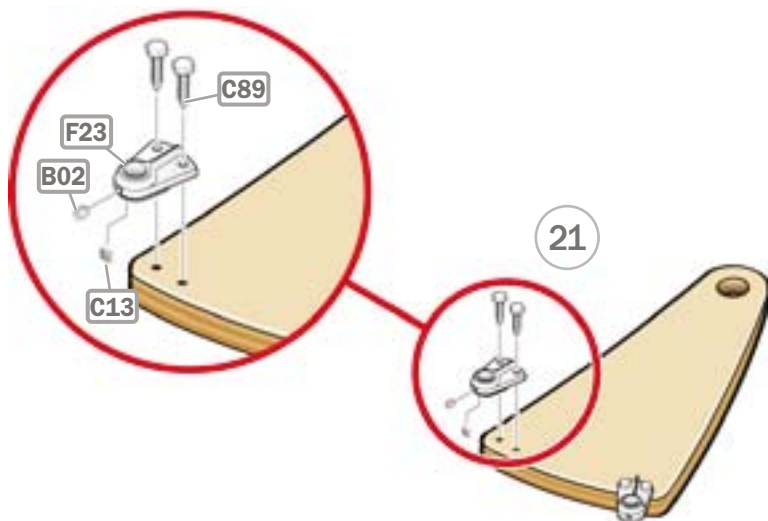
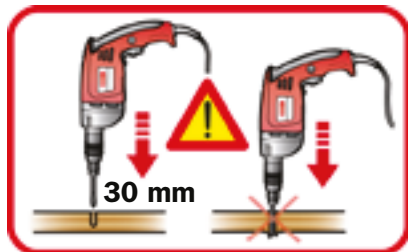

21

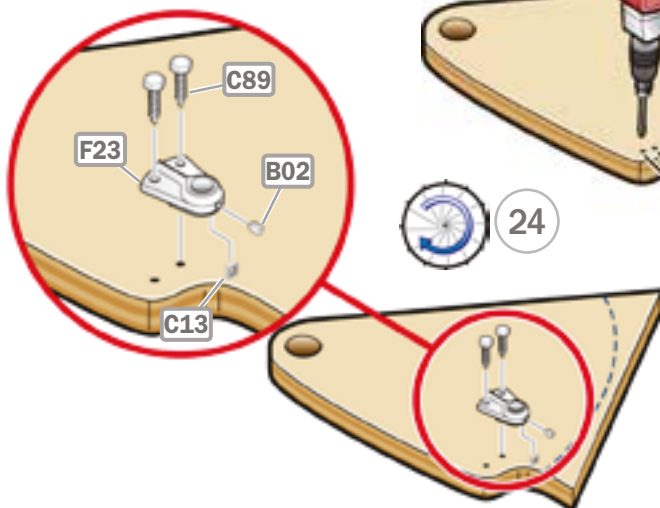
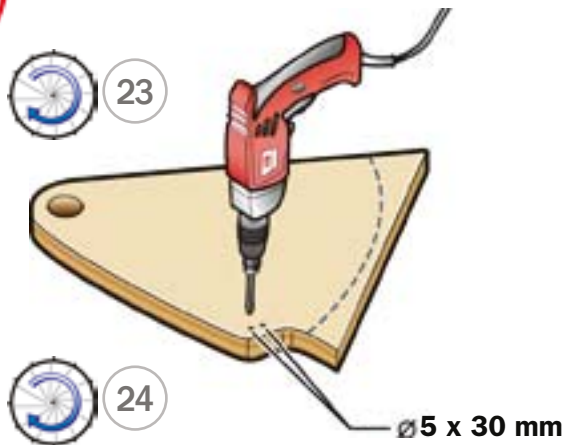
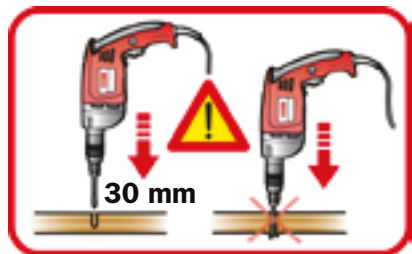



22

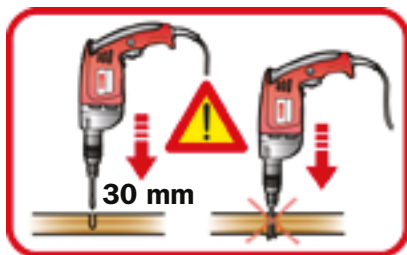

23

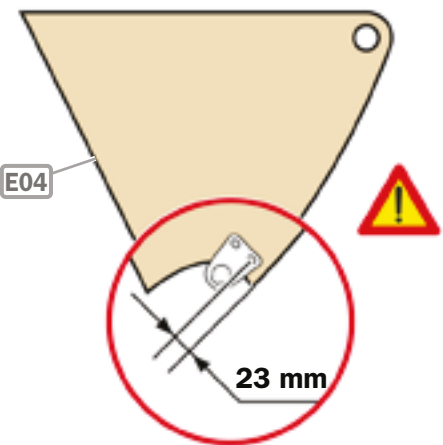
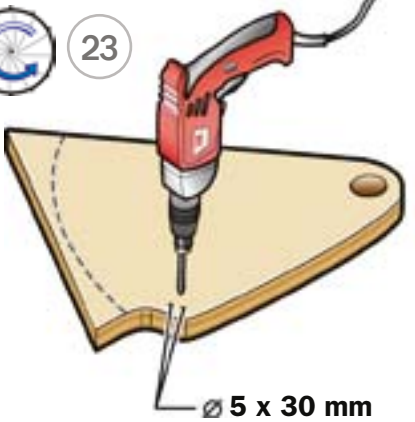

24

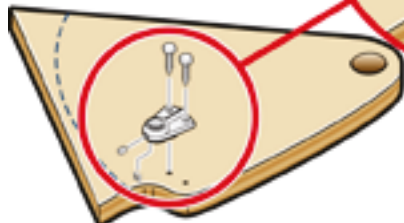
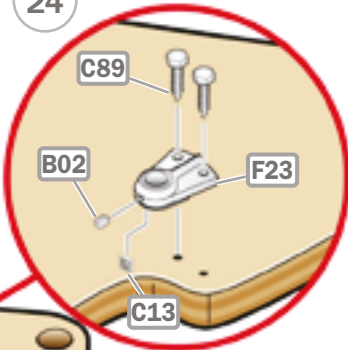

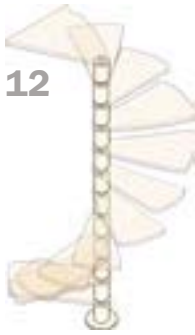

24-25

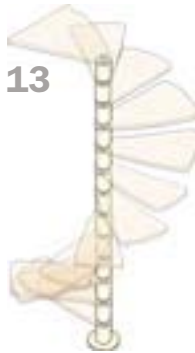

26-27

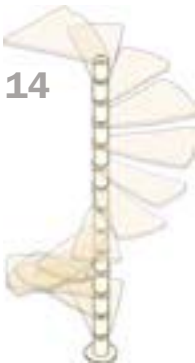

28-29



H	D47	D45
240	12	0
241	12	2
242	12	4
243	12	6
244	12	8
245	12	10
246	12	12
247	12	14
248	12	16
249	12	18
250	12	20
251	12	22
252	12	24
253	12	26
254	12	28
255	12	30
256	12	32
257	12	34
258	12	36
259	12	38
260	12	40
261	12	42
262	12	44
263	12	46
264	12	48
265	12	50
266	12	52
267	12	54
268	12	56
269	12	58
270	12	60
271	12	62
272	12	64
273	12	66
274	12	68
275	12	70
276	12	72
277	12	74
278	12	76
279	12	78
280	12	80
281	12	82
282	12	84

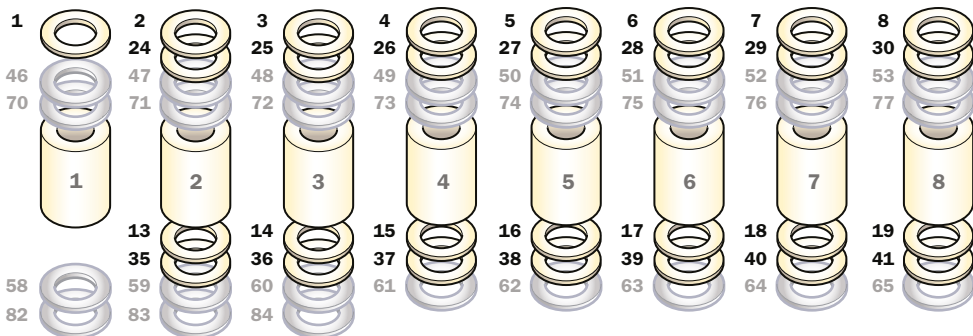
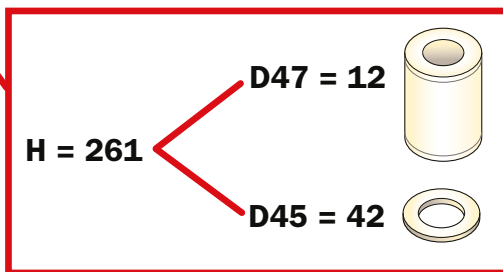
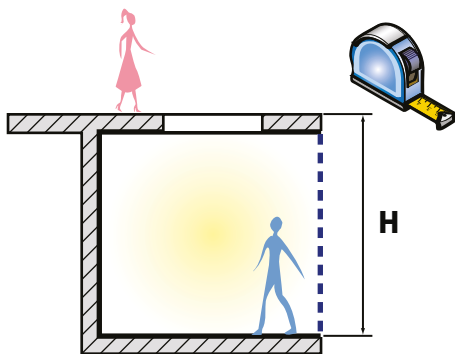

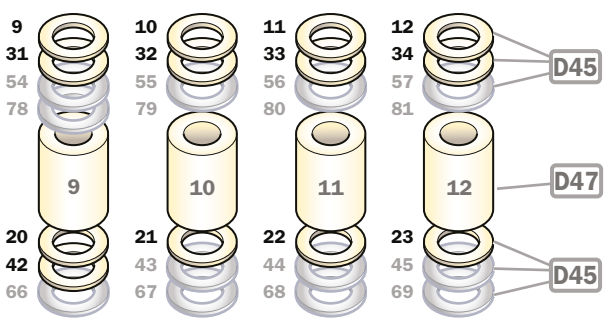
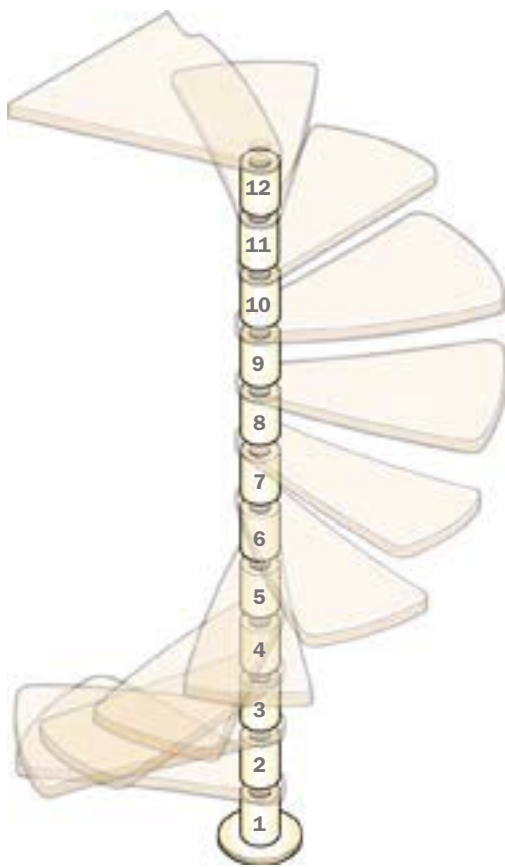

H	D47	D45
260	13	0
261	13	2
262	13	4
263	13	6
264	13	8
265	13	10
266	13	12
267	13	14
268	13	16
269	13	18
270	13	20
271	13	22
272	13	24
273	13	26
274	13	28
275	13	30
276	13	32
277	13	34
278	13	36
279	13	38
280	13	40
281	13	42
282	13	44
283	13	46
284	13	48
285	13	50
286	13	52
287	13	54
288	13	56
289	13	58
290	13	60
291	13	62
292	13	64
293	13	66
294	13	68
295	13	70
296	13	72
297	13	74
298	13	76
299	13	78
300	13	80
301	13	82
302	13	84
303	13	86
304	13	88
305	13	90

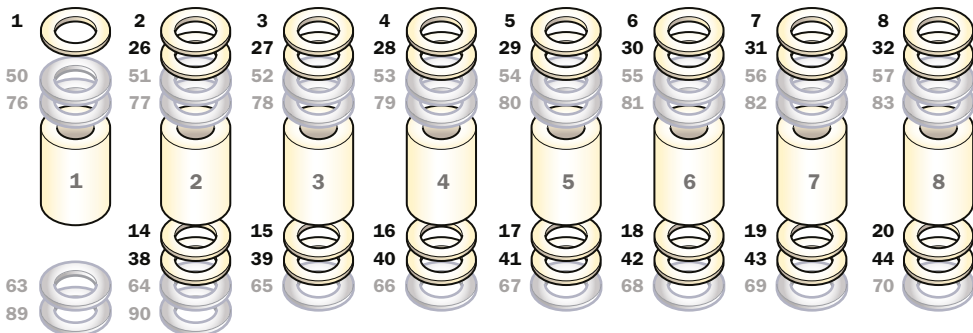
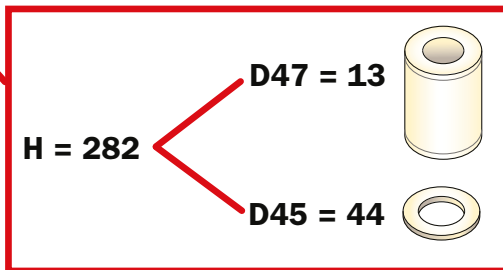
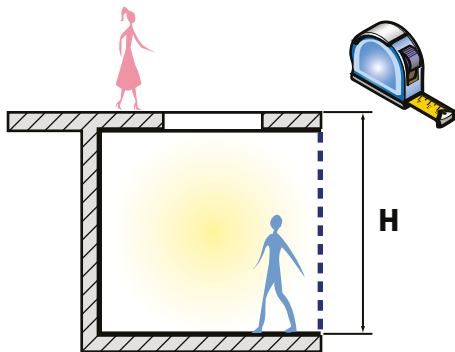

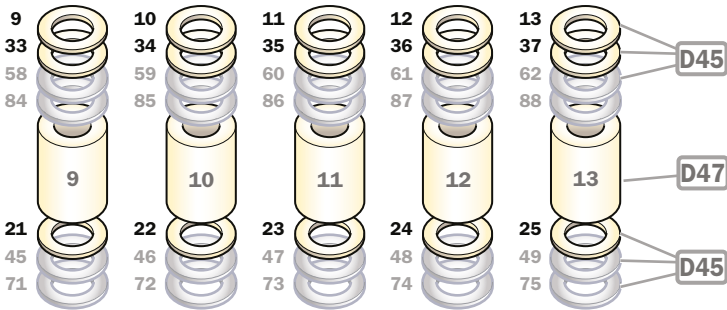
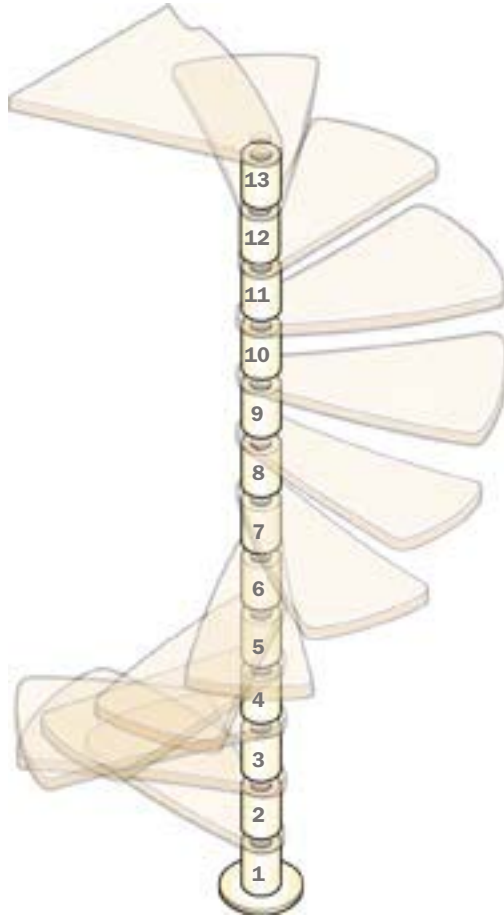

H	D47	D45
280	14	1
281	14	3
282	14	5
283	14	7
284	14	9
285	14	11
286	14	13
287	14	15
288	14	17
289	14	19
290	14	21
291	14	23
292	14	25
293	14	27
294	14	29
295	14	31
296	14	33
297	14	35
298	14	37
299	14	39
300	14	41
301	14	43
302	14	45
303	14	47
304	14	49
305	14	51
306	14	53
307	14	55
308	14	57
309	14	59
310	14	61
311	14	63
312	14	65
313	14	67
314	14	69
315	14	71
316	14	73
317	14	75
318	14	77
319	14	79
320	14	81
321	14	83
322	14	85
323	14	87
324	14	89
325	14	91

H	D47	D45
326	14	93
327	14	95
328	14	97

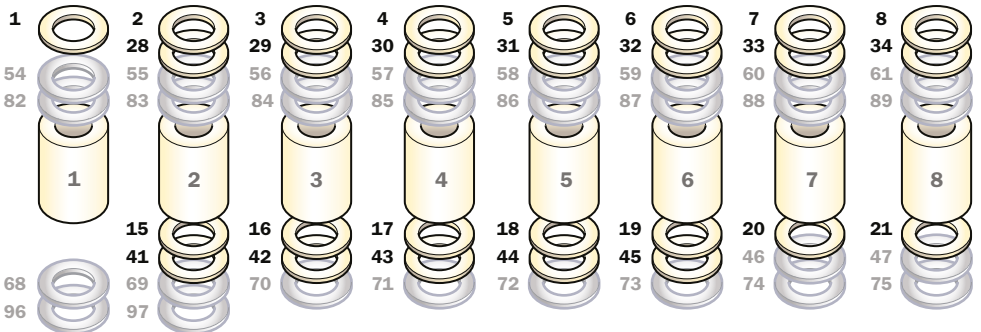
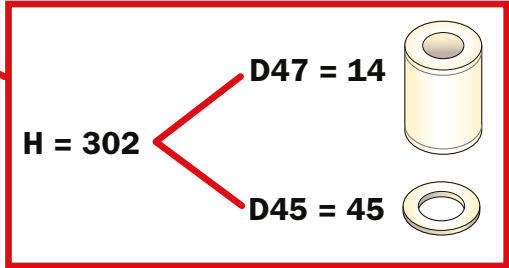
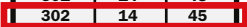
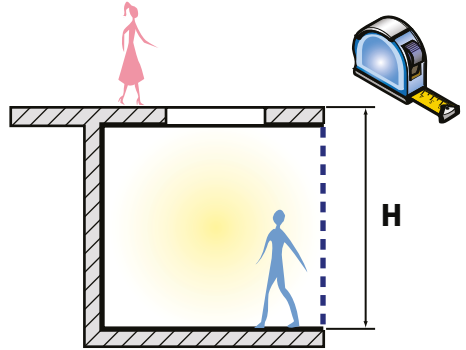

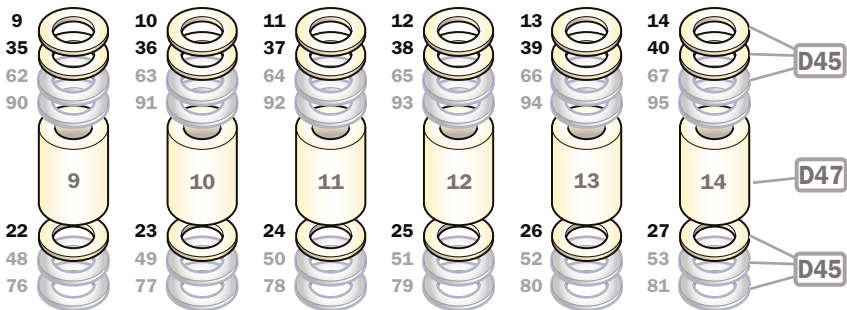
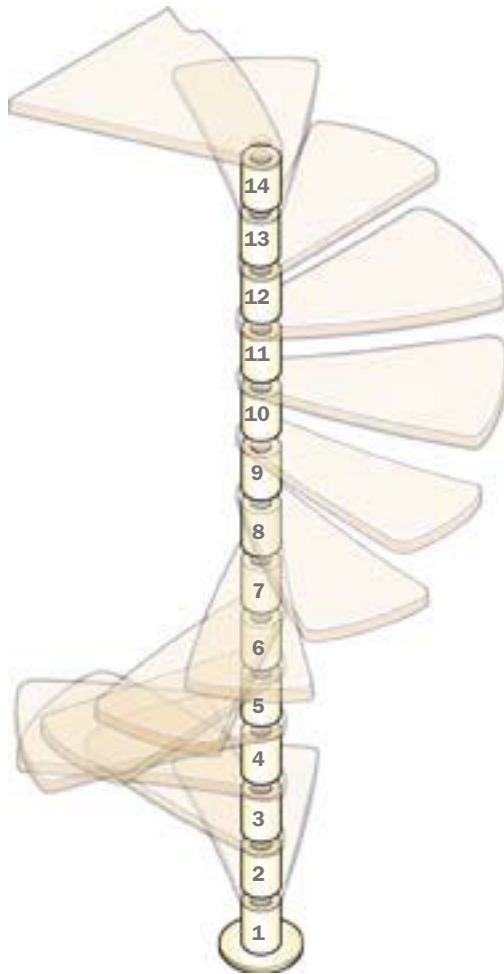

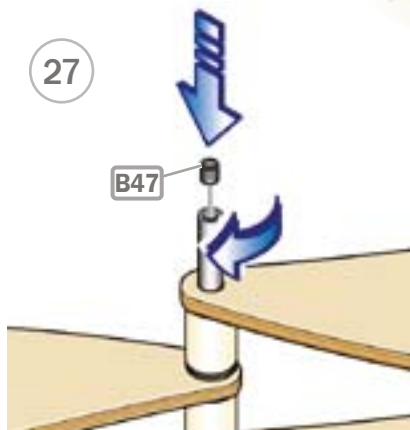
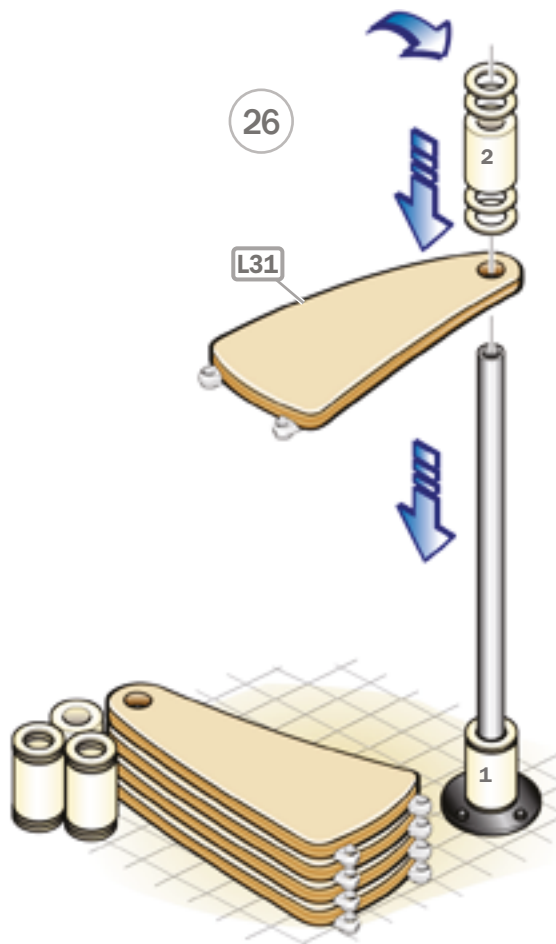
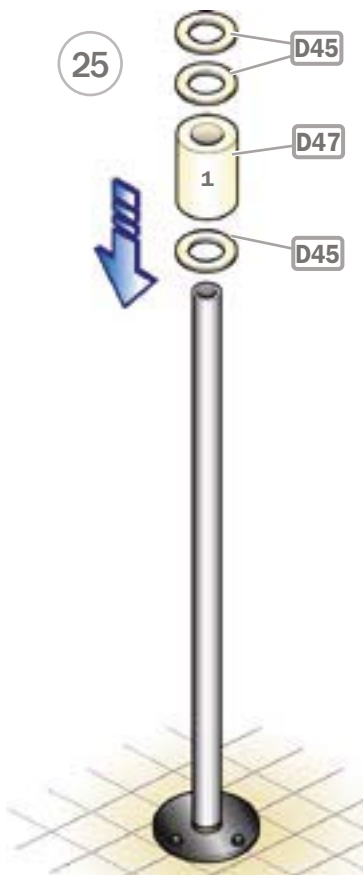

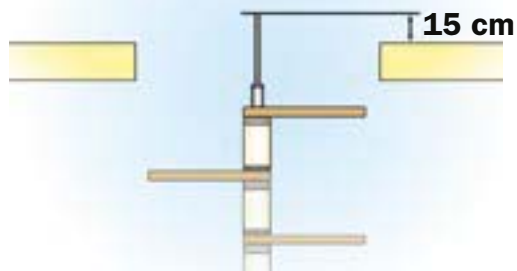
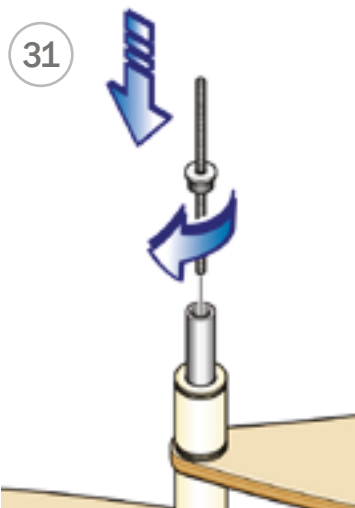
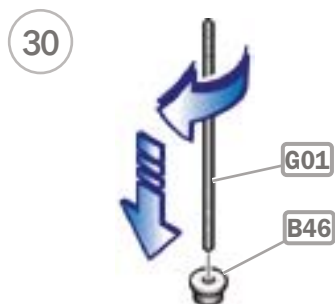

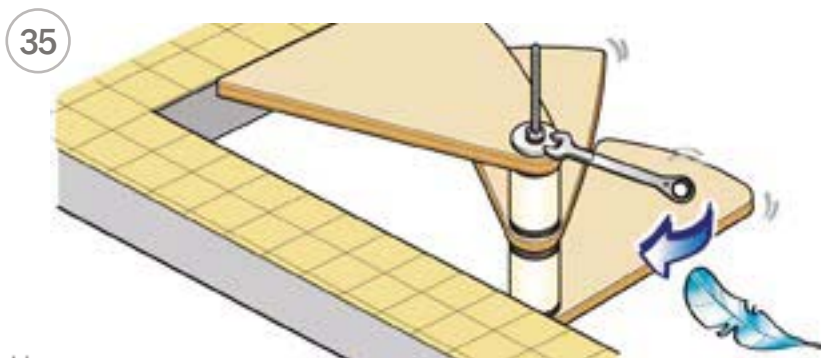
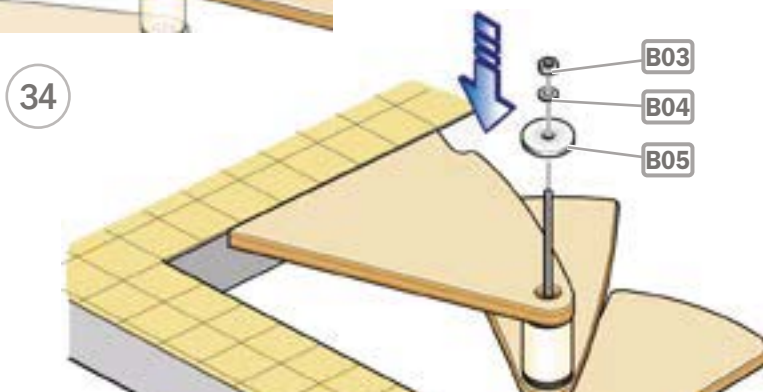
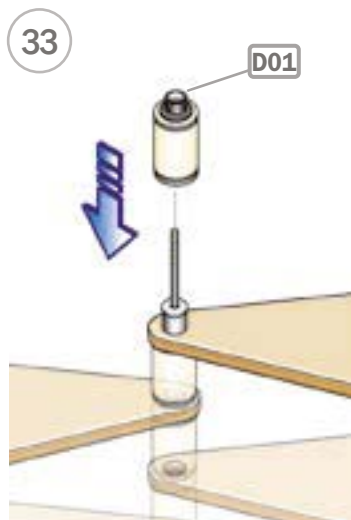
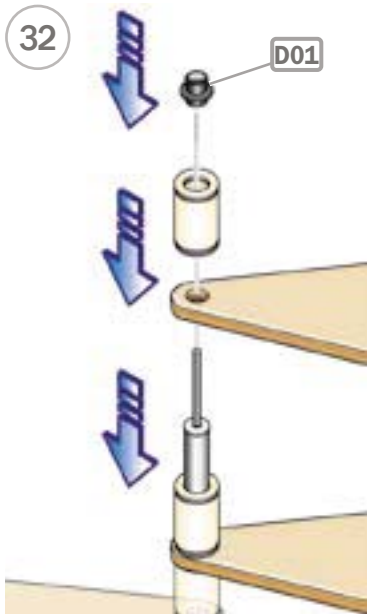

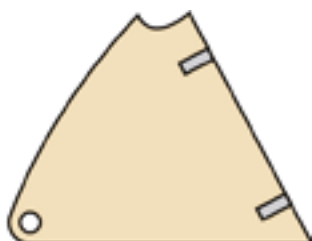

36

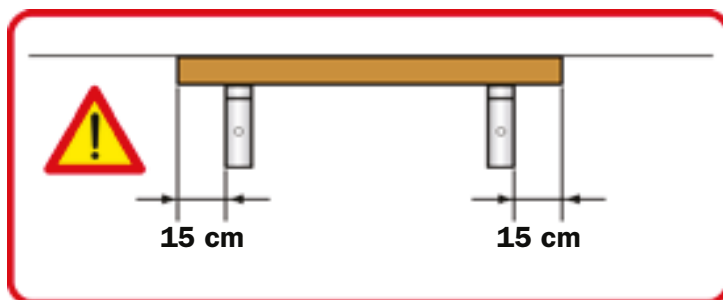
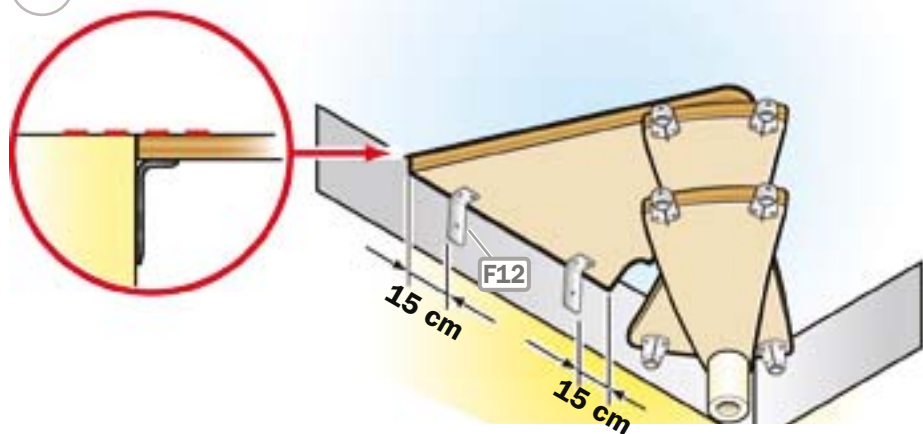

37

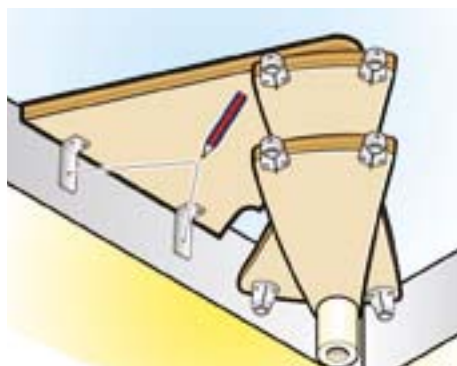

38

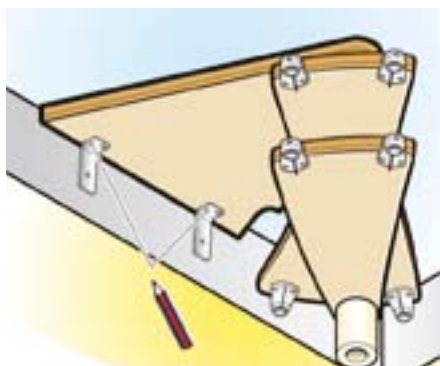

39

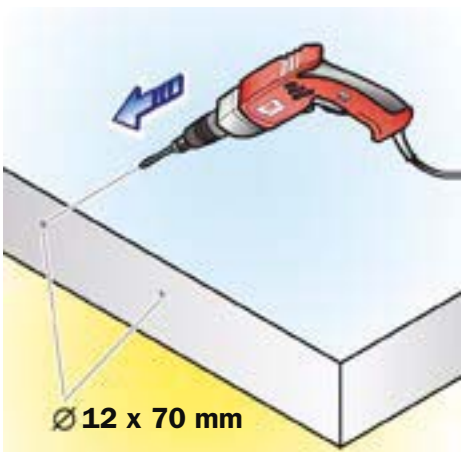

40

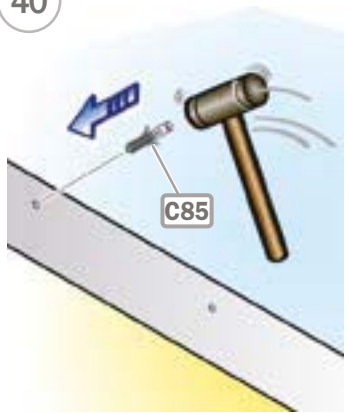

41

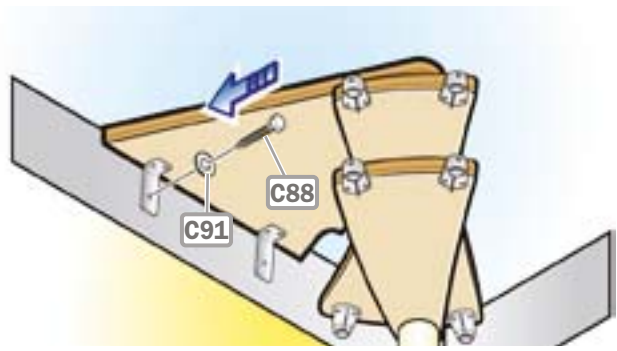

42

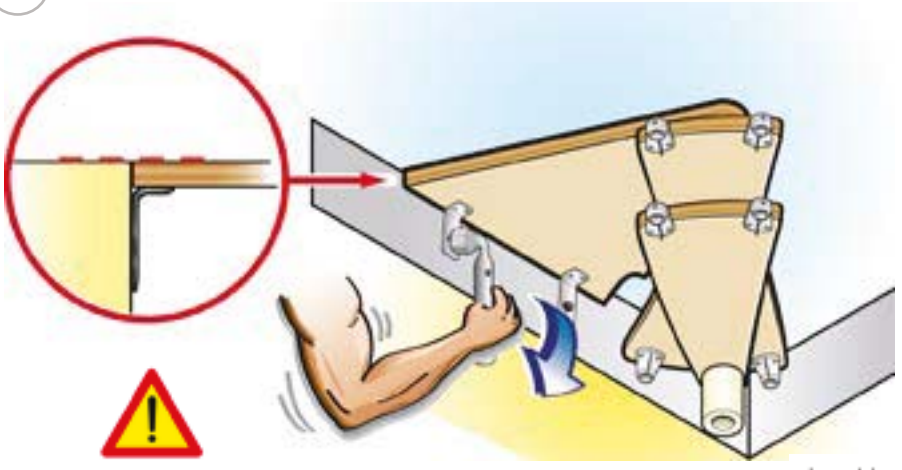

43

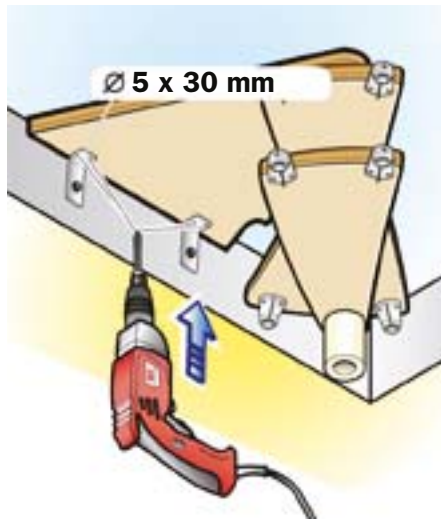

44

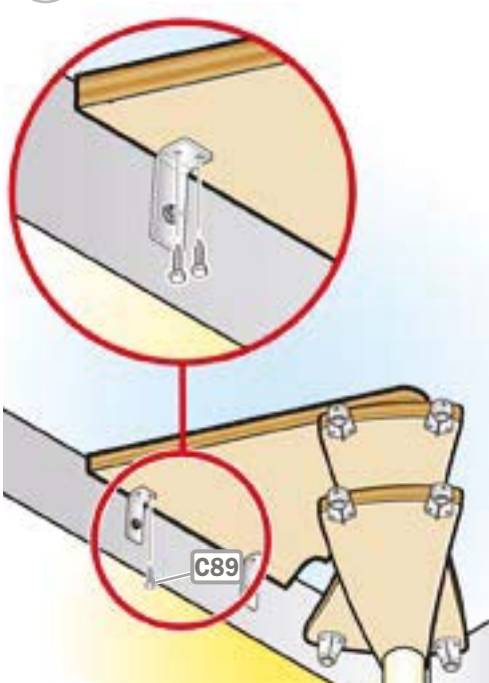

45

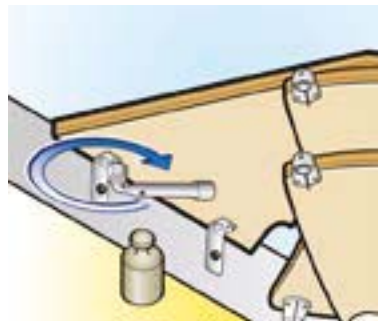

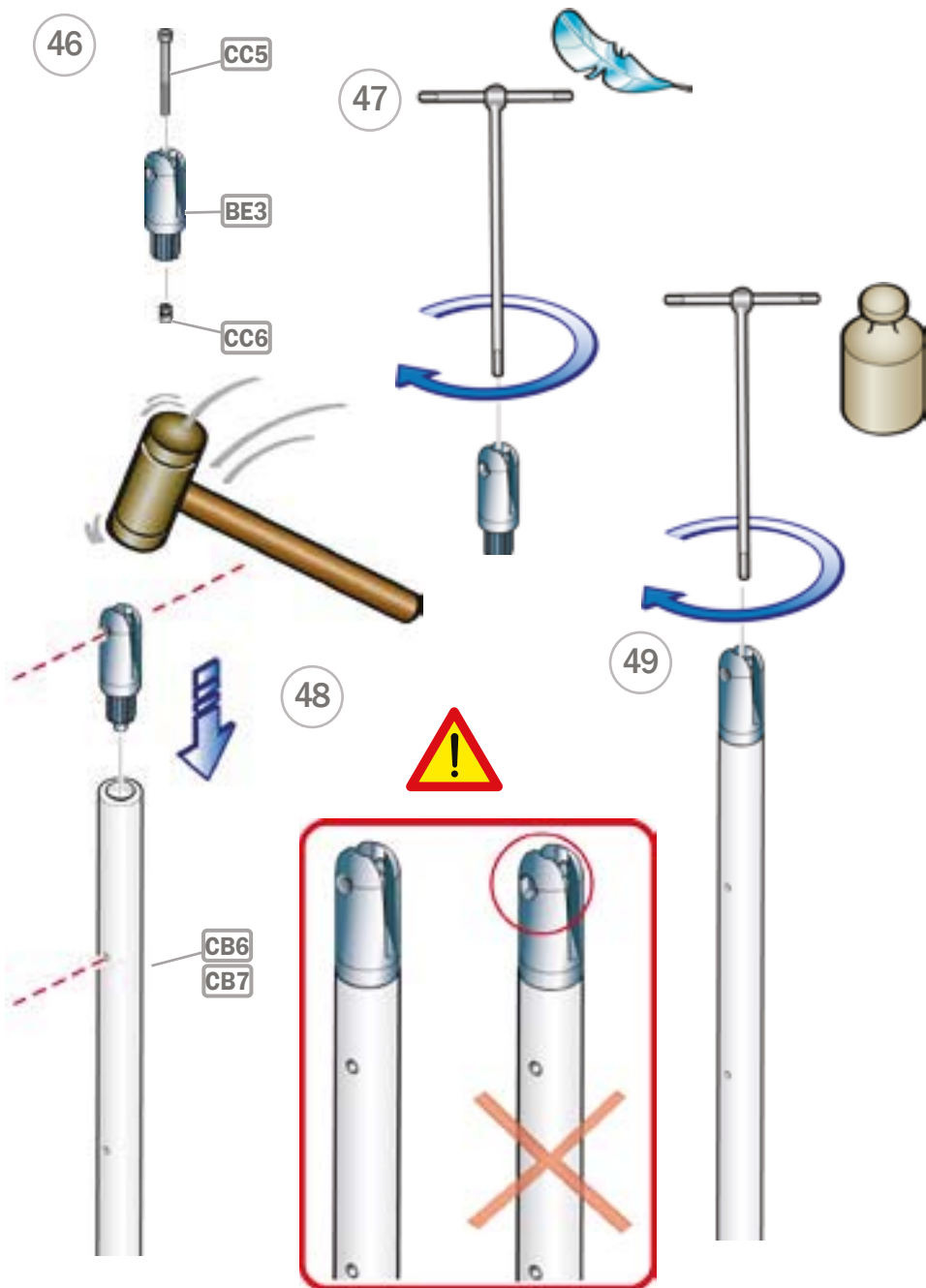

50

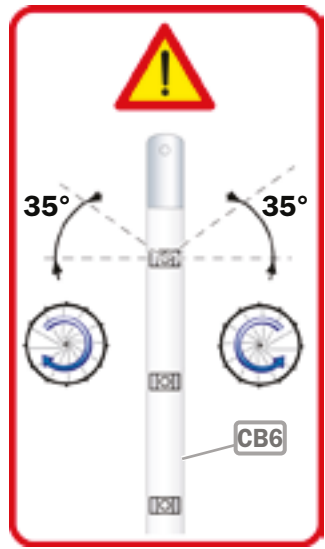
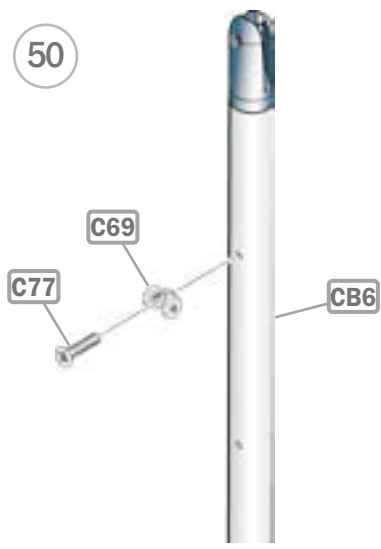

51

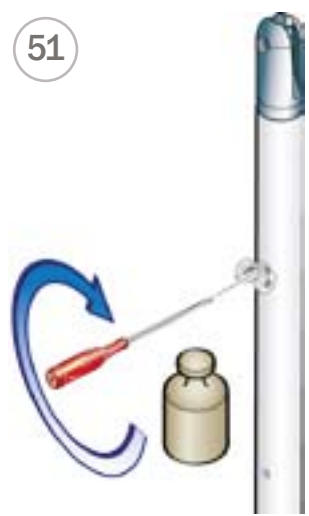

52

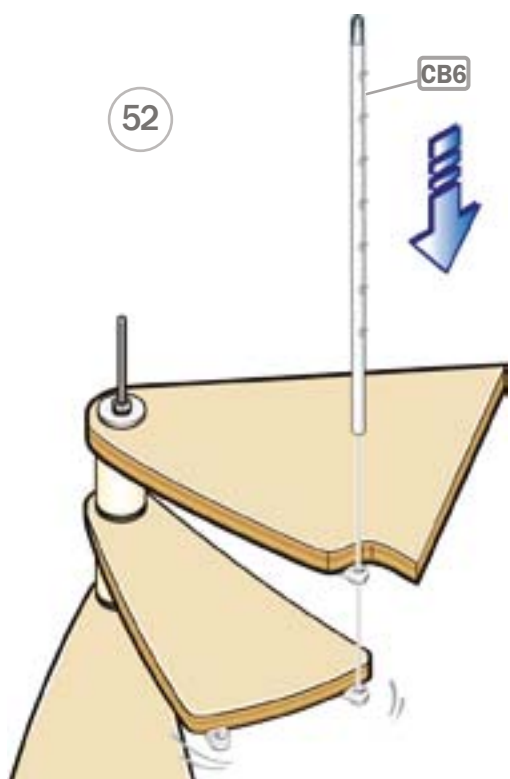

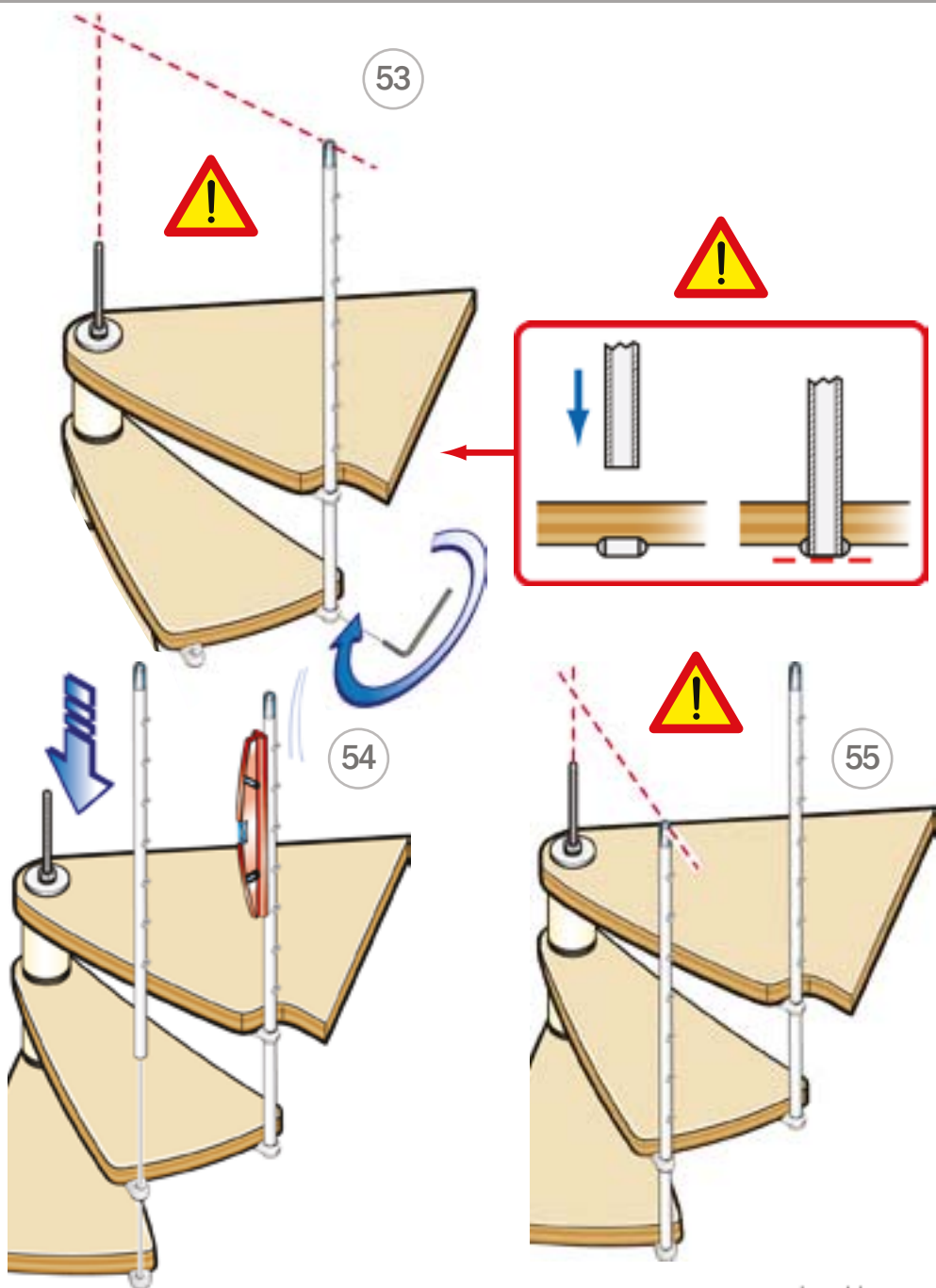

53

54

55

56

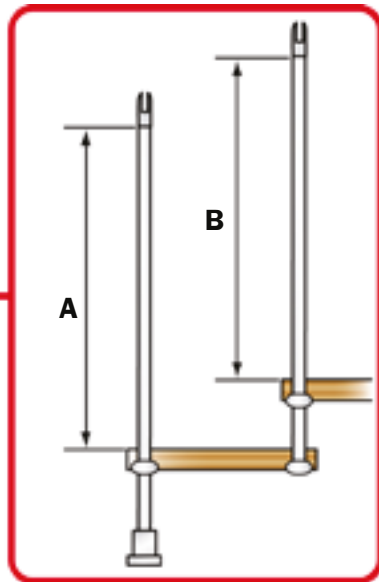
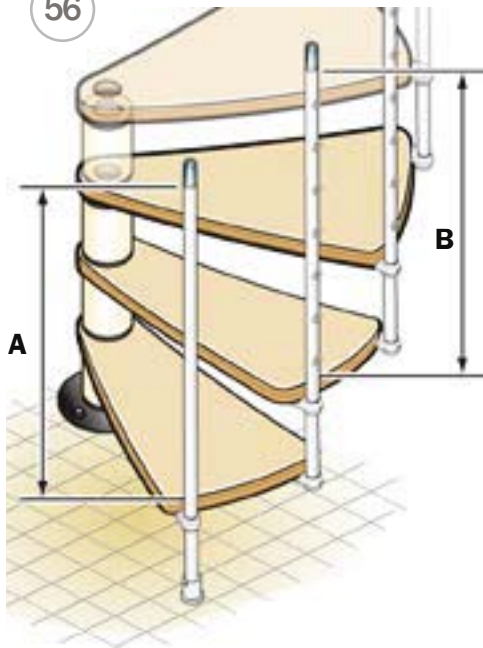

57

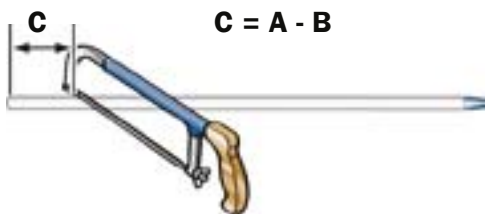

58



59

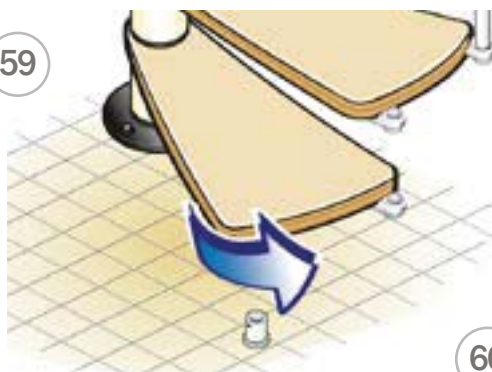

60

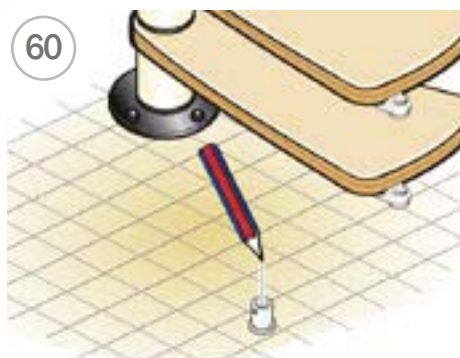

61

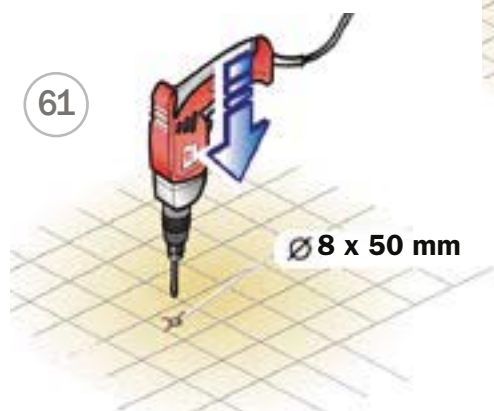

62



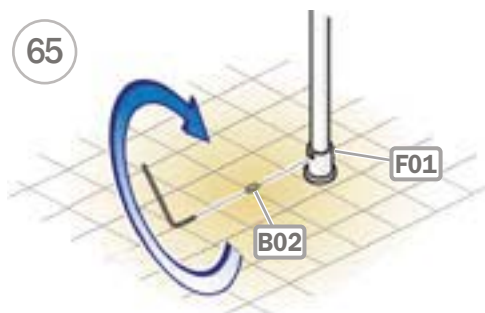

66

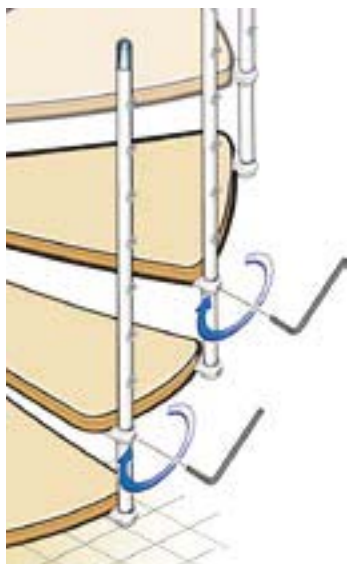

67

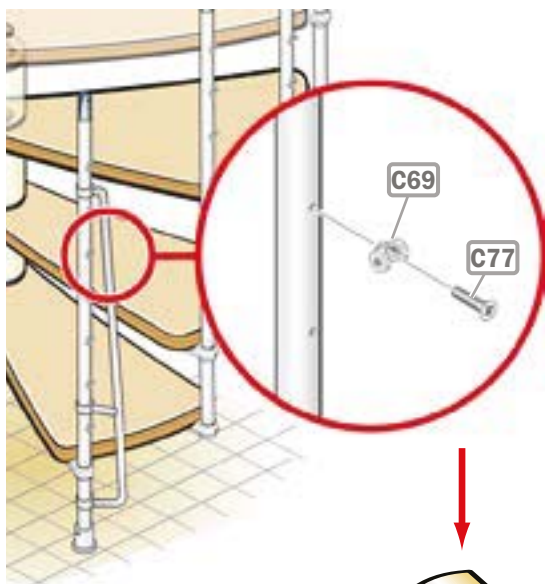

68

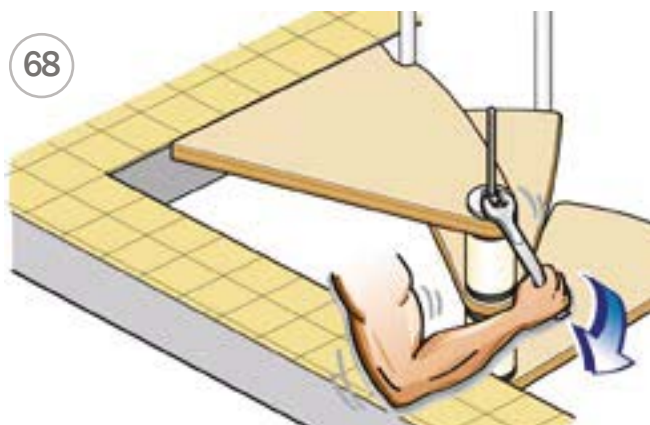

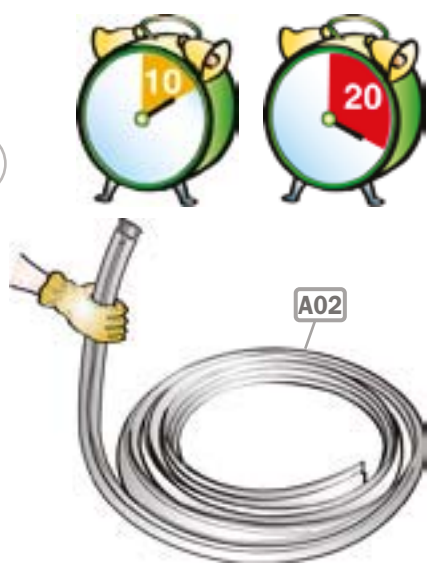
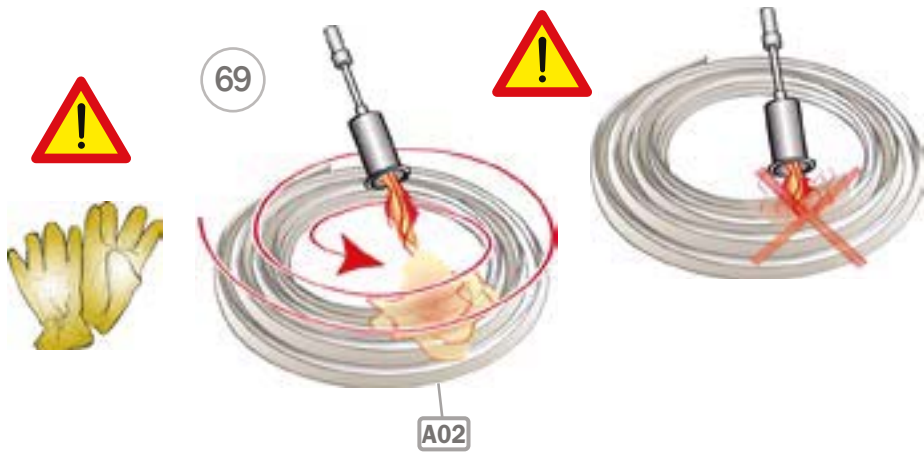

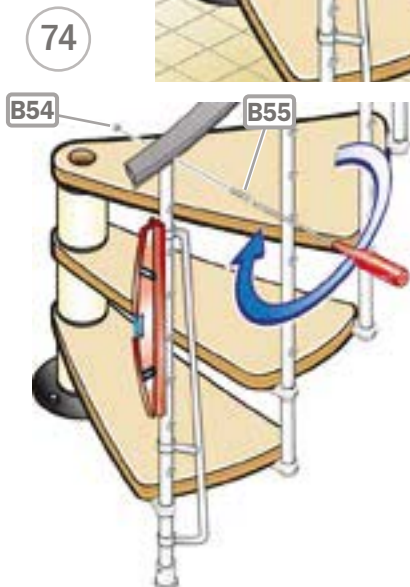
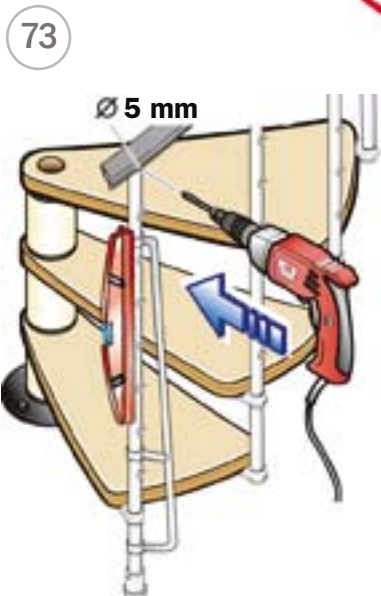
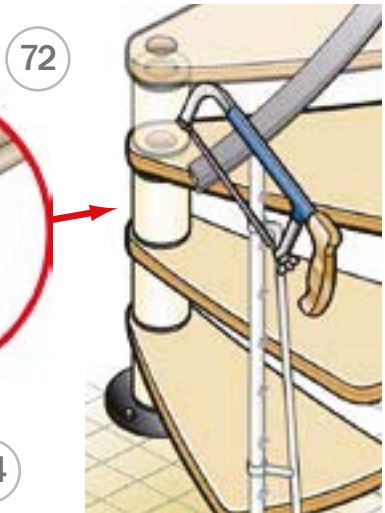
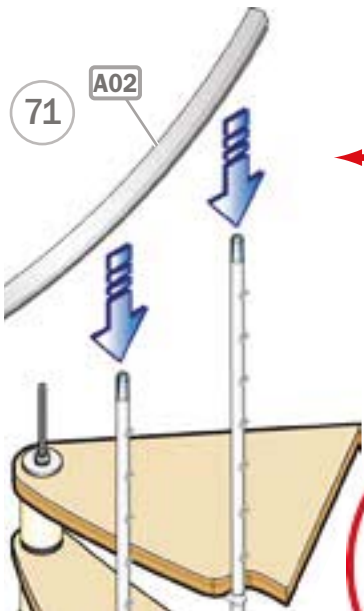

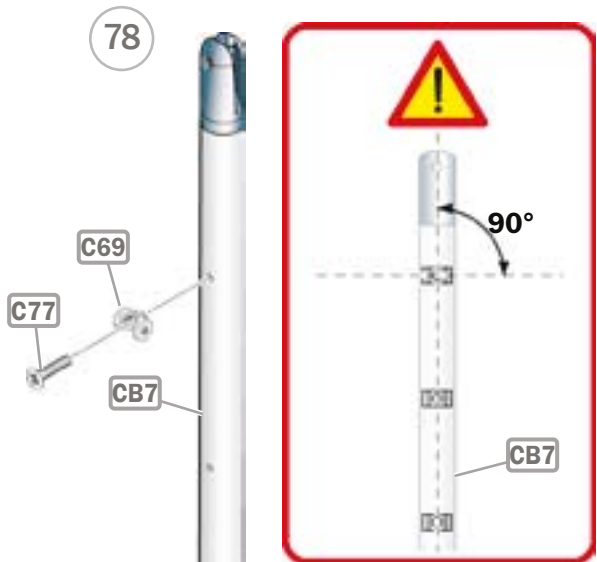
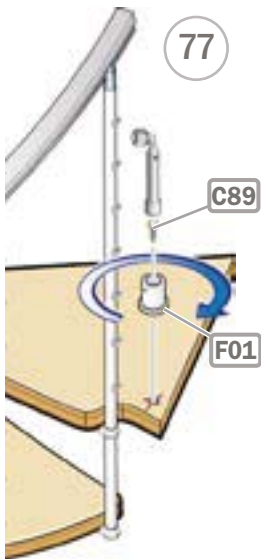
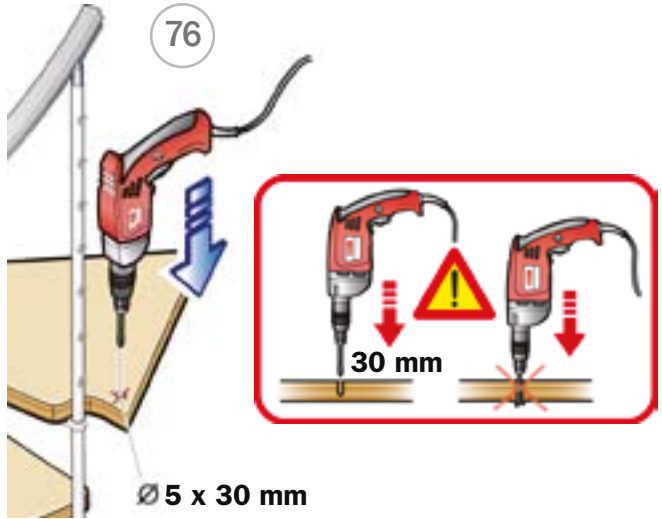
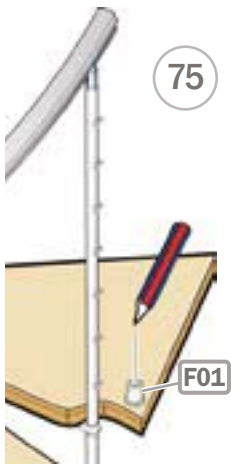

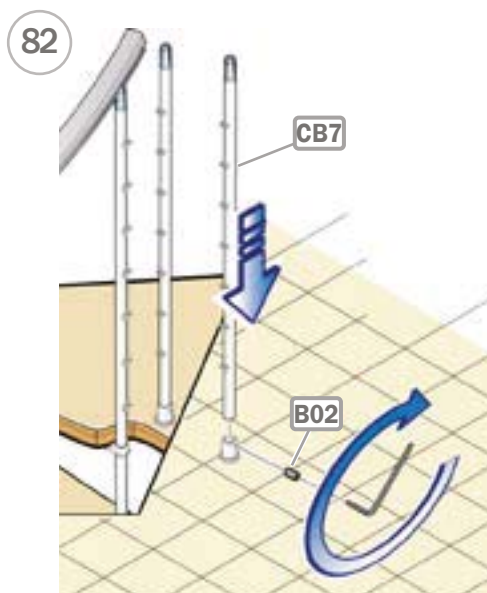
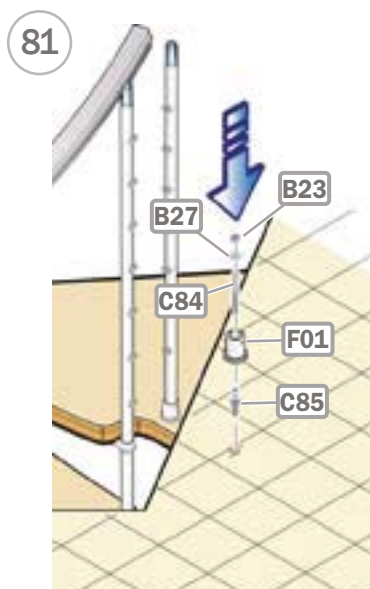
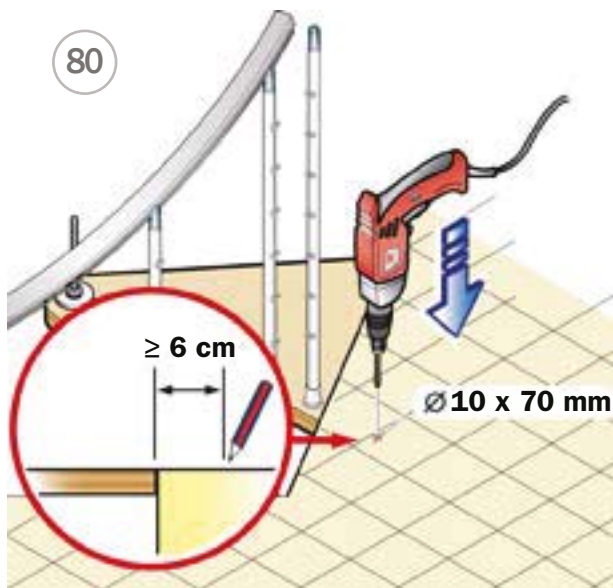
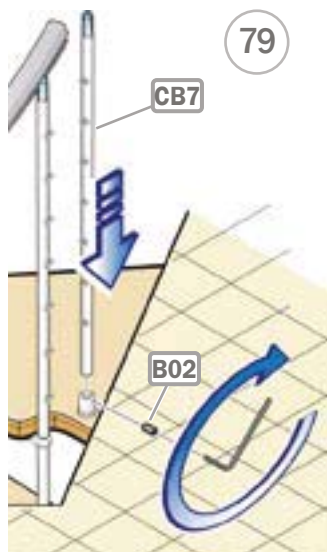

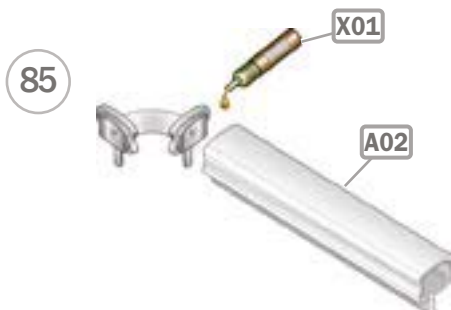
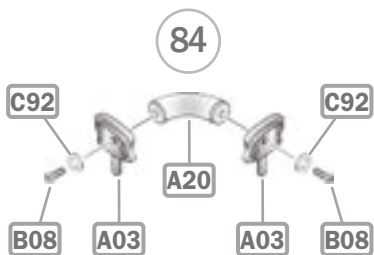

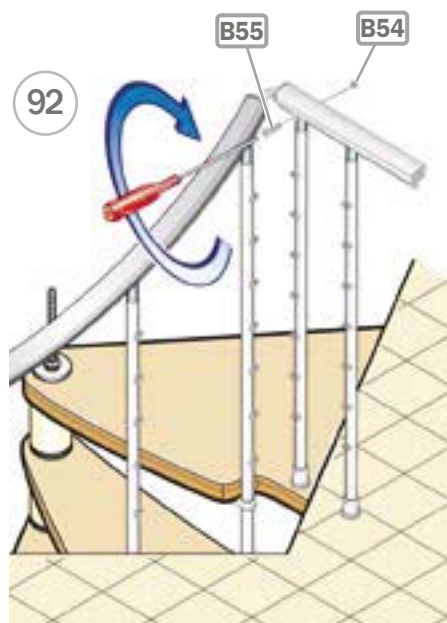
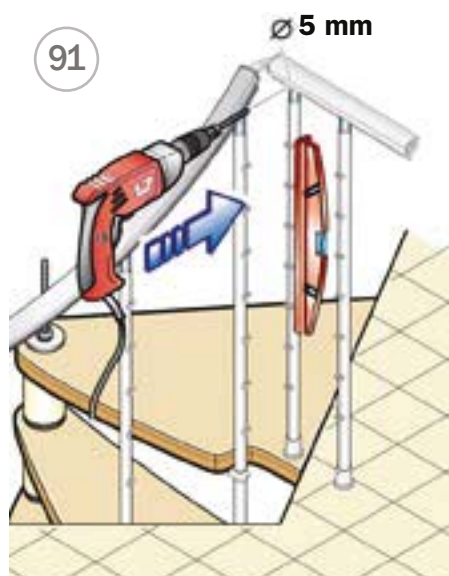

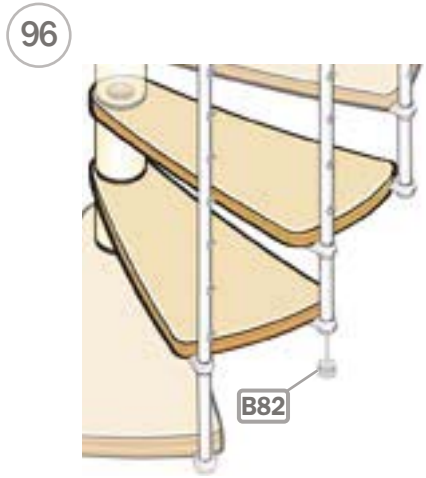
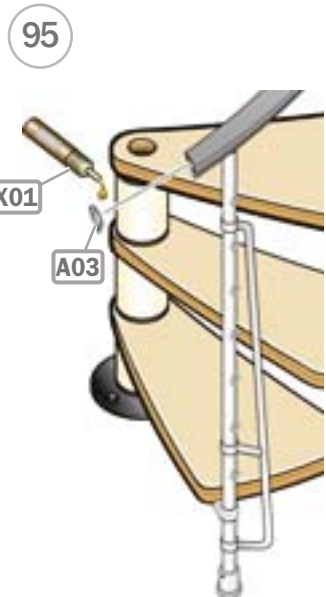
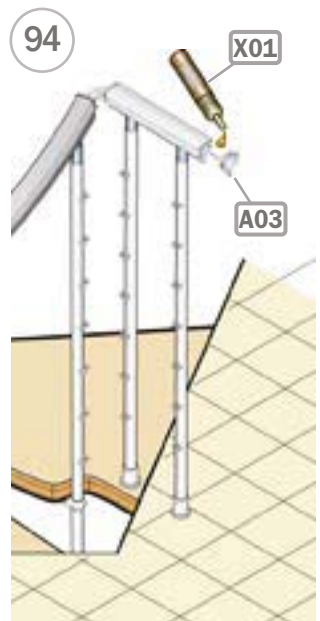
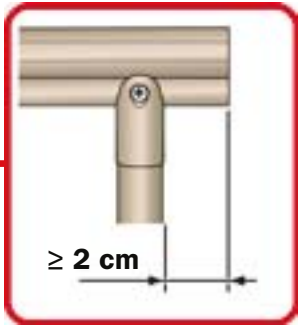
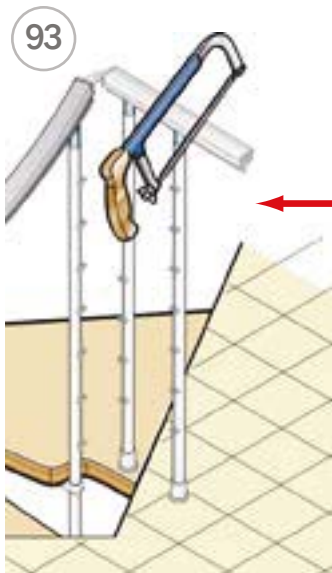

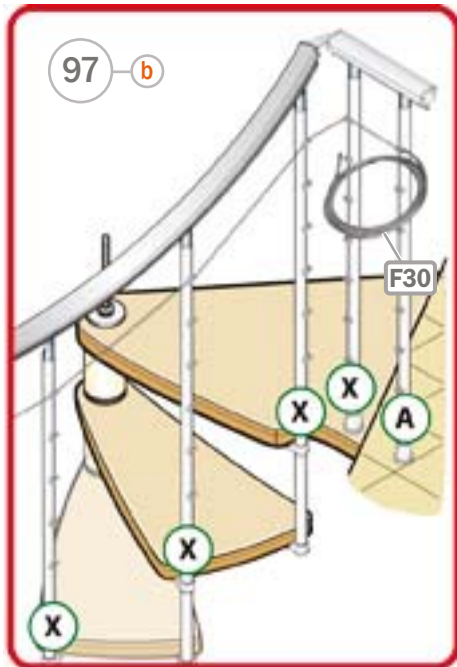
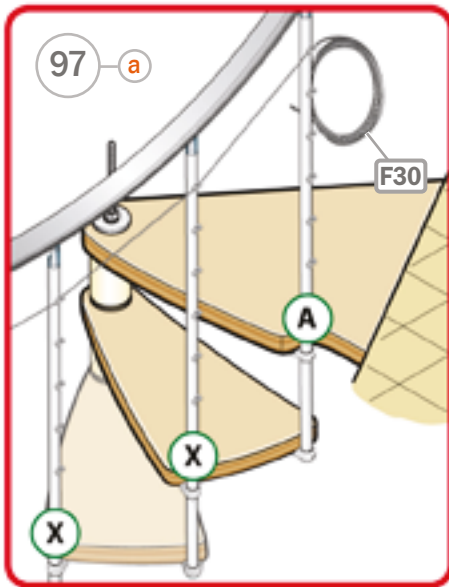

98 a

b

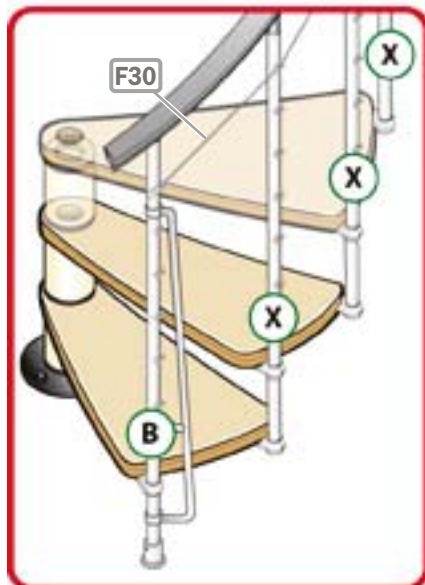

99

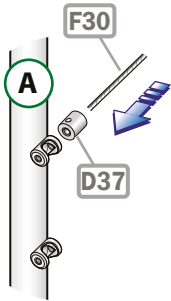

100

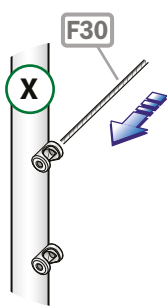

101

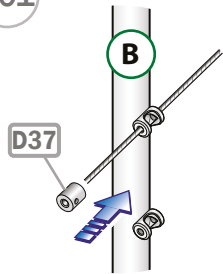

102

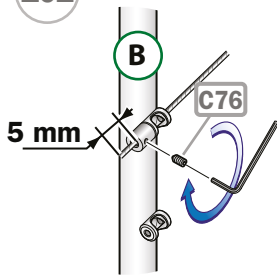

103

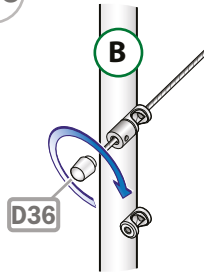

104

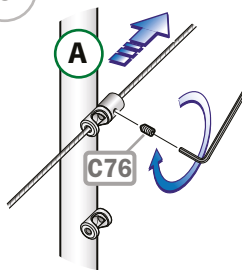

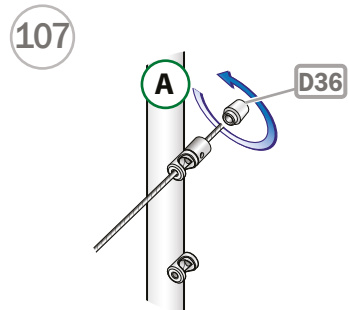
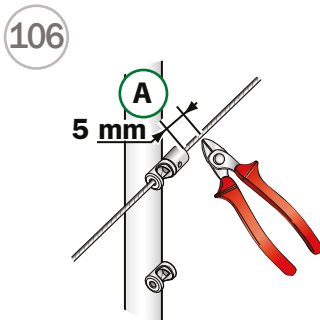
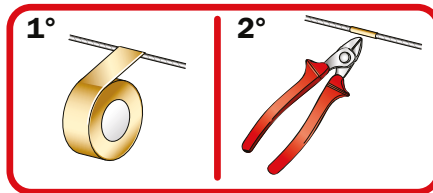
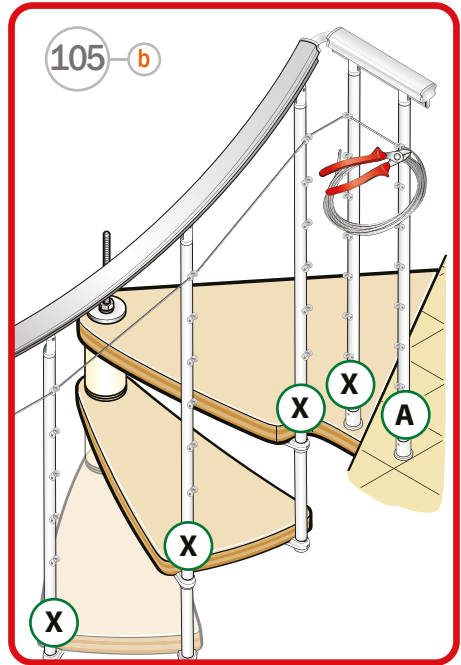
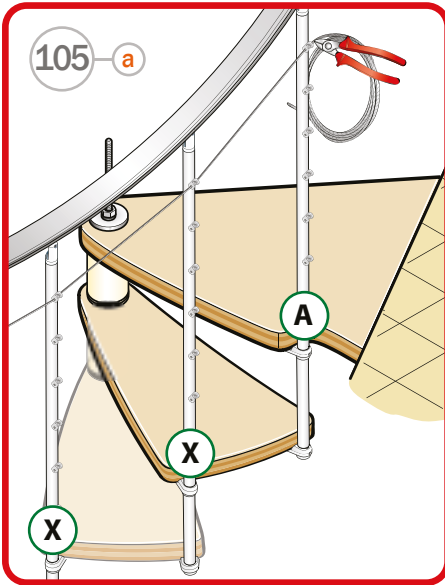



108 a

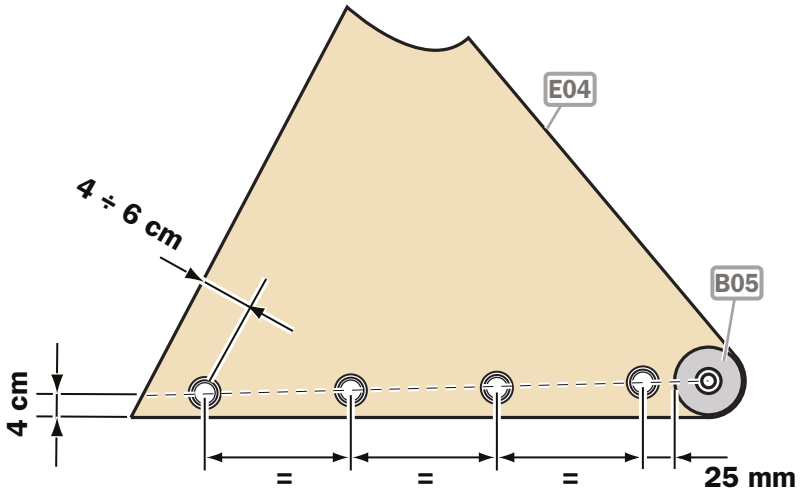

108 b

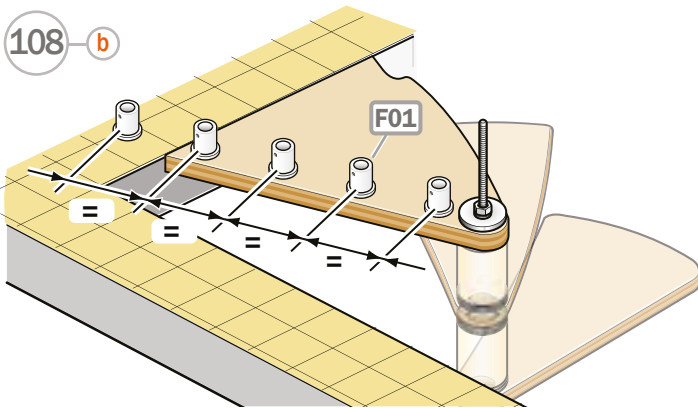

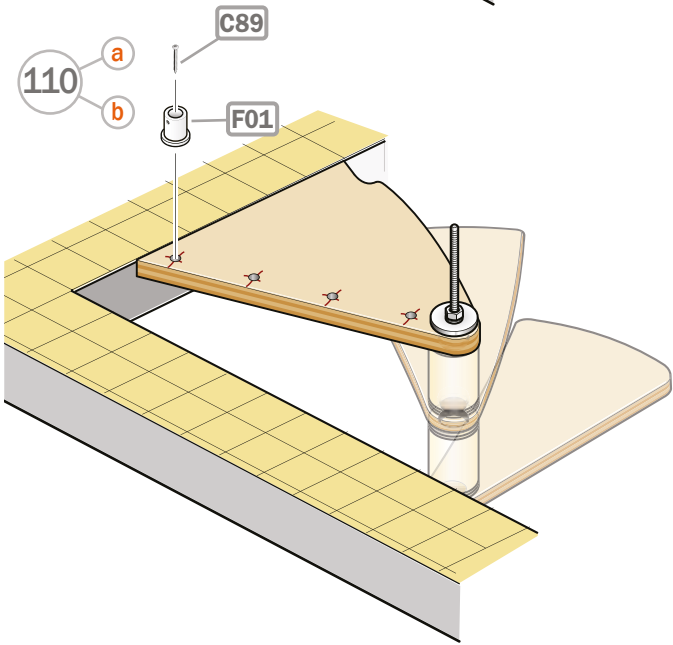
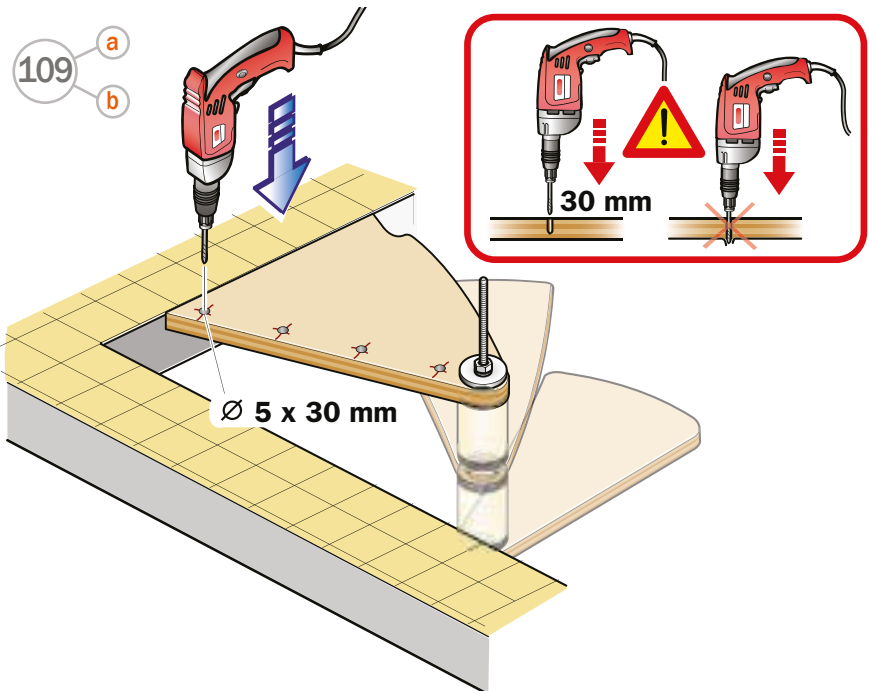

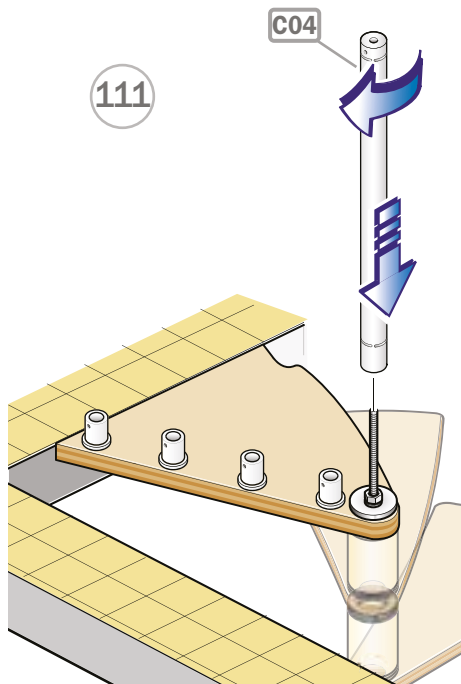

112

a

b

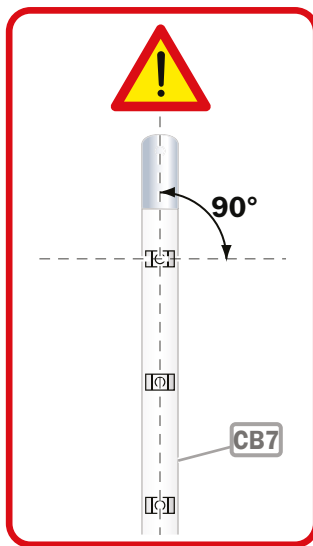
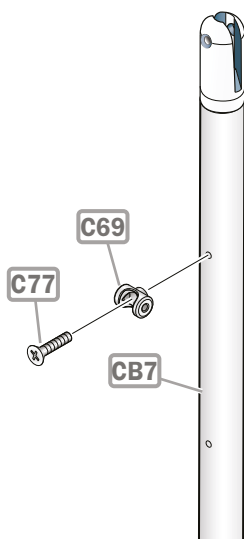

113 a
b

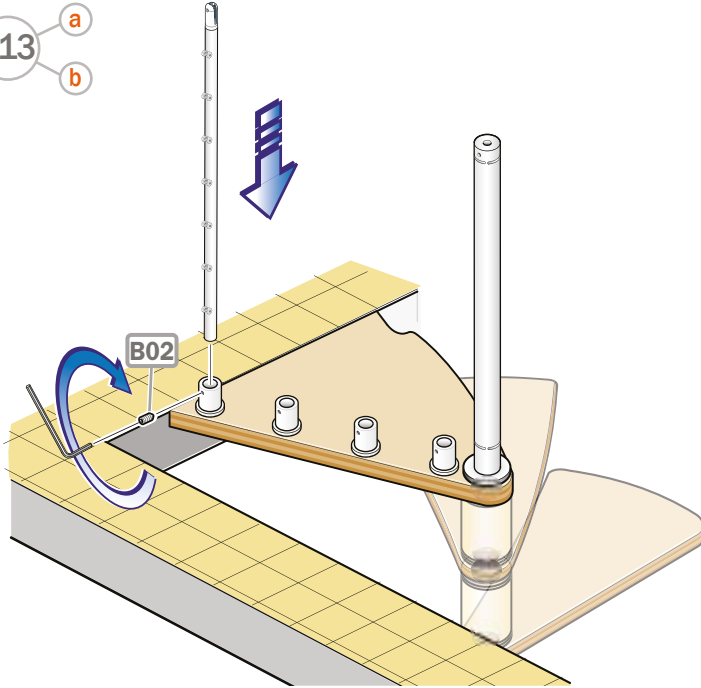

114 b

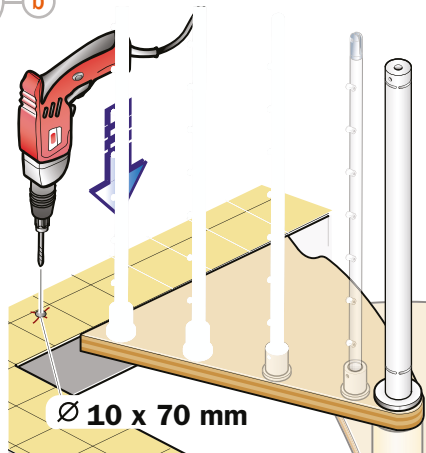

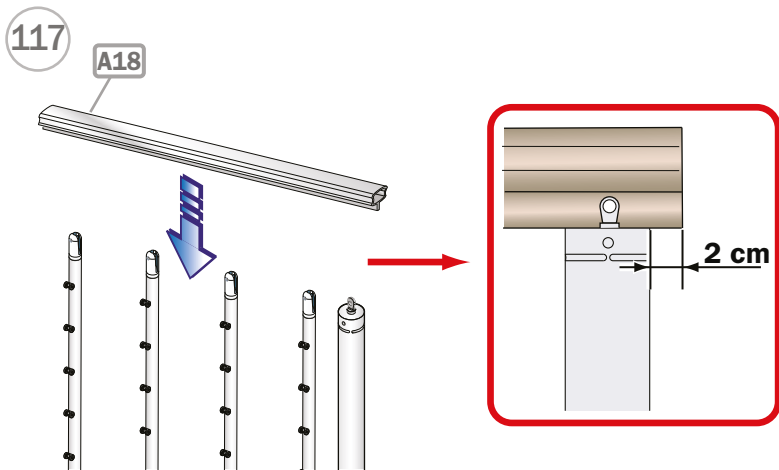
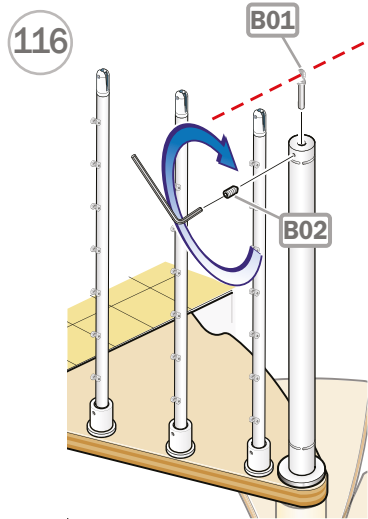
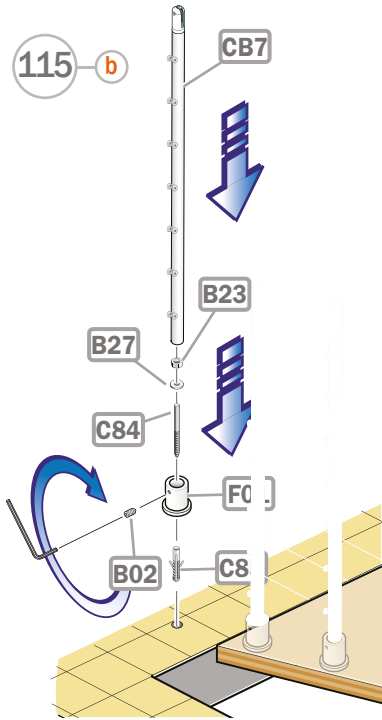

118

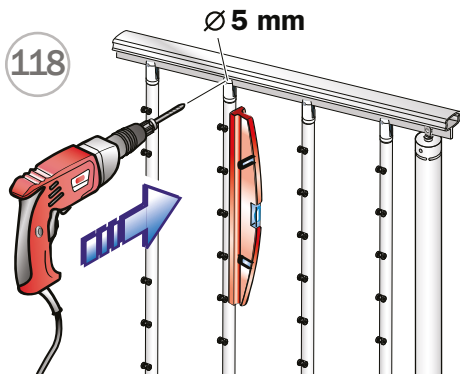

119

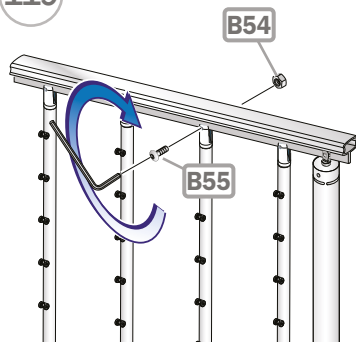

120 a

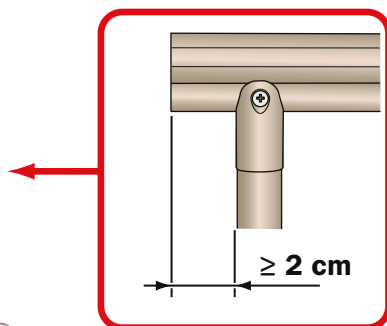
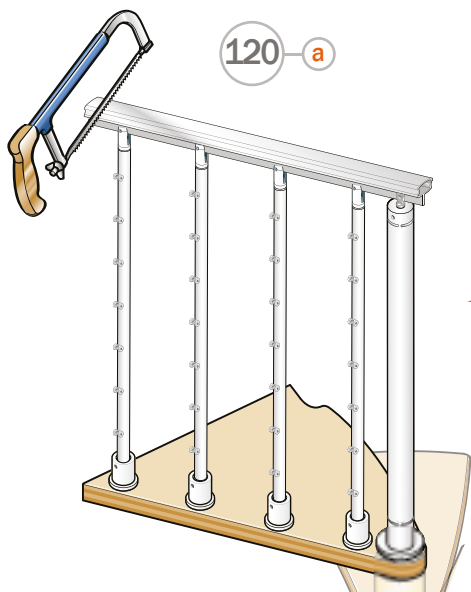

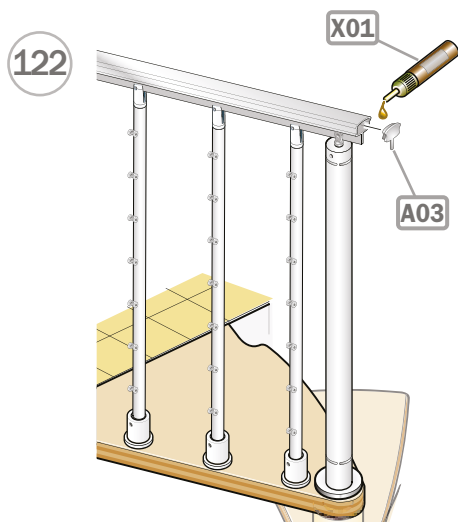
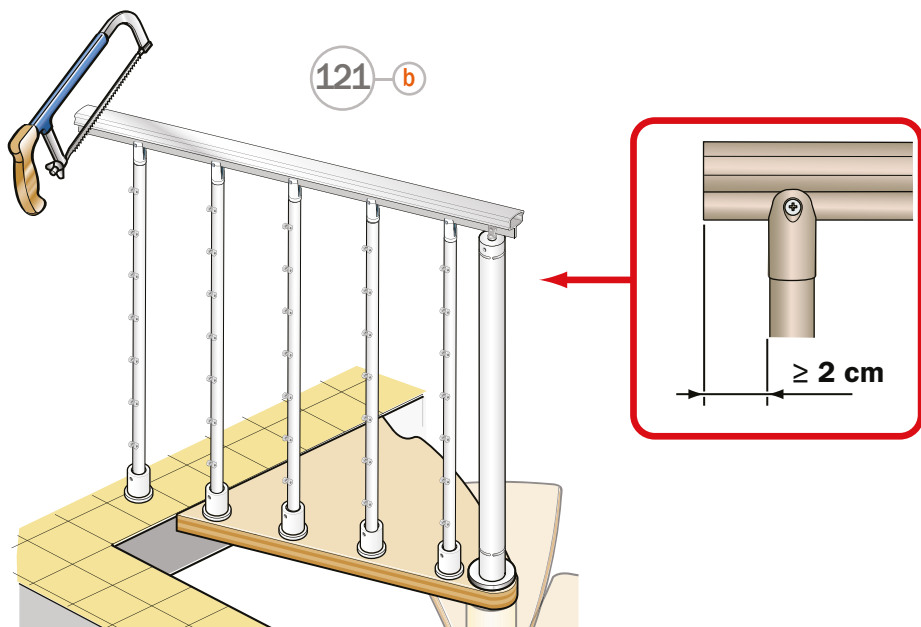

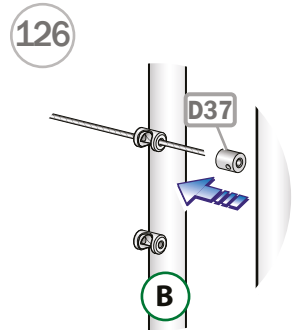
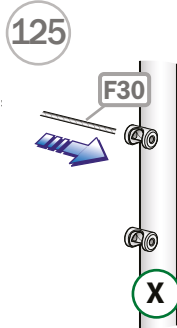
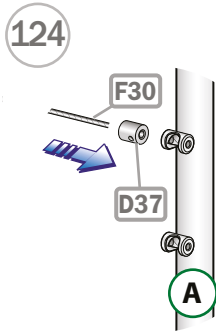
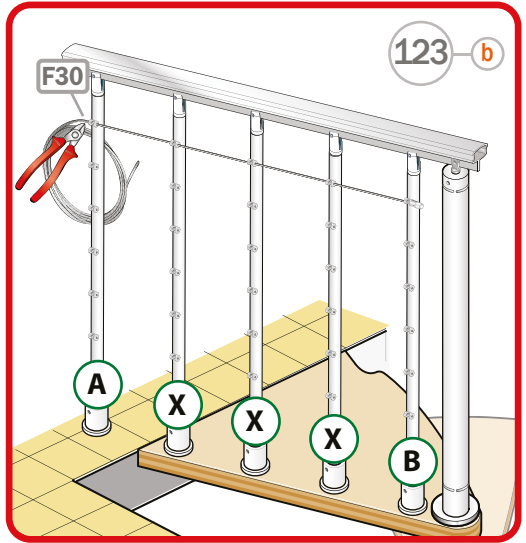
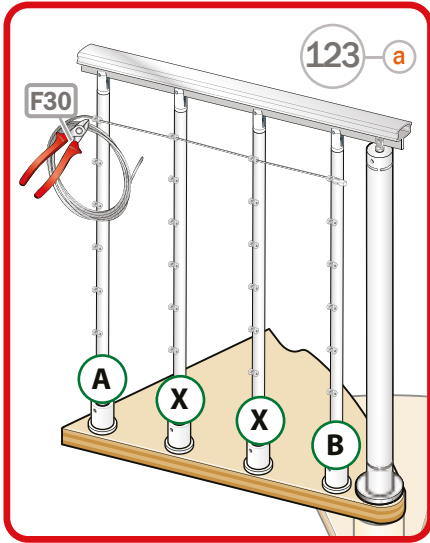

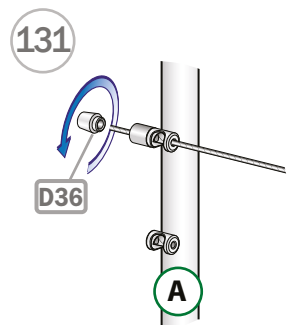
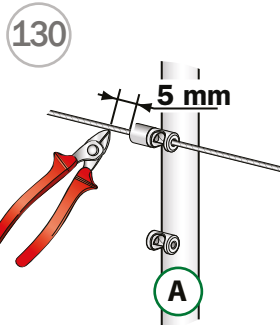
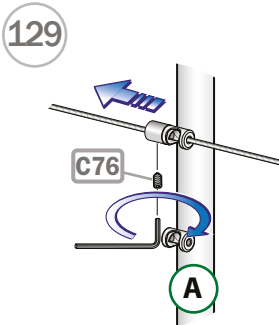
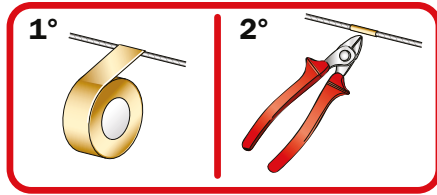
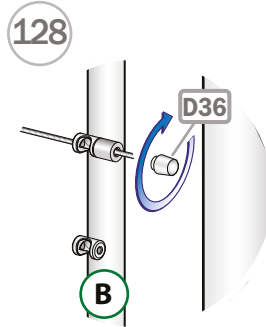
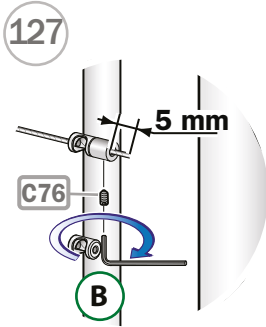

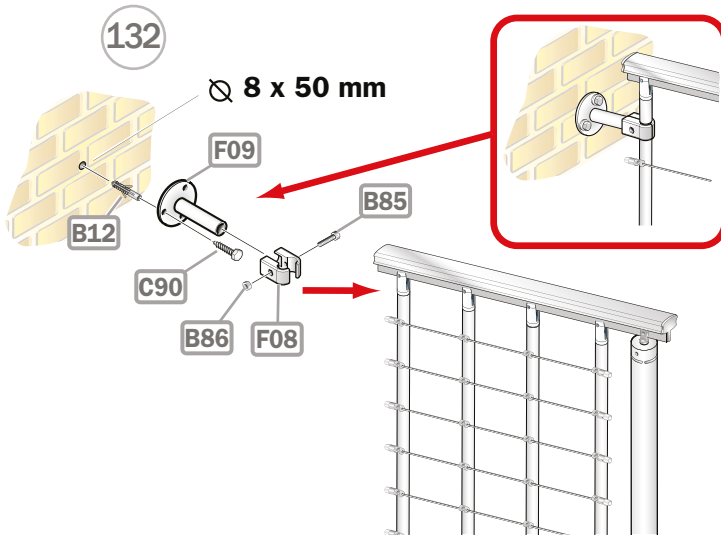

133

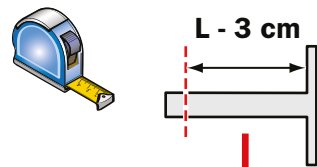
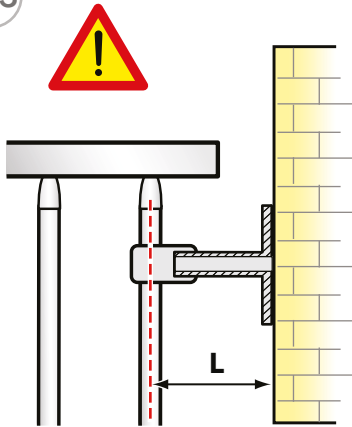

134

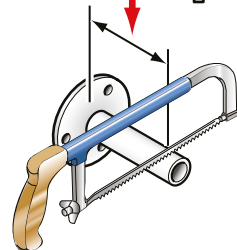

135

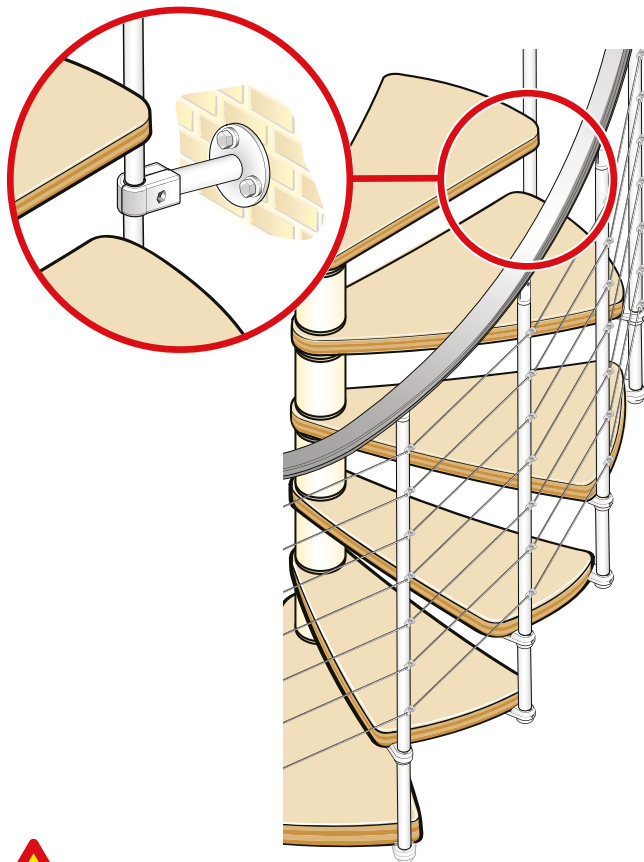

136

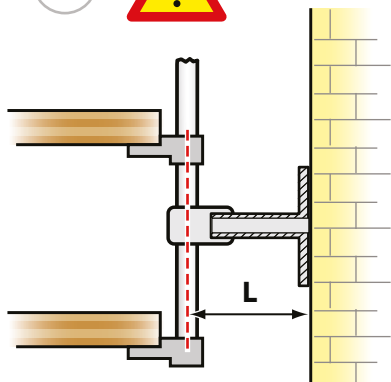

L - 3 cm

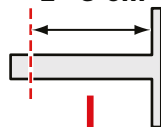

137

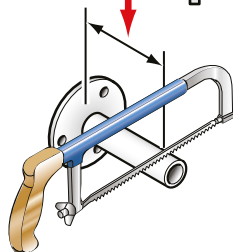



Italiano
English
Deutsch
Français
Español
Português
Nederlands
Polsky
Русский

DATI IDENTIFICATIVI DEL PRODOTTO
PRODUCT IDENTIFICATION DATA
KENN DATEN DES PRODUKTS
DONNÉES D'IDENTIFICATION DU PRODUIT
DATOS DE IDENTIFICACIÓN DEL PRODUCTO
DADOS DE IDENTIFICAÇÃO DO PRODUTO
IDENTIFICATIEGEGEVENS VAN HET PRODUCT
DANE IDENTYFIKACYJNE PRODUKTU
ИДЕНТИФИКАЦИОННЫЕ ДАННЫЕ ТОВАРА



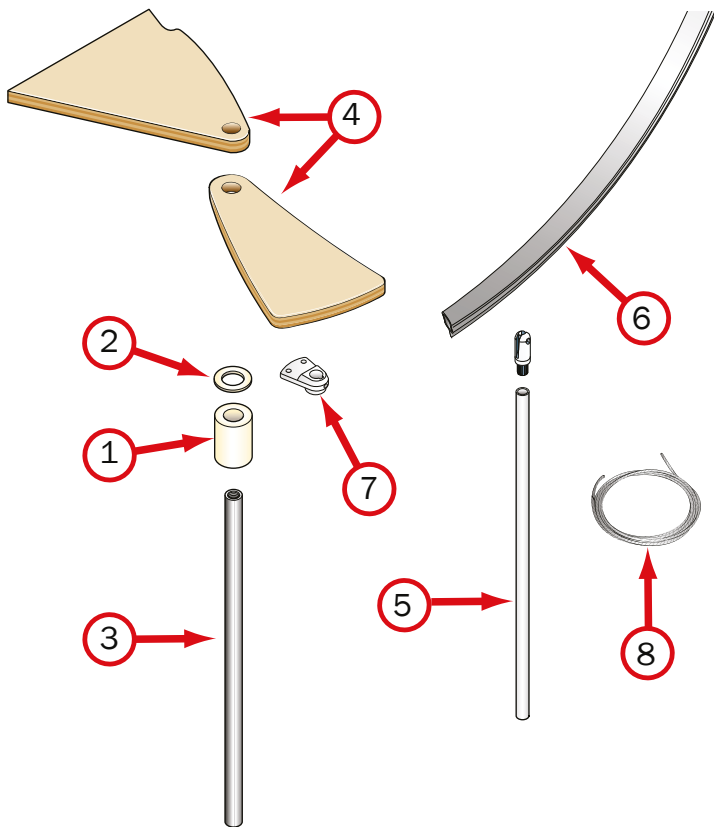

IT)

dati identificativi del prodotto

denominazione commerciale: **NICE LINE**

tipologia: scala a chiocciola a pianta tonda

materiali impiegati

STRUTTURA

descrizione

composta da distanziali (1) in metallo e spessori (2) in plastica impilati e compressi sul palo (3) centrale modulare

materiali

distanziali: Fe 370

spessori: nylon

palo: Fe 370 zincato

finitura

distanziali: verniciatura a forno con polveri epossidiche

GRADINI

descrizione

gradini (4) in legno circolari impilati sul palo (3)

centrale

materiali

multistrato di betulla

RINGHIERA

descrizione

composta da colonnine (5) verticali in metallo fissate ai gradini (4), da cavi in acciaio inox (8) e da un corrimano (6) di PVC

materiali

colonnine: Fe 370

corrimano: PVC

fissaggi (7): nylon

finitura

colonnine: verniciatura a forno con polveri epossidiche

PULIZIA

pulire con panno morbido inumidito in acqua, privo di qualsiasi prodotto contenente solventi o materiali abrasivi.

MANUTENZIONE

dopo circa 12 mesi dalla data di installazione, controllare il serraggio della viteria dei vari componenti. la manutenzione straordinaria deve essere eseguita da personale qualificato. contattare il produttore.

PRECAUZIONI D'USO

evitare usi impropri e non consoni al prodotto. eventuali manomissioni o installazioni non rispondenti alle istruzioni del produttore possono inficiare le conformità prestabilite del prodotto.

EN)

product identification data

trade name: **NICE LINE**

type: spiral round staircase

materials used

STRUCTURE

description

composed of metal spacers (1) and plastic spacer rings (2) stacked and compressed on the modular central pole (3)

materials

spacers: Fe 370

spacers rings: nylon

pole: galvanized Fe 370

finishing

spacers: epoxy powder coated in furnace

TREADS

description

round wooden treads (4) stacked on the central pole

(3)

materials

birch blockboard

RAILING

description

composed of vertical metal balusters (5) fixed to the treads (4), stainless steel cables (8) and a PVC handrail (6)

materials

balusters: Fe 370

handrail: PVC

fixings (7): nylon

finishing

balusters: epoxy powder coated in furnace

CLEANING

clean with a soft cloth moistened in water; do not use any product containing solvents or abrasive materials.

MAINTENANCE

about 12 months after the installation date, check the tightening of bolts on the various components. all non-routine maintenance procedures must be carried out in a strictly professional manner.

USE PRECAUTION

approximately 12 months from the date of installation, check tightness of the screws of the various components. extraordinary maintenance must be carried out by qualified persons. contact the manufacturer.

DE)

Kenndaten des Produkts

Handelsbezeichnung: **NICE LINE**

Typ: runde Spindeltrappe

verwendete Materialien

STRUKTUR

Beschreibung

besteht aus Distanzhülsen **(1)** aus Metall und aufeinander gelegten und an die modulierte Zentralspindel **(3)** angepressten Distanzringen **(2)** aus Kunststoff

Materialien

Distanzhülsen: Fe 370

Distanzringe: Nylon

Spindel: Fe 370 feuerverzinkt

Ausführung

Distanzhülsen: Ofenlackierung mit Epoxydharzpulver

STUFEN

Beschreibung

runde Holzstufen **(4)**, die übereinander auf der Zentralspindel **(3)** liegen

Materialien

Birkenschichtholz

GELÄNDER

Beschreibung

besteht aus vertikalen, auf den Stufen **(4)** befestigten Metallstäben **(5)**, aus Edelstahlkabeln **(8)** und einem Handlauf **(6)** aus PVC

Materialien

Geländerstäbe: Fe 370

Handlauf: PVC

Befestigungsteile **(7)**: Nylon

Ausführung

Geländerstäbe: Ofenlackierung mit Epoxydharzpulver

REINIGUNG

mit einem weichen feuchten Tuch reinigen. keine Reinigungsmittel verwenden, die Lösungs- oder Scheuermittel beinhalten.

WARTUNG

ungefähr 12 Monate nach dem Einbau, die Festigkeit der einzelnen Schrauben überprüfen. eine Sonderwartung muss vom fachkundigen Personal durchgeführt werden. bitte wenden sie sich dafür an den Hersteller.

VORSICHTSMAßNAHMEN FÜR DIE ANWENDUNG

die falsche und unangemessene Verwendung des Produkts vermeiden. eventuelle Beschädigungen oder nicht der Montageanleitung des Herstellers gemässe Einrichtungen können die vorgegebene Produktkonformität für ungültig erklären.

FR)

données d'identification du produit

denomination commerciale: **NICE LINE**

typologie: escalier helicoidal à plan rond

matériaux employés

STRUCTURE

description

composée d'entretoises **(1)** en métal et de disques entretoises **(2)** en plastique empilés et comprimés sur le poteau **(3)** central modulaire

matériaux

entretoises: Fe 370

disques entretoises: nylon

poteau: Fe 370 galvanisé

finition

entretoises: peinture au four avec des poudres d'époxy

MARCHES

description

marches **(4)** en bois circulaires empilées sur le poteau **(3)** central

matériaux

bois lamellaire de bouleau

GARDE-CORPS

description

composé de colonnettes **(5)** verticales en métal fixées aux marches **(4)**, de câbles en acier inox **(8)** et d'une main-courante **(6)** en PVC

matériaux

colonnettes: Fe 370

main-courante: PVC

fixations **(7)**: nylon

finition

colonnettes: peinture au four avec des poudres d'époxy

NETTOYAGE

nettoyer avec un chiffon souplé humidifié à l'eau, sans aucun produit contenant des solvants ou matières abrasives.

ENTRETIEN

après environ 12 mois de la date d'installation, contrôler le serrage de la visserie et des différents éléments. l'entretien extraordinaire doit être exécuté par le personnel qualifié. contacter le producteur.

PRECAUTION D'UTILISATION

éviter l'utilisation impropre et non conforme au produit. d'éventuelles alterations ou installations non correspondantes aux instructions du producteur peuvent invalider les conformités préétablies du produit.

ES)

datos de identificación del producto

denominación comercial: **NICE LINE**

tipología: escalera de caracol de planta redonda

materiales empleados

ESTRUCTURA

descripción

compuesta por distanciadores **(1)** de metal y espaciadores **(2)** de plástico apilados e incluidos en el palo **(3)** central modular

materiales

distanciadores: Fe 370

espaciadores: nylon

palo: Fe 370 cincado

acabado

distanciadores: barnizado al horno con polvos epoxídicos

PELDAÑOS

descripción

peldaños **(4)** de madera circulares apilados en el palo **(3)** central

materiales

madera laminada de abedul

BARANDILLA

descripción

consta de barrotes **(5)** verticales de metal fijados a los peldaños **(4)**, cables de acero inoxidable **(8)** y un pasamanos **(6)** de PVC

materiales

barrotes: Fe 370

pasamanos: PVC

fijaciones **(7)**: nylon

acabado

barrotes: barnizado al horno con polvos epoxídicos

LIMPIEZA

limpie con un paño suave, humedecido en agua, sin productos que contengan disolventes o materiales abrasivos.

MANTENIMIENTO

12 meses después de la fecha de instalación, compruebe el ajuste de los tornillos de los distintos componentes. el mantenimiento extraordinario debe ser realizado por personal cualificado. póngase en contacto con el fabricante.

PRECAUCIONES DE USO

evite usos indebidos y no adecuados para el producto. eventuales manipulaciones o instalaciones que no cumplan con las instrucciones del fabricante pueden menoscabar las cualidades certificadas en las pruebas de conformidad a las que previamente fue sometido el producto.

PT)

dados de identificação do produto

denominação comercial: **NICE LINE**

tipo: escada em caracol de planta redonda

materiais empregados

ESTRUTURA

descrição

composta por distanciadores **(1)** em metal e calços **(2)** de plástico empilhados e comprimidos no poste **(3)** central modular

materiais

distanciadores: Fe 370

calços: nylon

poste: Fe 370 zincado

acabamento

distanciadores: envernizamento em forno com pós epóxi

DEGRAUS

descrição

degraus **(4)** de madeira circulares empilhados no poste **(3)** central

materiais

laminado de bétula

BALAÚSTRE

descrição

composto por colunas **(5)** verticais de metal fixadas aos degraus **(4)**, por cabos de aço inoxidável **(8)** e por um corrimão **(6)** de PVC

materiais

colunas: Fe 370

corrimão: PVC

fixações **(7)**: nylon

acabamento

colunas: envernizamento em forno com pós epóxi

LIMPIEZA

limpar com um pano macio humedecido com água, sem qualquer produto com solventes ou materiais abrasivos.

MANUTENÇÃO

cerca de 12 meses após a data de instalação, verificar que os parafusos e os vários elementos estão bem apertados. a manutenção extraordinária deve ser realizada por pessoal qualificado. contactar o fabricante.

PRECAUÇÕES NO USO

evitar utilizações incorrectas e não adequadas ao produto. eventuais alterações ou instalações que não estiverem de acordo com as instruções do fabricante podem invalidar as características de conformidade predefinidas do produto.

NL)

identificatie van het product

handelsaanduiding: **NICE LINE**

type: ronde spiltrap

gebruikte materialen

CONSTRUCTIE

beschrijving

wordt gevormd door metalen vulstukken (1) en plastic opbouwsegmenten (2) die op elkaar worden gestapeld en samengeperst op de centrale, modulaire paal (3)

materialen

vulstukken: Fe 370

opbouwsegmenten: nylon

paal: Fe 370, verzinkt

afwerking

vulstukken: ovenlak met epoxy-poeders

TREDEN

beschrijving

houten cirkelvormige treden (4) op elkaar gestapeld op centrale paal (3)

materialen

gelamineerd berkenhout

PORTALEN

beschrijving

bestaat uit verticale metalen tussenbalusters (5) die zijn bevestigd aan de treden (4), uit roestvrij stalen kabels (8) en uit een handregel (6) van PVC

materialen

tussenbalusters: Fe 370

handregels: PVC

bevestigingselementen (7): nylon

afwerking

tussenbalusters: ovenlak met epoxy-poeders

SCHOONMAKEN

schoonmaken met een zachte vochtige doek, gebruik geen schoonmaakmiddel dat oplosmiddel of schuurmiddel bevat.

ONDERHOUD

controleer ongeveer 12 maanden na het inbouwen de vastheid van elke schroef; vakbekwaam personeel moet een bijzondere schouw uitvoeren. wendt u a.u.b. zich daarvoor tot de fabrikant.

VOORZORGSMAATREGELEN VOOR HET GEBRUIK

vermijd verkeerd en niet-beoogd gebruik van het product. eventuele schade of een plaatsing, die afwijkt van de aanwijzingen van de fabrikant in de handleiding voor het monteren, kan ertoe leiden dat de vermelde conformiteit van het product ongeldig wordt verklaard.

PL)

dane identyfikacyjne produktu

nazwa handlowa: **NICE LINE**

typologia: schody kręte na planie koła

użyte materiały

STRUKTURA

opis

złożone z metalowych elementów dystansowych (1) oraz plastikowych podkładek regulacyjnych (2) ułożonych i zaciśniętych na centralnym słupku modułowym (3)

materiały

elementy dystansowe: Fe 370

podkładowki regulacyjne: nylon

słupek: Fe 370 ocynkowany

wykończenie

elementy dystansowe: lakierowanie piecowe proszkami epoksydowymi

STOPNIE

opis

drewniane stopnie kręte (4) ułożone na centralnym słupku (3)

materiały

listewki brzożowe

PORĘCZ

opis

składa się z pionowych, metalowych tralek (5) przymocowanych do stopni (4), z lin stalowych ze stali nierdzewnej (8) oraz z pochwytu (6) wykonanego z PVC

materiały

tralki: Fe 370

pochwyty: PVC

elementy mocujące (7): nylon

wykończenie

tralki: lakierowanie piecowe proszkami epoksydowymi

CZYSZCZENIE

czyścić miękką szmatką zamoczoną w wodzie, bez użycia produktów zawierających rozpuszczalniki czy materiały ścierne.

KONSERWACJA

po upływie mniej więcej 12 miesięcy od montażu sprawdzić mocowanie śrub poszczególnych komponentów; wykonanie specjalnych czynności konserwacyjnych należy powierzyć osobom o odpowiednich umiejętnościach; w tym celu należy skontaktować się z producentem.

ZALECENIA DOTYCZĄCE UŻYTKOWANIA

nie dopuszczają do nieprawidłowej eksploatacji w sposób niezgodny z przeznaczeniem produktu. ewentualne modyfikacje lub montaż elementów, których nie ma w instrukcji producenta mogą wpłynąć negatywnie na stabilność produktu.

RU)

идентификационные данные товара

коммерческое название: **NICE LINE**

тип: винтовая лестница с круглым основанием

используемые материалы

КАРКАС

описание

каркас состоит из металлических распорок (1) и пластиковых прокладок (2), которые устанавливаются и сжимаются на центральной модульной опоре (3)

материалы

распорки: Fe 370

прокладки: нейлон

опора: Fe 370, оцинкованная

отделка

распорки: окрашены методом напыления эпоксидным порошком

СТУПЕНИ

описание

круговые деревянные ступени (4), устанавливаемые на центральную опору (3)

материалы

клееная береза

ПЕРИЛА

описание

перила состоят из вертикальных металлических столбиков (5), которые крепятся к ступеням (4), тросов из нержавеющей стали (8) и поручня (6) из ПВХ

материалы

столбики: Fe 370

поручень: ПВХ

крепления (7): нейлон

отделка

столбики: окрашены методом напыления эпоксидным порошком

ЧИСТКА

протирать влажной тряпкой, смоченной в воде. не добавлять в воду моющие средства, содержащие растворители или абразивные вещества.

ТЕХНИЧЕСКОЕ ОБСЛУЖИВАНИЕ

через 12 месяцев со дня установки проверить плотность затяжки винтовых соединений деталей. внеплановый ремонт должен осуществляться только специально подготовленным персоналом. свяжитесь с производителем.

ПРЕДОСТОРОЖНОСТИ ПРИ ЭКСПЛУАТАЦИИ

не допускать ненадлежащего использования, не соответствующего типу изделия. случайные повреждения или монтаж, выполненный не по инструкциям производителя, могут привести к несоответствию продукции установленным требованиям.



N L
D.U.M.
03/2018

nice